

Comprehensive Rust 🦀

Martin Geisler

İçindekiler

Comprehensive Rust'a Hoş Geldiniz 🦀	11
1 Kursun Çalıştırılması	13
1.1 Kurs Yapısı	14
1.2 Klavye Kısayolları	17
1.3 Çeviriler	17
2 Cargo'yu Kullanmak	19
2.1 Rust Ekosistemi	19
2.2 Bu Eğitimdeki Kod Örnekleri	20
2.3 Cargo'nun Yerel (Local) Olarak Çalıştırılması	21
I Gün 1: Sabah	23
3 1. Gün'e Hoş Geldiniz	24
4 Merhaba, Dünya	26
4.1 Rust Nedir?	26
4.2 Rust'ın Faydaları	27
4.3 Deneme Alanı (Playground)	27
5 Türler ve Değerler	29
5.1 Merhaba, Dünya	29
5.2 Değişkenler	30
5.3 Değerler	30
5.4 Aritmetik	31
5.5 Tür Çıkarımı	31
5.6 Alıştırma: Fibonacci	32
5.6.1 Çözüm	33
6 Kontrol Akışı Temelleri	34
6.1 if ifadeleri	34
6.2 Döngüler	35
6.2.1 for	35
6.2.2 loop	36
6.3 break ve continue	36
6.3.1 Etiketler	36
6.4 Bloklar ve Kapsamlar	37

6.4.1	Kapsamlar (Scopes) ve Gölgeleme (Shadowing)	37
6.5	Fonksiyonlar	38
6.6	Makrolar	39
6.7	Alıştırma: Collatz Sekansı	39
6.7.1	Çözüm	41
II	Gün 1: Öğleden Sonra	42
7	Tekrar Hoş Geldiniz	43
8	Demetler (Tuples) ve Diziler (Arrays)	44
8.1	Diziler	44
8.2	Demetler	45
8.3	Dizi Adımlama (Iteration)	45
8.4	Desenler ve Çözümleme (Destructuring)	45
8.5	Alıştırma: İççe Diziler	46
8.5.1	Çözüm	47
9	Referanslar	49
9.1	Paylaşılan Referanslar	49
9.2	Özel (Exclusive) Referanslar	50
9.3	Dilimler (Slices)	51
9.4	Dizeler (Strings)	51
9.5	Alıştırma: Geometri	53
9.5.1	Çözüm	53
10	Kullanıcı Tanımlı Türler	55
10.1	İsimli Yapılar	55
10.2	Demet Yapıları (Tuple Structs)	56
10.3	Enumlar	57
10.4	const	59
10.5	static	59
10.6	Tür Eş İsimleri (Type Aliases)	60
10.7	Alıştırma: Asansör Olayları	60
10.7.1	Çözüm	61
III	Gün 2: Sabah	64
11	Welcome to Day 2	65
12	Desen Eşleştirme	66
12.1	Değerleri Eşleştirmek	66
12.2	Yapılar (Structs)	67
12.3	Enumlar	68
12.4	Let'li Kontrol Akışı	69
12.5	Alıştırma: İfade Değerlendirmesi	71
12.5.1	Çözüm	74
13	Metotlar ve Özellikler (Traits)	77
13.1	Metotlar	77

13.2 Özellikler (Traits)	79
13.2.1 Özelliklerin (Traits) Gerçekleştirimi	79
13.2.2 Üstözellikler (Supertraits)	80
13.2.3 İlişkili Türler	80
13.3 Türetme	81
13.4 Alıştırma: Kaydedici Özellik	81
13.4.1 Çözüm	82
IV Gün 2: Öğleden Sonra	84
14 Tekrar Hoş Geldiniz	85
15 Jenerikler	86
15.1 Jenerik Fonksiyonlar	86
15.2 Jenerik Veri Türleri	87
15.3 Jenerik Özellikler (Traits)	88
15.4 Özellik (Trait) Sınırları	88
15.5 impl Trait	89
15.6 dyn Trait	90
15.7 Alıştırma: Jenerik min	91
15.7.1 Çözüm	92
16 Standart Kütüphane Türleri	93
16.1 Standart Kütüphane	93
16.2 Dokümantasyon	93
16.3 Option	94
16.4 Result	95
16.5 String	95
16.6 Vec	96
16.7 HashMap	97
16.8 Alıştırma: Sayıcı	98
16.8.1 Çözüm	99
17 Standart Kütüphanedeki Özellikler (Traits)	101
17.1 Karşılaştırmalar	101
17.2 Operatörler	102
17.3 From ve Into	103
17.4 Tür Çevirimi	104
17.5 Read ve Write	104
17.6 The Default Trait	105
17.7 Çevreleyiciler (Closures)	106
17.8 Alıştırma: ROT13	107
17.8.1 Çözüm	108
V Gün 3: Sabah	110
18 Welcome to Day 3	111
19 Bellek Yönetimi	112
19.1 Program Belleğinin Gözden Geçirilmesi	112

19.2 Bellek Yönetimine Yaklaşımlar	113
19.3 Sahiplik	114
19.4 Taşıma Semantiği	115
19.5 Clone	117
19.6 Kopyalanan Türler	118
19.7 The Drop Trait	119
19.8 Alıştırma: İnşa Edici / Yapıcı Tür (Builder Type)	120
19.8.1 Çözüm	121
20 Akıllı Göstericiler	124
20.1 Box<T>	124
20.2 Rc	125
20.3 Sahipli Özellik Nesneleri (Owned Trait Objects)	126
20.4 Alıştırma: İkili Ağaç	128
20.4.1 Çözüm	130
VI Gün 3: Öğleden Sonra	133
21 Tekrar Hoş Geldiniz	134
22 Ödünç Alma	135
22.1 Bir Değeri Ödünç Alma	135
22.2 Ödünç Alma Kontrolü	136
22.3 Ödünç Alma Hataları	137
22.4 İç Değişebilirlik (Interior Mutability)	137
22.5 Alıştırma: Sağlık İstatistikleri	139
22.5.1 Çözüm	140
23 Ömürler (Lifetimes)	142
23.1 Ömür için Ek Açıklamalar (Annotations)	142
23.2 Fonksiyon Çağrılarında Ömürler	143
23.3 Veri Yapılarında Ömürler	144
23.4 Alıştırma: Protobuf Ayırıştırma	145
23.4.1 Çözüm	149
VII Gün 4: Sabah	154
24 4. Gün'e Hoş Geldiniz	155
25 Adımlayıcılar (Iterators)	156
25.1 Iterator	156
25.2 IntoIterator	157
25.3 FromIterator	158
25.4 Alıştırma: Adımlayıcı Metot Zincirleme	159
25.4.1 Çözüm	159
26 Modüller	161
26.1 Modüller	161
26.2 Dosya Sistemi Hiyerarşisi	162
26.3 Görünürlük	163

26.4 use, super, self	163
26.5 Alıştırma: Bir GUI Kütüphanesi için Modüller	164
26.5.1 Çözüm	167
27 Test Etme	171
27.1 Birim Testleri	171
27.2 Diğer Test Türleri	172
27.3 Derleyici Tüyleri (Lint) ve Clippy Aracı	173
27.4 Alıştırma: Luhn Algoritması	173
27.4.1 Çözüm	174
VIII Gün 4: Öğleden Sonra	177
28 Tekrar Hoş Geldiniz	178
29 Hata İşleme	179
29.1 Panic'ler	179
29.2 Result	180
29.3 Try Operatörü	181
29.4 Try Dönüşümleri	182
29.5 Dinamik Hata Türleri	183
29.6 thiserror	184
29.7 anyhow	185
29.8 Alıştırma: Result ile Yeniden Yazma	186
29.8.1 Çözüm	188
30 Emniyetsiz (Unsafe) Rust	191
30.1 Emniyetsiz (Unsafe) Rust	191
30.2 Ham Göstericilerinin İçeriği (Dereferencing)	192
30.3 Değişebilir Statik Değişkenler	193
30.4 Birlikler (Unions)	193
30.5 Emniyetsiz Fonksiyonlar	194
30.6 Emniyetsiz Özelliklerin (Unsafe Traits) Gerçekleştirilmesi	195
30.7 Emniyetli FFI Sarıncı (Wrapper)	196
30.7.1 Çözüm	198
IX Android	202
31 Welcome to Rust in Android	203
32 Kurulum (Setup)	204
33 İnşa (Build) Kuralları	205
33.1 Rust Binaries	206
33.2 Rust Libraries	206
34 AIDL	208
34.1 Doğum Günü Servisi Eğitimi	208
34.1.1 AIDL Interfaces	208
34.1.2 Generated Service API	209

34.1.3	Service Implementation	209
34.1.4	AIDL Server	210
34.1.5	Dağıtmak (Deploy)	211
34.1.6	AIDL Client	211
34.1.7	API'yi Değiştirme	213
34.1.8	Updating Client and Service	213
34.2	Working With AIDL Types	214
34.2.1	İlkel (Primitive) Türler	214
34.2.2	Dizi Türleri	214
34.2.3	Nesnelerin Gönderilmesi	215
34.2.4	Parsellenebilir Gönderme	216
34.2.5	Dosyaların Gönderilmesi	217
35	Android'de Test Etme	219
35.1	GoogleTest	220
35.2	Taklit Etme (Mocking)	221
36	Kayıt Tutma (Logging)	223
37	Birlikte Çalışabilirlik	225
37.1	Interoperability with C	225
37.1.1	Using Bindgen	225
37.1.2	Calling Rust	227
37.2	C++ ile	228
37.2.1	Köprü Modülü	229
37.2.2	Rust Bridge Declarations	229
37.2.3	Oluşturulan (Generated) C++	230
37.2.4	C++ Bridge Declarations	230
37.2.5	Paylaşılan (Shared) Türler	231
37.2.6	Paylaşılan (Shared) Enum'lar	232
37.2.7	Rust Hata İşleme	233
37.2.8	C++ Hata İşleme	233
37.2.9	Ek Türler	233
37.2.10	Android'de İnşa Etme (Build)	234
37.2.11	Android'de İnşa Etme (Build)	234
37.2.12	Android'de İnşa Etme (Build)	235
37.3	Interoperability with Java	235
X	Chromium	237
38	Chromium'daki Rust'a Hoş Geldiniz	238
39	Kurulum (Setup)	239
40	Chromium ve Cargo Ekosistemlerinin Karşılaştırılması	241
41	Chromium Rust policy	243
42	İnşa (Build) Kuralları	244
42.1	Including unsafe Rust Code	244
42.2	Chromium C++'dan Rust Koduna Bağımlılık	245

42.3 Visual Studio Code	245
42.4 İnşa (build) kuralları alıştırması	246
43 Test Etme	247
43.1 rust_gtest_interop Kütüphanesi	248
43.2 Rust Testleri için GN Kuralları	248
43.3 chromium::import! Makrosu	248
43.4 Testing exercise	249
44 C++ ile Birlikte Çalışabilirlik	250
44.1 Bağlamalara Örnek	251
44.2 CXX Hata İşleme	252
44.2.1 CXX Error Handling: QR Example	252
44.2.2 CXX Error Handling: PNG Example	253
44.3 Alıştırma: C++ ile Birlikte Çalışabilirlik	254
45 Üçüncü Taraf Kasalarını Ekleme	256
45.1 Configuring the Cargo.toml file to add crates	256
45.2 gnrt_config.toml'yi Yapılandırma	257
45.3 Kasaların İndirilmesi	257
45.4 gn İnşa Kurallarının Oluşturulması	257
45.5 Problemlerin Çözülmesi	258
45.5.1 Kod Oluşturan İnşa Betikleri (Build Scripts)	258
45.5.2 C++ Kodunu İnşa Eden (Build) veya Keyfi Eylemler Gerçekleştiren İnşa Betikleri	259
45.6 Bir Kasaya Bağımlılık	259
45.7 Auditing Third Party Crates	259
45.8 Checking Crates into Chromium Source Code	260
45.9 Kasaları Güncel Tutmak	260
45.10 Alıştırma	260
46 Bringing It Together --- Exercise	262
47 Alıştırma Çözümleri	264
XI Yalın Sistem (Bare Metal): Sabah	265
48 Welcome to Bare Metal Rust	266
49 no_std	268
49.1 A minimal no_std program	269
49.2 alloc	269
50 Mikrodenetleyiciler	271
50.1 Ham MMIO	271
50.2 Peripheral Access Crates	273
50.3 HAL crates	274
50.4 Board support crates	274
50.5 The type state pattern	275
50.6 embedded-hal	276
50.7 probe-rs ve cargo-embed	276

50.7.1 Hata Ayıklama	277
50.8 Other projects	277
51 Alıřtırmalar	279
51.1 Pusula	279
51.2 Bare Metal Rust Morning Exercise	281
XII Yalın Sistem (Bare Metal): Öğleden Sonra	285
52 Application processors	286
52.1 Rust'a Hazırlanmak	286
52.2 Inline assembly	288
52.3 Volatile memory access for MMIO	289
52.4 Let's write a UART driver	289
52.4.1 More traits	291
52.5 A better UART driver	291
52.5.1 Bitflags Kasası	291
52.5.2 Multiple registers	292
52.5.3 Sürücü	293
52.5.4 Using it	294
52.6 Kayıt Tutma (Logging)	295
52.6.1 Using it	296
52.7 İstisnalar	297
52.8 Other projects	298
53 Kullanışlı kasalar (crates)	299
53.1 zerocopy	299
53.2 aarch64-paging	300
53.3 buddy_system_allocator	300
53.4 tinyvec	301
53.5 spin	301
54 Android'de Yalın Sistem (Bare Metal)	303
54.1 vmbase	304
55 Alıřtırmalar	305
55.1 RTC driver	305
55.2 Yalın (Bare) Metal Rust Öğleden Sonra	323
XIII Eşzamanlılık: Sabah	328
56 Welcome to Concurrency in Rust	329
57 İş Parçacıkları (Threads)	330
57.1 Temel İş Parçacıkları (Plain Threads)	330
57.2 Kapsamlı İş Parçacıkları (Threads)	331
58 Kanallar	333
58.1 Vericiler ve Alıcılar	333
58.2 Sınırsız Kanallar	334

58.3 Sınırlı Kanallar	334
59 Send ve Sync	336
59.1 Marker Özellikleri (Traits)	336
59.2 Send	336
59.3 Sync	337
59.4 Örnekler	337
60 Paylaşımlı Durum (State)	339
60.1 Arc	339
60.2 Mutex	340
60.3 Örnek	340
61 Alıştırmalar	342
61.1 Filozofların Akşam Yemeği	342
61.2 Çok İş Parçacıklı Link Denetleyicisi	343
61.3 Çözümler	345
XIV Eşzamanlılık: Öğleden Sonra	351
62 Hoş Geldiniz	352
63 Async Temelleri	353
63.1 async/await	353
63.2 Future Özellikleri (Traits)	354
63.3 Çalışma Zamanları	354
63.3.1 Tokio Kasası	355
63.4 Görevler	356
64 Kanallar ve Kontrol Akışı	357
64.1 Async Kanalları	357
64.2 Join	358
64.3 Select	359
65 Tuzaklar	360
65.1 Blocking the executor	360
65.2 Pin	361
65.3 Async Özellikleri (Traits)	363
65.4 İptal (Cancellation)	364
66 Alıştırmalar	367
66.1 Filozofların Akşam Yemeği --- Async	367
66.2 Yayınlanmalı Sohbet Uygulaması	368
66.3 Çözümler	371
XV Son sözler	375
67 Teşekkürler!	376
68 Sözlük	377

69 Other Rust Resources	381
70 Emekler	383

Comprehensive Rust'a Hoş Geldiniz

build passing contributors 303 stars 28k

Bu, Google'daki Android ekibi tarafından geliştirilen ücretsiz bir Rust kursudur. Kurs, temel sözdiziminden jenerikler ve hata işleme gibi ileri düzey konulara kadar Rust'ın tüm yelpazesini kapsar.

Kursun en son sürümüne <https://google.github.io/comprehensive-rust/> adresinden ulaşılabilir. Başka bir yerde okuyorsanız, lütfen güncellemeleri kontrol edin.

Kurs diğer dillerde de mevcuttur. Sayfanın sağ üst köşesinden tercih ettiğiniz dili seçin veya tüm mevcut çevirilerin listesi için [Çeviriler](#) sayfasını kontrol edin.

Kurs ayrıca **PDF olarak** da mevcuttur.

Kursun amacı size Rust'ı öğretmektir. Rust hakkında hiçbir şey bilmediğinizi varsayıyoruz ve şunu umuyoruz:

- Rust sözdizimi ve dili hakkında kapsamlı bir anlayış sunmayı.
- Rust'ta mevcut programları değiştirmenize ve yeni programlar yazmanıza olanak sağlamayı.
- Yaygın Rust kod kaplarını göstermeyi.

İlk dört kurs gününe Rust Esasları (Rust Fundamentals) adını veriyoruz.

Buna dayanarak, bir veya daha fazla uzmanlık konusuna dalmaya davetlisiniz:

- **Android:** Android platformu geliştirme (AOSP) için Rust'ın kullanımına ilişkin yarım günlük bir kurs. Buna C, C++ ve Java ile birlikte çalışabilirlik de dahildir.
- **Chromium:** Rust'ın Chromium tabanlı tarayıcılarda kullanılmasına ilişkin yarım günlük bir kurs. Bu, C++ ile birlikte çalışabilirliği ve üçüncü taraf kasaların Chromium'a nasıl dahil edileceğini içerir.
- **Yalın-metal:** Yalın sistem (gömülü) geliştirme için Rust'ın kullanımına ilişkin tam günlük bir ders. Hem mikrodenetleyiciler hem de uygulama işlemcileri kapsamaktadır.
- **Eşzamanlılık:** Rust'ta eşzamanlılık üzerine tam günlük bir ders. Hem klasik eşzamanlılığı (iş parçacıkları ve muteksleri kullanarak kesintili/geçişli zamanlama) hem de async/await eşzamanlılığını (future özelliklerini kullanarak işbirlikçi çoklu görev) ele alıyoruz.

Hedef Dışı

Rust geniş bir dil ve birkaç gün içinde tamamını ele almamız mümkün olmayacak. Aşağıdakiler bu kursun amaçları dışında kalır:

- Makroların nasıl geliştirileceğini öğrenmek: lütfen bunun yerine [Rust Book'ta Bölüm 19.5](#) ve [Örneklerle Rust](#) bakınız.

Varsayımlar

Kurs, nasıl programlanacağını zaten bildiğinizi varsayar. Rust, statik olarak türlenen bir dildir ve Rust yaklaşımını daha iyi açıklamak veya karşılaştırmak için bazen C ve C++ ile karşılaştırmalar yapacağız.

Python veya JavaScript gibi dinamik olarak yazılmış bir dilde nasıl programlanacağını biliyorsanız, o zaman da gayet iyi takip edebileceksiniz.

Bu bir *konuşmacı notu* örneğidir. Bunları slaytlara ek bilgi eklemek için kullanacağız. Bunlar, eğitmenin ele alması gereken önemli noktaların yanı sıra sınıfta ortaya çıkan tipik soruların yanıtları da olabilir.

Bölüm 1

Kursun Çalıştırılması

Bu sayfa kurs eğitmenine yöneliktir.

Kursu Google'da dahili olarak nasıl kullandığımıza dair biraz arka plan bilgisini burada bulabilirsiniz.

Dersleri genellikle sabah 9:00'dan akşam 16:00'ya kadar yürütüyoruz ve ortasında 1 saatlik öğle yemeği arası veriyoruz. Geriye sabah dersi için 3saat, öğleden sonra dersi için ise 3 saat kalıyor. Her iki oturum da öğrencilerin alıştırmalar üzerinde çalışmalarını için birden fazla ara ve zaman içerir.

Kursu çalıştırmadan önce şunları yapmak isteyeceksiniz:

1. Ders materyaline aşına olun. Önemli noktaların vurgulanmasına yardımcı olmak için konuşmacı notları ekledik (lütfen daha fazla konuşmacı notuna katkıda bulunarak bize yardımcı olun!). Sunum yaparken, konuşmacı notlarını açılır pencerede açtığınızdan emin olmalısınız ("Konuşmacı Notları"nın yanındaki küçük oklu bağlantıya tıklayın). Bu şekilde sınıfa sunacağınız temiz bir ekrana sahip olursunuz.
2. Tarihlerle karar verin. Kurs en az dört tam gün sürdüğünden, günleri iki haftaya yaymanızı öneririz. Kurs katılımcıları, kursta boşluk kalmasının, onlara verdiğimiz tüm bilgileri işlemelerine yardımcı olması açısından yararlı bulduklarını belirtmişlerdir.
3. Katılımcılarınız için yeterince büyük bir oda bulun. Sınıf mevcudununun 15-25 kişilik olmasını öneriyoruz. Bu, insanların rahatça soru sorabileceği kadar küçüktür --- aynı zamanda bir eğitmenin soruları yanıtlamak için zamanının olacağı kadar da küçüktür. Odada kendiniz ve öğrencileriniz için *masaların* olduğundan emin olun: hepinizin oturup dizüstü bilgisayarlarınızla çalışabilmesi gerekir. Özellikle eğitmen olarak çok sayıda canlı kodlama yapacaksınız, bu nedenle kürsü size pek yardımcı olmayacaktır.
4. Kurs gününüzde, işleri ayarlamak için odaya biraz erken gelin. Doğrudan dizüstü bilgisayarınızda çalışan mdbook serve komutunu kullanarak sunum yapmanızı öneririz (**kurulum talimatlarına** bakın). Bu, sayfaları değiştirirken gecikme olmadan en iyi performansı sağlar. Dizüstü bilgisayarınızı kullanmak, siz veya kurs katılımcılarının tespit ettiği yazım hatalarını düzeltmenize de olanak tanır.
5. İnsanların alıştırmaları kendi başlarına veya küçük gruplar halinde çözmelerine izin verin. Genellikle sabah ve öğleden sonra alıştırmalara 30-45 dakika harcıyoruz (çözümleri gözden geçirme (review) zamanı da dahil). İnsanlara takılıp kalmadıklarını

veya yardımcı olabileceğiniz bir konu olup olmadığını sorduğunuzdan emin olun. Birkaç kişinin aynı sorunu yaşadığını gördüğünüzde bunu sınıfa söyleyin ve bir çözüm önerin; örneğin insanlara standart kütüphanede ilgili bilgiyi nerede bulabileceklerini gösterin.

Hepsi bu kadar, kursta iyi şanslar! Umarız bizim için olduğu kadar sizin için de eğlenceli olur!

Kursu geliştirmeye devam edebilmemiz için lütfen sonrasında **geri bildirimde bulunun**. Sizin için neyin işe yaradığını ve neyin daha iyi hale getirilebileceğini duymak isteriz. Öğrencileriniz de **bize geri bildirim gönderebilir!**

1.1 Kurs Yapısı

Bu sayfa kurs eğitmenine yöneliktir.

Rust Esasları

İlk dört gün **Rust Temelleri**'ni oluşturur. Günler hızlı geçiyor ve çok fazla yol kat ediyoruz!

Kurs programı:

- 1. Gün Sabah (2 saat 5 dakika, aralar dahil)

Bölüm	Süre
Hoş Geldiniz	5 dakika
Merhaba, Dünya	15 dakika
Türler ve Değerler	40 dakika
Kontrol Akışı Temelleri	40 dakika

- 1. Gün Öğleden Sonra (2 saat 35 dakika, aralar dahil)

Bölüm	Süre
Demetler (Tuples) ve Diziler (Arrays)	35 dakika
Referanslar	55 dakika
Kullanıcı Tanımlı Türler	50 dakika

- 2. Gün Sabah (2 saat 10 dakika, aralar dahil)

Bölüm	Süre
Hoş Geldiniz	3 dakika
Desen Eşleştirme	1 saat
Metotlar ve Özellikler (Traits)	50 dakika

- 2. Gün Öğleden Sonra (3 saat 15 dakika, aralar dahil)

Bölüm	Süre
Jenerikler	45 dakika
Standart Kütüphane Türleri	1 saat
Standart Kütüphanedeki Özellikler (Traits)	1 saat 10 dakika

- 3. Gün Sabah (2 saat 20 dakika, aralar dahil)

Bölüm	Süre
Hoş Geldiniz	3 dakika
Bellek Yönetimi	1 saat
Akıllı Göstericiler	55 dakika

- 3. Gün Öğleden Sonra (1 saat 55 dakika, aralar dahil)

Bölüm	Süre
Ödünç Alma	55 dakika
Ömürler (Lifetimes)	50 dakika

- 4. Gün Sabah (2 saat 40 dakika, aralar dahil)

Bölüm	Süre
Hoş Geldiniz	3 dakika
Adımlayıcılar (Iterators)	45 dakika
Modüller	40 dakika
Test Etme	45 dakika

- 4. Gün Öğleden Sonra (2 saat 20 dakika, aralar dahil)

Bölüm	Süre
Hata İşleme	1 saat 5 dakika
Emniyetsiz (Unsafe) Rust	1 saat 5 dakika

Derin Dalışlar

Rust'ın Esasları hakkındaki 4 günlük derse ek olarak, daha özel konuları da ele alıyoruz:

Android'de Rust

[Rust in Android](#) ayrıntılı incelemesi, Android platformu geliştirme için Rust'ı kullanma konusunda yarım günlük bir kurstur. Buna C, C++ ve Java ile birlikte çalışabilirlik (interoperability) de dahildir.

Bir [AOSP kasa](#)sına ihtiyacınız olacak. Aynı makinede [kurs deposunu](#) kontrol edin ve `src/android/` dizinini AOSP kasa'nın kök dizinine taşıyın. Bu, Android inşa (build) sisteminin `src/android/` içindeki `Android.bp` dosyalarını görmesini sağlayacaktır.

adb sync emülatörünüzle veya gerçek cihazınızla çalıştığından emin olun ve tüm Android örneklerini `src/android/build_all.sh` kullanarak önceden inşa (build) edin. Çalıştırdığı komutları görmek için betiği okuyun ve bunları elle çalıştırdığınızda çalışıklarından emin olun.

Chromium'da Rust

[Chromium'da Rust](#)'ın ayrıntılı incelemesi, Rust'ın Chromium tarayıcısının bir parçası olarak kullanılmasına ilişkin yarım günlük bir kurstur. Bu, Chromium'un gn yapı sisteminde Rust'ın kullanılmasını, üçüncü taraf kitaplıkların ("kasalar/crates") getirilmesini ve C++ ile birlikte çalışabilirliğini içerir.

You will need to be able to build Chromium --- a debug, component build is [recommended](#) for speed but any build will work. Ensure that you can run the Chromium browser that you've built.

Yalın-Sistem (Bare-metal) Rust

[Yalın-Sistem Rust](#) ayrıntılı incelemesi, yalın sistem (gömülü) geliştirme için Rust kullanımına ilişkin tam günlük bir derstir. Hem mikrodenetleyiciler hem de uygulama işlemcileri kapsamaktadır.

Mikrodenetleyici kısmı için [BBC micro:bit v2](#) geliştirme kartını önceden satın almanız gerekecek. Herkesin [karşılama sayfasında](#) açıklandığı gibi bir dizi paketi yüklemesi gerekecektir.

Rust'ta Eşzamanlılık

[Rust'ta Eşzamanlılık](#) ayrıntılı incelemesi, klasik ve aynı zamanda `async/await` eşzamanlılığı üzerine tam günlük bir derstir.

Yeni bir kasa (crate) kurulumuna ve bağımlılıkların indirilip kullanıma hazır hale getirilmesine ihtiyacınız olacak. Daha sonra örnekleri denemek için kopyalayıp `src/main.rs` dosyasına yapıştırabilirsiniz:

```
cargo init concurrency
cd concurrency
cargo add tokio --features full
cargo run
```

Kurs programı:

- Sabah (3 saat 20 dakika, aralar dahil)

Bölüm	Süre
İş Parçacıkları (Threads)	30 dakika
Kanallar	20 dakika
Send ve Sync	15 dakika
Paylaşımli Durum (State)	30 dakika
Alıştırmalar	1 saat 10 dakika

- Öğleden Sonra (3 saat 20 dakika, aralar dahil)

Bölüm	Süre
Async Temelleri	30 dakika
Kanallar ve Kontrol Akışı	20 dakika
Tuzaklar	55 dakika
Alıştırmalar	1 saat 10 dakika

Format

Kursun çok etkileşimli olması amaçlanıyor ve soruların Rust'ın keşfini yönlendirmesine izin vermenizi öneririz!

1.2 Klavye Kısayolları

Bu mdBook'ta birkaç kullanışlı klavye kısayolu vardır:

- Arrow-Left
: Önceki sayfaya gidin.
- Arrow-Right
: Sonraki sayfaya gidin.
- Ctrl + Enter
: Odaklı kod örneğini yürütün.
- s
: Arama çubuğunu etkinleştirin.

1.3 Çeviriler

Kurs bir grup harika gönüllüler tarafından diğer dillere çevrildi:

- **Brezilya Portekizcesi** yazarlar: [@rastringer](#), [@hugojacob](#), [@joaovicmendes](#) ve [@henrif75](#).
- **Çince (Basitleştirilmiş)** yazarlar: [@suetfei](#), [@wnghl](#), [@anlunx](#), [@kongy](#), [@noahdragon](#), [@superwhd](#), [@SketchK](#) ve [@nodmp](#).
- **Çince (Geleneksel)** yazarlar: [@hueich](#), [@victorhsieh](#), [@mingyc](#), [@kuanhungchen](#) ve [@johnathan79717](#).
- **Farsça** yazarlar: [@DannyRavi](#), [@javad-jafari](#), [@Alix1383](#), [@moaminsharifi](#), [@hamidrezakp](#) ve [@mehrads77](#).
- **Japonca** yazarlar: [@CoinEZ-JPN](#), [@momotaro1105.com/momotaro1105](#)), [@HidenoriKobayashi](#) ve [@kantasv](#).
- **Korece** yazarlar: [@keispace](#), [@jiyongp](#) (/jiyongp), [@jooyunghan](#) ve [@namhyung](#).
- **Bengalce** yazarlar: [@raselmandol](#).
- **Ukraynaca** yazarlar: [@git-user-cpp](#), [@yaremam](#) ve [@reta](#).
- **Farsça** yazarlar: [@DannyRavi](#), [@javad-jafari](#), [@Alix1383](#), [@moaminsharifi](#), [@hamidrezakp](#) ve [@mehrads77](#).

Diller arasında geçiş yapmak için sağ üst köşedeki dil seçiciyi kullanın.

Tamamlanmamış Çeviriler

Devam eden çok sayıda çeviri var. En son güncellenen çevirilere bağlantı veriyoruz:

- Arapça yazarlar: @younies
- Bengalce yazarlar: @raselmandol.
- Fransızca yazarlar: @KookaS, @vcaen /vcaen) ve @AdrienBaudemont.
- Almanca yazarlar: @Throvn ve @ronaldfw /ronaldfw).
- İtalyanca yazarlar: @henrythebuilder ve @detro.

Çevirilerin tam listesi ve güncel durumları **son güncelleme tarihi itibarıyla** veya **kursun en son sürümüyle senkronize edilmiş olarak** da mevcuttur.

Bu çabaya yardımcı olmak istiyorsanız nasıl başlayacağınızı öğrenmek için lütfen **talimatlarımıza** bakın. Çeviriler **sorun izleyicide** üzerinde koordine edilir.

Bölüm 2

Cargo'yu Kullanmak

Rust hakkında okumaya başladığınızda, Rust ekosisteminde Rust uygulamalarını inşa etmek (build) ve çalıştırmak için kullanılan standart araç **Cargo** ile yakında tanışacaksınız. Burada Cargo'nun ne olduğuna, daha geniş ekosisteme nasıl uyum sağladığına ve bu eğitime nasıl uyduğuna dair kısa bir genel bakış sunmak istiyoruz.

Kurulum

Lütfen <https://rustup.rs/> adresindeki talimatları izleyin.

Bu size Cargo oluşturma aracını (cargo) ve Rust derleyicisini (rustc) sağlayacaktır. Ayrıca, araç zincirlerini (toolchain) kurmak/değiřtirmek, çapraz derlemeyi ayarlamak vb. için kullanabileceğiniz bir komut satırı yardımcı programı olan rustup a sahip olacaksınız.

Rust'u kurduktan sonra editörünüzü/düzenleyicinizi veya IDE'nizi Rust ile çalışacak şekilde yapılandırmanız gerekir. Çoğu editör bunu, **VS Code**, **Emacs**, [Vim/Neovim](<https://rust-analyzer.github.io/manual.html#vimneovim>) ve diğersleri için otomatik tamamlama ve tanıma atlama işlevi sağlayan **rust-analyzer** ile haberleşerek yapar. Ayrıca **RustRover** adında farklı bir IDE de mevcuttur.

- Debian/Ubuntu'da ayrıca apt aracılığıyla Cargo'yu, Rust kaynak kodunu ve **Rust biçimlendiricisini** kurabilirsiniz. Ancak bu size eski bir Rust sürümü verir ve beklenmeyen davranışlara yol açabilir. Komut şu şekilde olacaktır:

```
sudo apt install cargo rust-src rustfmt
```

- Mac işletim sisteminde Rust'ı yüklemek için **Homebrew**'i kullanabilirsiniz, ancak bu eski bir sürüm sağlayabilir. Bu nedenle Rust'ı resmi sitesinden kurmanız önerilir.

2.1 Rust Ekosistemi

Rust ekosistemi bir dizi araçtan oluşur; bunların başlıcaları şunlardır:

- rustc: .rs dosyalarını ikili (binary) dosyalara ve diğers ara biçimlere (format) dönüřtüren Rust derleyicisi.

- cargo: Rust bağımlılık yöneticisi ve inşa (build) aracı. Cargo, genellikle <https://crates.io> üzerinde barındırılan bağımlılıkları nasıl indireceğini bilir ve projenizi oluştururken bunları rustc derleyicisine aktarır. Cargo ayrıca birim testlerini yürütmek için kullanılan yerleşik bir test çalıştırıcısıyla birlikte gelir.
- rustup: Rust araç zinciri (toolchain) yükleyicisi ve güncelleyicisi. Bu araç, Rust'ın yeni sürümleri yayınlandığında rustc ve cargo programlarını yüklemek ve güncellemek için kullanılır. Ek olarak, rustup standart kitaplık için belgeleri de indirebilir. Aynı anda birden fazla Rust sürümünü yükleyebilirsiniz ve rustup gerektiğinde bunlar arasında geçiş yapmanıza olanak tanır.

Anahtar noktalar:

- Rust'un her altı haftada bir yeni sürümünün çıktığı hızlı bir sürüm programı var. Yeni sürümler, eski sürümlerle geriye dönük uyumluluğu korur ve ayrıca yeni işlevsellik sağlar.
- Üç sürüm kanalı vardır: "kararlı (stable)", "beta" ve "gecelik (nightly)".
- Yeni özellikler "gecelik (nightly)" kanalında test ediliyor, "beta" her altı haftada bir "kararlı (stable)" hale geliyor.
- Bağımlılıklar ayrıca alternatif olarak [kayitlardan](#), git'ten, klasörlerden ve daha fazlasından çözülebilir.
- Rust'ın ayrıca [yayınları](#) (editions) vardır: mevcut yayın (edition) Rust 2021'dir. Önceki yayınlar Rust 2015 ve Rust 2018'di.
 - Yayınların dilde geriye dönük olarak uyumsuz değişiklikler yapmasına izin verilir.
 - Kodun kırılmasını (breaking code) önlemek için yayınlar isteğe bağlıdır: Cargo.toml dosyası aracılığıyla kasanızın (crate) sürümünü seçersiniz.
 - Ekosistemin bölünmesini önlemek için Rust derleyicileri farklı sürümler için yazılan kodları karıştırabilir.
 - Derleyiciyi cargo yoluyla değil de doğrudan kullanmanın oldukça nadir olduğunu unutmayın (çoğu kullanıcı asla kullanmaz).
 - Cargo'nun kendisinin son derece güçlü ve kapsamlı bir araç olduğunu belirtmekte fayda var. Aşağıdakiler dahil olmakla ve bunlarla sınırlı olmamak üzere birçok gelişmiş özelliğe sahiptir:
 - * Proje/paket yapısı
 - * [çalışma alanları](#)
 - * Geliştirici Bağımlılıkları ve Çalışma Zamanı Bağımlılığı yönetimi/önbelleğe alma
 - * [build scripting](#)
 - * [genel kurulum](#)
 - * Ayrıca alt komut eklentileriyle de genişletilebilir ([cargo Clippy](#) gibi).
 - [Resmi Cargo Kitabı'ndan](#) daha fazlasını okuyun

2.2 Bu Eğitimdeki Kod Örnekleri

Bu eğitimde çoğunlukla Rust dilini tarayıcınız üzerinden yürütebileceğiniz örnekler üzerinden inceleyeceğiz. Bu, kurulumu çok daha kolay hale getirir ve herkes için tutarlı bir

deneyim sağlar.

Cargo'nun kurulumu hala teşvik edilmektedir: alıştırmaları yapmanızı kolaylaştıracaktır. Son gün, bağımlılıklarla nasıl çalışacağınızı ve bunun için Cargo'ya ihtiyacınız olduğunu gösteren daha büyük bir alıştırma yapacağız.

Bu kurstaki kod blokları tamamen etkileşimlidir:

```
fn main() {  
    println!("Düzenle beni!");  
}
```

Metin kutusu odaklanmışken kodu çalıştırmak için

Ctrl + Enter

tuşlarını kullanabilirsiniz.

Çoğu kod örneği yukarıda gösterildiği gibi düzenlenebilir. Birkaç kod örneği çeşitli nedenlerden dolayı düzenlenemez:

- Gömülü deneme alanları (playgrounds) birim testlerini yürütemez. Birim testlerini göstermek için kodu kopyalayıp yapıştırın ve gerçek Deneme Alanında (Playground) açın.
- Gömülü deneme alanları, sayfadan uzaklaştığınız anda durumlarını kaybeder! Öğrencilerin alıştırmaları yerel bir Rust kurulumu kullanarak veya Deneme Alanı aracılığıyla çözmelerinin nedeni budur.

2.3 Cargo'nun Yerel (Local) Olarak Çalıştırılması

Kodu kendi sisteminizde denemek istiyorsanız, önce Rust'u yüklemeniz gerekecektir. Bunu [Rust Book'taki talimatları](#) uygulayarak yapın. Bu size çalışan bir rustc ve cargovermelidir. Bu yazının yazıldığı sırada en son kararlı Rust sürümü şu sürüm numaralarına sahiptir:

```
% rustc --version  
rustc 1.69.0 (84c898d65 2023-04-16)  
% cargo --version  
cargo 1.69.0 (6e9a83356 2023-04-12)
```

Rust geriye dönük uyumluluğu koruduğu için daha sonraki herhangi bir sürümü de kullanabilirsiniz.

Bunu yaptıktan sonra, bu eğitimdeki örneklerden birinden bir Rust ikili (binary) programı oluşturmak için şu adımları izleyin:

1. Kopyalamak istediğiniz örneğin üzerindeki "Panoya kopyala" düğmesine tıklayın.
2. Kodunuz için yeni bir exercise/ dizini oluşturmak için cargo new exercise komutunu kullanın:

```
$ cargo new exercise  
Created binary (application) `exercise` package
```
3. İkili (binary) dosyanızı inşa etmek (build) ve çalıştırmak için exercise/ dizinine gidin ve cargo run komutunu kullanın:

```
$ cd exercise
$ cargo run
  Compiling exercise v0.1.0 (/home/mgeisler/tmp/exercise)
  Finished dev [unoptimized + debuginfo] target(s) in 0.75s
  Running `target/debug/exercise`
Hello, world!
```

4. `src/main.rs` dosyasındaki hazır kodu kendi kodunuzla değiştirin. Örneğin, önceki sayfadaki örneği kullanarak `src/main.rs` dosyasının şu şekilde görünmesini sağlayın

```
fn main() {
    println!("Düzenle beni!");
}
```

5. Güncellenmiş ikili (binary) dosyanızı inşa etmek (build) ve çalıştırmak (run) için cargo run komutunu kullanın:

```
$ cargo run
  Compiling exercise v0.1.0 (/home/mgeisler/tmp/exercise)
  Finished dev [unoptimized + debuginfo] target(s) in 0.24s
  Running `target/debug/exercise`
Edit me!
```

6. Projenizi hatalara karşı hızlı bir şekilde kontrol etmek için cargo check komutunu kullanın, çalıştırmadan derlemek için cargo build komutunu kullanın. Normal bir hata ayıklama inşasında (build) çıktıyı `target/debug/` içinde bulacaksınız. `target/release/` içinde optimize edilmiş bir sürüm inşası oluşturmak için cargo build --release komutunu kullanın.
7. Cargo.toml dosyasını düzenleyerek projeniz için bağımlılıklar ekleyebilirsiniz. cargo komutlarını çalıştırdığınızda, eksik bağımlılıkları sizin için otomatik olarak indirip derleyecektir.

Sınıf katılımcılarını Cargo'yu yüklemeye ve yerel bir metin düzenleyici kullanmaya teşvik etmeye çalışın. Normal bir gelişim ortamına sahip olacakları için hayatları kolaylaşacaktır.

Kısım I

Gün 1: Sabah

Bölüm 3

1. Gün'e Hoş Geldiniz

Rust Esasları'nın ilk günü. Bugün çok fazla konuyu ele alacağız:

- Temel Rust sözdizimi: değişkenler, skaler ve bileşik türleri, numaralandırma türleri (enums), yapılar (structs), referanslar, fonksiyonlar ve metotlar.
- Türler ve tür çıkarımı.
- Kontrol akışı yapıları (constructs): döngüler, koşullar vb.
- Kullanıcı tanımlı türler: yapılar (structs) ve numaralandırmalar (enums)
- Desen eşleştirme: numaralandırmaların (enums), yapıların ve dizilerin çözümlenmesi (destructuring).

Zamanlama (Schedule)

Bu oturum 10 dakikalık aralar dahil yaklaşık 2 saat 5 dakika sürmelidir. İçeriği:

Bölüm	Süre
Hoş Geldiniz	5 dakika
Merhaba, Dünya	15 dakika
Türler ve Değerler	40 dakika
Kontrol Akışı Temelleri	40 dakika

Lütfen öğrencilere şunu hatırlatın:

- Sorular akıllarına geldiğinde sormalılar, sona saklamamalılar.
- Sınıfın etkileşimli olması amaçlanıyor ve tartışmalar çok teşvik ediliyor!
 - Bir eğitmen olarak tartışmaları güncel tutmaya çalışmalısınız, yani Rust'ın işi nasıl yaptığı ve başka bir dilin işi nasıl yaptığıyla ilgili tartışmaları sürdürün. Doğru dengeyi bulmak zor olabilir, ancak insanları tek yönlü iletişimden çok daha fazla meşgul ettiği için tartışmalara izin vermeyi tercih edin.
- Sorular çoğunlukla slaytlardan önce bazı şeyler hakkında konuşacağımız anlamına gelecektir.
 - Bu kesinlikle sorun değil! Tekrar etmek, öğrenmenin önemli bir parçasıdır. Slaytların sadece bir destek olduğunu ve istediğiniz gibi atlamakta özgür olduğunuzu unutmayın.

İlk günün amacı, Rust'ta diğer dillerle hemen hemen paralel olması gereken "temel" şeyleri göstermektir. Rust'ın daha gelişmiş kısımları ilerleyen günlerde gelecek.

Eğer bunu bir sınıfta öğretiyorsanız, burası programın üzerinden geçmek için iyi bir yerdir. Her bölümün sonunda bir alıştırma ve ardından bir ara olduğunu unutmayın. Aradan sonra alıştırma çözümünü tamamlamayı planlayın. Burada listelenen zamanlar kursun programa uygun devam etmesi için bir öneridir. Esnek olmaktan ve gerektiği gibi ayarlamaktan çekinmeyin!

Bölüm 4

Merhaba, Dünya

Bu bölüm yaklaşık 15 dakika sürmelidir. İçeriği:

Slayt	Süre
Rust Nedir?	10 dakika
Rust'ın Faydaları	3 dakika
Deneme Alanı (Playground)	2 dakika

4.1 Rust Nedir?

Rust, **2015'te 1.0 sürümü** çıkan yeni bir programlama dilidir:

- Rust, C++ ile benzer role sahip statik olarak derlenmiş bir dildir
 - rustc arka tarafta (backend) LLVM'yi kullanır.
- Rust birçok **platformu ve mimariyi** destekler:
 - x86, ARM, WebAssembly, ...
 - Linux, Mac, Windows, ...
- Rust çok çeşitli cihazlarda kullanılır:
 - donanım yazılımlarında (firmwares) ve önyükleyicilerde (boot loaders),
 - akıllı ekranlarda,
 - cep telefonlarında,
 - masaüstü bilgisayarlarda,
 - sunucularda.

Rust, C++ ile aynı alanda yer almaktadır:

- Yüksek esneklik.
- Yüksek düzeyde kontrol.
- Mikrodenetleyiciler gibi çok kısıtlı cihazlara ölçeklendirilebilir.
- Çalışma zamanı veya çöp toplama özelliği yoktur.
- Performanstan ödün vermeden güvenilirlik ve emniyete (safety) odaklanır.

4.2 Rust'ın Faydaları

Rust'ın bazı benzersiz yok satan noktaları:

- *Derleme zamanı bellek emniyeti* - derleme zamanında tüm bellek hataları sınıfları önlenir
 - İklendirilmemiş değişken yok.
 - Adresi iki kez serbest bırakma (double free) yok.
 - Serbest bıraktıktan sonra kullanma (use after free) yok.
 - NULL göstericileri yok.
 - Unutulan kilitli muteksler yok.
 - İş parçacıkları (threads) arasında veri yarışları (data races) yok.
 - Adımlayıcıyı (iterator) geçersiz kılma (invalidation) yok.
- *Tanımsız çalışma zamanı davranışı yok* - Bir Rust deyiminin yaptığı şey hiçbir zaman belirtilmemiş (unspecified) olarak bırakılmaz
 - Dizi erişiminde sınırlar kontrol edilir.
 - Tamsayı taşması tanımlandı (panic veya wrap-around).
- *Modern dil özellikleri* - üst seviye diller kadar etkileyici ve ergonomik
 - Numaralandırmalar (Enums) ve desen eşleştirme.
 - Jenerikler.
 - FFI ek yükü yok.
 - Sıfır maliyetli soyutlamalar.
 - Mükemmel derleyici hata mesajları.
 - Yerleşik bağımlılık yöneticisi.
 - Test için yerleşik destek.
 - Mükemmel Dil Sunucusu Protokolü (Language Server Protocol) desteği.

Burada fazla zaman geçirmeyin. Bu noktaların tümü ileride daha derinlemesine ele alınacaktır.

Sınıfa hangi dillerde deneyime sahip olduklarını mutlaka sorun. Cevabınıza bağlı olarak Rust'ın farklı özelliklerini vurgulayabilirsiniz:

- C veya C++ deneyimi: Rust, ödünç alma denetleyicisi (borrow checker) aracılığıyla tüm *çalışma zamanı hatalarını(runtime errors)* ortadan kaldırır. C ve C++'daki gibi performans elde edersiniz bununla birlikte bellek emniyetsizliği sorunları yaşamazsınız. Ayrıca desen eşleştirme (pattern matching) ve yerleşik bağımlılık yönetimi (dependency management) gibi yapılara sahip modern bir dil elde edersiniz.
- Java, Go, Python, JavaScript... ile deneyim: Bu dillerdekiyle aynı bellek emniyetine (safety) ve benzer bir yüksek seviyeli dil hissini elde edersiniz. Ayrıca C ve C++ gibi hızlı ve öngörülebilir performans (çöp toplayıcı yok) ve düşük seviyeli donanıma erişim (ihtiyaç duymanız halinde) elde edersiniz.

4.3 Deneme Alanı (Playground)

Rust Deneme Alanı kısa Rust programlarını çalıştırmanın kolay bir yolunu sunar ve bu kurstaki örnekler ve alıştırmaların temelini oluşturur. Deneme alanında "merhaba-dünya" ile başlayan programı çalıştırmayı deneyin. Deneme alanı birkaç kullanışlı özellik ile birlikte gelir:

- Kodunuzu "standart" şekilde biçimlendirmek için "Tools" altında rustfmt seçeneğini kullanın.
- Rust kodu oluşturmak için iki ana "profil" (profile) vardır: Hata ayıklama (ekstra çalışma zamanı kontrolleri, daha az optimizasyon) ve Sürüm (release) (daha az çalışma zamanı kontrolü, çok fazla optimizasyon). Bunlara üst kısımdaki "Hata Ayıklama" bölümünden erişilebilir.
- Eğer ilgileniyorsanız, oluşturulan asm kodunu görmek için "..." altındaki "ASM"yi kullanın.

Öğrenciler araya girerken onları deneme alanını açmaya ve biraz deney yapmaya teşvik edin. Kursun geri kalanında sekmeyi açık tutmaya ve bir şeyler denemeye teşvik edin. Bu özellikle Rust'ın optimizasyonları veya oluşturulan asm kodu hakkında daha fazla bilgi edinmek isteyen ileri düzey öğrenciler için faydalıdır.

Bölüm 5

Türler ve Değerler

Bu bölüm yaklaşık 40 dakika sürmelidir. İçeriği:

Slayt	Süre
Merhaba, Dünya	5 dakika
Değişkenler	5 dakika
Değerler	5 dakika
Aritmetik	3 dakika
Tür Çıkarımı	3 dakika
Alıştırma: Fibonacci	15 dakika

5.1 Merhaba, Dünya

Mümkün olan en basit Rust programına, klasik bir Merhaba Dünya programına geçelim:

```
fn main() {  
    println!("Merhaba 🌍!");  
}
```

Ne görüyorsunuz:

- Fonksiyonlar `fn` ile tanıılır.
- Bloklar, C ve C++'daki gibi küme parantezleriyle sınırları belirlenmiştir.
- `main` fonksiyon programın giriş noktasıdır (entry point).
- Rust arınmış/pak/izole (hygienic) makrolara sahiptir, `println!` buna bir örnektir.
- Rust dilindeki dizeler (strings) UTF-8 olarak kodlanmıştır ve herhangi bir Unicode karakteri içerebilir.

Bu slayt öğrencilerin Rust kodu konusunda rahat olmalarını sağlamaya çalışmaktadır. Önümüzdeki dört gün içinde çok şey görecekler, bu yüzden aşına bir şeyle küçükten başlıyoruz.

Anahtar noktalar:

- Rust, C/C++/Java geleneğindeki diğer dillere çok benzer. Rust emirli bir dildir (imperative) ve kesinlikle gerekmedikçe bir şeyleri yeniden keşfetmeye çalışmaz.

- Rust, Unicode gibi şeyleri tam olarak destekleyen modern bir yazılımdır.
- Rust, değişken sayıda argümana sahip olmak istediğiniz durumlar için makroları kullanır (fonksiyon [yüklemesi](#) yoktur).
- Makroların 'arınmış/pak' olması, kullanıldıkları kapsamdaki (scope) tanımlayıcıları (identifiers) yanlışlıkla yakalamadıkları anlamına gelir. Rust makroları aslında yalnızca [kısmen hijyeniktir](#).
- Rust çok paradigmatlı bir dildir. Örneğin, güçlü [nesne yönelimli programlama özelliklerine](#) sahiptir ve çeşitli [fonksiyonel kavramları](#) (fonksiyonel bir dil olmasa da) içerir.

5.2 Değişkenler

Rust, statik tür özelliğine sahip olmasıyla tür emniyeti sağlar. Değişken bağlamaları (binding) `let` ile yapılır:

```
fn main() {
    let x: i32 = 10;
    println!("x: {x}");
    // x = 20;
    // println!("x: {x}");
}
```

- Değişkenlerin varsayılan olarak değişmez (immutable) olduğunu göstermek için `x = 20`'in yorum satırını kaldırın. Değişikliklere izin vermek için `mut` anahtar kelimesini ekleyin.
- Buradaki `i32` değişkenin türüdür. Bunun derleme zamanında bilinmesi gerekir, ancak tür çıkarımı (daha sonra ele alınacaktır), programcının birçok durumda bunu atlmasına olanak tanır.

5.3 Değerler

Burada bazı temel yerleşik türler ve her türün değişmez değerlerinin (literal values) sözdizimi (syntax) verilmiştir.

Türler	Değişmezler
İşaretli tamsayılar <code>i8, i16, i32, i64, i128, isize</code>	<code>-10, 0, 1_000, 123_i64</code>
İşaretsiz tamsayılar <code>u8, u16, u32, u64, u128, usize</code>	<code>0, 123, 10_u16</code>
Ondalıkli (floating point) sayılar <code>f32, f64</code>	<code>3.14, -10.0e20, 2_f32</code>
Unicode karakterler <code>char</code>	<code>'a', 'α', '∞'</code>
Boole'sal değerler <code>bool</code>	<code>true, false</code>

Türler	Değişmezler
--------	-------------

Türlerin genişlikleri/boyutları aşağıdaki gibidir:

- `iN`, `uN` ve `fN` türleri N bit genişliğinde,
- `isize` ve `usize` türleri göstericinin genişliğinde,
- `char` türü 32 bit genişliğinde,
- `bool` türü 8 bit genişliğinde.

Yukarıda gösterilmeyen birkaç sözdizimi (syntax) vardır:

- Rakamlardaki tüm alt çizgiler atlanabilir, bunlar yalnızca okunabilirlik içindir. Yani `1_000`, `1000` (veya `10_00`) olarak ve `123_i64`, `123i64` olarak yazılabilir.

5.4 Aritmetik

```
fn interproduct(a: i32, b: i32, c: i32) -> i32 {
    return a * b + b * c + c * a;
}
```

```
fn main() {
    println!("sonuç: {}", interproduct(120, 100, 248));
}
```

İlk defa `main` dışında bir fonksiyon görüyoruz, ancak anlamı açık: üç tamsayı alır ve bir tamsayı döndürür. Fonksiyonlar daha sonra daha detaylı olarak ele alınacaktır.

Aritmetik işlemleri, diğer dillerinkine benzer öncelik sıralamasıyla çok benzerdir.

Peki, tamsayı taşması ne olacak? C ve C++'da *işaretli* tamsayıların taşması aslında tanımsızdır (undefined) ve çalışma zamanında bilinmeyen şeyler olabilir. Rust'ta ise bu tanımlıdır.

Bir hata ayıklama (debug) inşasında paniğe (kontrollü) neden olan ve bir sürüm (release) inşasında sarmalanan (wrap) bir tamsayı taşmasını görmek için `i32`'leri `i16` olarak değiştirin. Taşma (overflow), doyum (saturating), elde (carrying) gibi işlemlerinin kontrolü için başka seçenekler de vardır. Bunlara metod sözdizimi ile erişilir, örneğin `(a * b).saturating_add(b * c).saturating_add(c * a)`.

Aslında derleyici sabit (constant) ifadelerin (expression) taşmasını algılayacaktır, bu nedenle örnek ayrı bir fonksiyon gerektirir.

5.5 Tür Çıkarımı

Rust, türü belirlemek için değişkenin nasıl *kullanıldığına* bakacak:

```
fn takes_u32(x: u32) {
    println!("u32: {x}");
}

fn takes_i8(y: i8) {
    println!("i8: {y}");
}
```



```
fn main() {
    let x = 10;
    let y = 20;

    takes_u32(x);
    takes_i8(y);
    // takes_u32(y);
}
```

Bu slayt, Rust derleyicisinin değişken bildirimleri ve kullanımları tarafından verilen kısıtlamalara dayanarak türleri nasıl çıkarım yaptığını gösterir.

Bu şekilde bildirilen değişkenlerin herhangi bir veriyi tutabilecek dinamik "herhangi bir tür" olmadığını vurgulamak çok önemlidir. Böyle bir bildirim tarafından oluşturulan makine kodu, bir türün açık (explicit) bildiriyle aynıdır. Derleyici bizim için işi yapar ve daha kısa kod yazmamıza yardımcı olur.

Hiçbir şey bir tamsayı değişiminin türünü kısıtlamadığında, Rust varsayılan olarak türü i32 yapar. Bu bazen hata mesajlarında "{integer}" olarak görünür. Benzer şekilde, ondalıklı sayı değişimleri için varsayılan tür f64'tür.

```
fn main() {
    let x = 3.14;
    let y = 20;
    assert_eq!(x, y);
    // HATA: `{float} == {integer}` için gerçekleştirim-uyarlama (implementation) yok
}
```

5.6 Alıştırma: Fibonacci

Fibonacci dizisi $[0, 1]$ ile başlar. $n > 1$ için, n 'inci Fibonacci sayısı yinelemeli olarak $n-1$ 'inci ve $n-2$ 'inci Fibonacci sayılarının toplamı olarak hesaplanır.

n 'inci Fibonacci sayısını hesaplayan bir `fib(n)` fonksiyonu yazın. Bu fonksiyon ne zaman paniğe kapılacak?

```
fn fib(n: u32) -> u32 {
    if n < 2 {
        // Temel durum.
        todo!("Bunu gerçekleştirin (implement)")
    } else {
        // Özyinelemeli durum.
        todo!("Bunu gerçekleştirin (implement)")
    }
}

fn main() {
    let n = 20;
    println!("fib({n}) = {}", fib(n));
}
```

5.6.1 Çözüm

```
fn fib(n: u32) -> u32 {
    if n < 2 {
        return n;
    } else {
        return fib(n - 1) + fib(n - 2);
    }
}

fn main() {
    let n = 20;
    println!("fib({n}) = {}", fib(n));
}
```

Bölüm 6

Kontrol Akışı Temelleri

Bu bölüm yaklaşık 40 dakika sürmelidir. İçeriği:

Slayt	Süre
if İfadeleri	4 dakika
Döngüler	5 dakika
break ve continue	4 dakika
Bloklar ve Kapsamlar	5 dakika
Fonksiyonlar	3 dakika
Makrolar	2 dakika
Alıştırma: Collatz Sekansı	15 dakika

- Şimdi, Rust'ta bulunan birçok akış kontrol çeşitlerini ele alacağız.
- Bunların çoğu diğer programlama dillerinde gördüklerinize çok tanıdık gelecektir.

6.1 if ifadeleri

if ifadelerini tam olarak diğer dillerdeki if deyimleri (statement) gibi kullanabilirsiniz:

```
fn main() {  
    let x = 10;  
    if x == 0 {  
        println!("sıfır!");  
    } else if x < 100 {  
        println!("büyükçe");  
    } else {  
        println!("aşırı büyük");  
    }  
}
```

Ayrıca, if'i ifade (expression) olarak da kullanabilirsiniz. Her bloğun son ifadesi if ifadesinin değeri olur:

```
fn main() {
    let x = 10;
    let size = if x < 20 { "küçük" } else { "büyük" };
    println!("sayının boyutu: {}", size);
}
```

if bir ifade (expression) olduğundan ve belirli bir türe sahip olması gerektiğinden, her iki dal bloğunun da aynı türde olması gerekir. İkinci örnekte "küçük"ten sonra ; eklerseniz ne olacağını gösterin.

Bir if ifadesi diğer ifadelerle aynı şekilde kullanılmalıdır. Örneğin, bir let ifadesinde kullanıldığında, ifadenin ; ile de sonlandırılması gerekir. Derleyici hatasını görmek için println!'den önceki ;'yi kaldırın.

6.2 Döngüler

Rust dilinde üç döngüsel anahtar kelime vardır: while, loop, ve for:

while

while anahtar kelimesi diğer dillerdeki gibi işler ve koşul doğru olduğu sürece döngü gövdesini yürütür (execute).

```
fn main() {
    let mut x = 200;
    while x >= 10 {
        x = x / 2;
    }
    println!("Son x: {x}");
}
```

6.2.1 for

for döngüsü değer aralıkları veya bir koleksiyondaki öğeler üzerinde tekrarlar:

```
fn main() {
    for x in 1..5 {
        println!("x: {x}");
    }

    for elem in [1, 2, 3, 4, 5] {
        println!("elem: {elem}");
    }
}
```

- for döngülerinin başlığının altında, farklı türdeki aralıklar/koleksiyonlar üzerinde tekrarlamayı gerçekleştirmek için "adımlayıcılar" adı verilen bir kavram kullanılır. Adımlayıcılar (iterators) daha sonra daha ayrıntılı olarak tartışılacaktır.
- İlk for döngüsünün yalnızca 4e kadar adım attığını unutmayın. Kapalı bir aralık için 1..=5 sözdizimini gösterin.

6.2.2 loop

loop deyimi, bir **break**'e kadar sonsuz döner.

```
fn main() {
    let mut i = 0;
    loop {
        i += 1;
        println!("{i}");
        if i > 100 {
            break;
        }
    }
}
```

- loop deyimi `while true` döngüsü gibi çalışır. Bağlantılara sonsuza kadar hizmet edecek sunucular gibi şeyler için kullanın.

6.3 break ve continue

Bir sonraki adıma hemen başlamak istiyorsanız **continue** kullanın.

Herhangi bir döngüden erken çıkmak istiyorsanız, **break** kullanın. `loop` ile, `loop` ifadesinin değeri haline gelen isteğe bağlı bir ifade olabilir.

```
fn main() {
    let mut i = 0;
    loop {
        i += 1;
        if i > 5 {
            break;
        }
        if i % 2 == 0 {
            continue;
        }
        println!("{}", i);
    }
}
```

`loop`'un önemsiz olmayan (non-trivial) bir değer döndüren tek döngüsel yapı olduğunu unutmayın. Bunun nedeni, en az bir `break` ifadesinde sonlanmasının garantili olmasıdır (koşul başarısız olduğunda da sonlanabilen `while` ve `for` döngülerinin aksine).

6.3.1 Etiketler

Hem `continue` ve `break` isteğe bağlı olarak iç içe geçmiş döngülerden çıkmak için kullanılan bir etiket (label) argümanını alabilir:

```
fn main() {
    let s = [[5, 6, 7], [8, 9, 10], [21, 15, 32]];
    let mut elements_searched = 0;
    let target_value = 10;
    'outer: for i in 0..=2 {
```

```

        for j in 0..=2 {
            elements_searched += 1;
            if s[i][j] == target_value {
                break 'outer;
            }
        }
    }
    print!("aranan öğeler: {elements_searched}");
}

```

- Etiketli break, keyfi olarak yazılan bloklarda da çalışır, örneğin.

```

'label: {
    break 'label;
    println!("Bu satır geçilece");
}

```

6.4 Bloklar ve Kapsamlar

Bloklar

Rust dilindeki bir blok, {} parantezleri içine alınmış bir ifadeler dizisi (sequence of expressions) içerir. Her bloğun, bloğun son ifadesine ait olan bir değeri ve türü vardır:

```

fn main() {
    let z = 13;
    let x = {
        let y = 10;
        println!("y: {y}");
        z - y
    };
    println!("x: {x}");
}

```

Son ifade ; ile bitiyorsa, ortaya çıkan değer ve tür () olur.

- Bloktaki son satırı değiştirerek bloğun değerinin nasıl değiştiğini gösterebilirsiniz. Örneğin, noktalı virgül eklemek/kaldırmak veya bir return kullanmak.

6.4.1 Kapsamlar (Scopes) ve Gölgeleme (Shadowing)

Bir değişkenin kapsamı (scope) onu çevreleyen blokla sınırlıdır.

Hem dış kapsamlardaki (outer scopes) değişkenleri hem de aynı kapsamdaki değişkenleri gölgeleyebilirsiniz (shadow):

```

fn main() {
    let a = 10;
    println!("önce: {a}");
    {
        let a = "merhaba";
        println!("iç kapsam: {a}");
    }

    let a = true;
}

```

```

    println!("iç kapsamda gölgelendi: {a}");
}

println!("sonra: {a}");
}

```

- Son örnekte iç bloğa (inner block) bir b ekleyerek ve ardından bu bloğun dışından ona erişmeye çalışarak bir değişkenin kapsamının (scope) sınırlı olduğunu gösterin.
- Gölgeleme (shadowing) mutasyondan (mutation) farklıdır çünkü gölgeleme sonrasında her iki değişkenin de bellek konumları aynı anda mevcuttur. Her ikisi de kodda nerede kullandığınıza bağlı olarak aynı ad altında mevcuttur.
- Bir gölgeleme (shadowing) değişkeni farklı bir türe sahip olabilir.
- Gölgeleme ilk başta anlaşılmasız görünebilir, ancak `.unwrap()` sonrasındaki değerleri korumak için kullanışlıdır.

6.5 Fonksiyonlar

```

fn gcd(a: u32, b: u32) -> u32 {
    if b > 0 {
        gcd(b, a % b)
    } else {
        a
    }
}

fn main() {
    println!("gcd: {}", gcd(143, 52));
}

```

- Bildirim (declaration) parametrelerinin ardından bir tür (bazı programlama dillerinin tersi) ve ardından bir dönüş türü gelir.
- Bir fonksiyon gövdesindeki (veya herhangi bir bloktaki) son ifade (expression), geri dönüş değeri (return value) olur. İfadenin sonundaki `;` işaretini silmeniz yeterlidir. `return` anahtar kelimesi erken geri dönüş (early return) için kullanılabilir, ancak "yalın (bare) değer" formu bir fonksiyonun sonunda tercih edilen yaklaşımdır (idiomatic) (return kullanmak için `gcd`'yi yeniden düzenleyin - refactor).
- Bazı fonksiyonların dönüş değeri (return value) yoktur ve 'birim türü (unit type)', `()` döndürürler. Eğer dönüş türü yazılmazsa, derleyici birim türünü çıkarım (infer) yapacaktır.
- Yükleme (overloading) desteklenmez -- her fonksiyonun tek bir uygulaması (implementation) vardır.
 - Her zaman sabit sayıda parametre alır. Varsayılan argümanlar (default arguments) desteklenmez. Makrolar değişken sayıda argüman alan fonksiyonları (variadic functions) desteklemek için kullanılabilir.
 - Her zaman tek bir parametre türü kümesini alır. Bu türler, daha sonra ele alınacak olan jenerik olabilir.

6.6 Makrolar

Makrolar, derleme sırasında Rust koduna genişletilir ve değişken sayıda argüman alabilir. Sonunda ! işaretiyle ayırt edilirler. Rust standart kütüphanesi çeşitli yararlı makrolar içerir.

- `println!(format, ..), std::fmt`'de açıklanan biçimi uygulayarak standart çıktıya bir satır yazdırır.
- `format!(format, ..)` tıpkı `println!` gibi işler ancak sonucu bir dize (string) olarak geri döndürür.
- `dbg!(expression)` ifadenin değerini kayıt tutar (logging) ve onu geri döndürür.
- `todo!()` kodun bir kısmını henüz uygulanmamış (not-yet-implemented) olarak işaretler. Eğer yürütülürse (execute), paniğe neden olur.
- `unreachable!()` kodun bir kısmını erişilemez (unreachable) olarak işaretler. Eğer yürütülürse, paniğe neden olur.

```
fn factorial(n: u32) -> u32 {
    let mut product = 1;
    for i in 1..=n {
        product *= dbg!(i);
    }
    product
}

fn fizzbuzz(n: u32) -> u32 {
    todo!()
}

fn main() {
    let n = 4;
    println!("{n}! = {}", factorial(n));
}
```

Bu bölümden çıkarılacak sonuç, bu ortak kolaylıkların mevcut olduğu ve bunların nasıl kullanılacağıdır. Bunların neden makro olarak tanımlandığı ve neye genişledikleri özellikle kritik değildir.

Kurs, makroların tanımlanmasını (define) kapsamaz, ancak daha sonraki bir bölümde türetilmiş makroların kullanımı anlatılacaktır.

6.7 Alıştırma: Collatz Sekansı

Collatz sayısı, sıfırdan büyük herhangi bir n

1

için aşağıdaki şekilde tanımlanır:

- Eğer $*n$
i
* 1 ise, dizi $*n$
i

*'de sonlanır.

- Eğer *n

i

* çift ise, o zaman *n

i+1

= n

i

/ 2*.

- Eğer *n

i

* tek sayı ise *n

i+1

= 3 * n

i

+ 1*.

Örneğin, *n

1

* = 3 ile başlırsak:

- 3 tek sayıdır, dolayısıyla *n

2

* = 3 * 3 + 1 = 10;

- 10 çift sayıdır, dolayısıyla *n

3

* = 10 / 2 = 5;

- 5 tek sayıdır, dolayısıyla *n

4

* = 3 * 5 + 1 = 16;

- 16 çift sayıdır, dolayısıyla *n

5

* = 16 / 2 = 8;

- 8 çift sayıdır, dolayısıyla *n

6

* = 8 / 2 = 4;

- 4 çift sayıdır, dolayısıyla *n

7

* = 4 / 2 = 2;

- 2 çifttir, bu yüzden *n

8

* = 1; ve

- sekans sonlandırılır.

Belirli bir başlangıç n için collatz sekansının uzunluğunu hesaplayan bir fonksiyon yazın.

```
/// `n`'den başlayan collatz sekansının uzunluğunu belirle.
```

```
fn collatz_length(mut n: i32) -> u32 {  
    todo!("Bunu gerçekleştirin (implement)")  
}
```

```
fn test_collatz_length() {  
    assert_eq!(collatz_length(11), 15);  
}
```

```
fn main() {  
    println!("Length: {}", collatz_length(11));  
}
```

6.7.1 Çözüm

```
/// `n`'den başlayan collatz sekansının uzunluğunu belirle.
```

```
fn collatz_length(mut n: i32) -> u32 {  
    let mut len = 1;  
    while n > 1 {  
        n = if n % 2 == 0 { n / 2 } else { 3 * n + 1 };  
        len += 1;  
    }  
    len  
}
```

```
fn test_collatz_length() {  
    assert_eq!(collatz_length(11), 15);  
}
```

```
fn main() {  
    println!("Length: {}", collatz_length(11));  
}
```

Kısım II

Gün 1: Öğleden Sonra

Bölüm 7

Tekrar Hoş Geldiniz

10 dakikalık aralar, bu oturum yaklaşık 2 saat 35 dakika sürmelidir. İçeriği:

Bölüm	Süre
Demetler (Tuples) ve Diziler (Arrays)	35 dakika
Referanslar	55 dakika
Kullanıcı Tanımlı Türler	50 dakika

Bölüm 8

Demetler (Tuples) ve Diziler (Arrays)

Bu bölüm yaklaşık 35 dakika sürmelidir. İçeriği:

Slayt	Süre
Diziler	5 dakika
Demetler	5 dakika
Dizi Adımlama (Iteration)	3 dakika
Desenler ve Çözümleme (Destructuring)	5 dakika
Alıştırma: İççe Diziler	15 dakika

- Rust'ta (primitive) ilkel türlerin nasıl çalıştığını gördük. Şimdi yeni bileşik (composite) türler oluşturmaya başlamanın zamanı geldi.

8.1 Diziler

```
fn main() {  
    let mut a: [i8; 10] = [42; 10];  
    a[5] = 0;  
    println!("a: {a:?}");  
}
```

- Bir $[T; N]$ dizi türünün değeri , aynı T türdeki N (derleme zamanı sabiti) öğelerini/elemanlarını tutar. Dizinin uzunluğunun *türünün parçası* olduğuna dikkat edin, bu da `[u8; 3]` ve `[u8; 4]` dizilerinin iki farklı tür olarak kabul edildiği anlamına gelir. Dilimler (slices), ki çalışma zamanında belirlenen bir boyuta sahiptir, daha sonra ele alınacaktır.
- Sınırların dışında bir dizi öğesine erişmeyi deneyin. Dizi erişimleri çalışma zamanında (runtime) kontrol edilir. Rust genellikle bu kontrolleri optimize edebilir ve emniyetsiz Rust (unsafe Rust) kullanılarak bu kontrollerden kaçınılabilir.
- Dizilere değer atamak için değişmezleri (literals) kullanabiliriz.

- `println!` makrosu ? biçim (format) parametresiyle hata ayıklama gerçekleştirimini/uyarlamasını (implementation) ister: `{}` varsayılan çıktıyı verir, `{: ?}` hata ayıklama çıktısını verir. Tamsayılar (integer) ve dizeler (string) gibi türler varsayılan çıktıyı uygular (default output), ancak diziler (arrays) yalnızca hata ayıklama çıktısını (debug output) uygular. Bu, bahsi geçen kodda hata ayıklama çıktısını kullanmamız gerektiği anlamına gelir.
- # eklemek, örneğin `{a: #?}`, okunması daha kolay olabilecek "güzel yazdırma (pretty printing)" biçimini (format) çağırır.

8.2 Demetler

```
fn main() {
  let t: (i8, bool) = (7, true);
  println!("t.0: {}", t.0);
  println!("t.1: {}", t.1);
}
```

- Diziler gibi, demetlerin (tuple) de sabit bir uzunluğu vardır.
- Demetler farklı türdeki değerleri bir bileşik tür (compound type) halinde gruplandırır.
- Bir demetin alanlarına (fields) nokta ve değer indexi ile erişilebilir, örneğin `t.0`, `t.1`.
- Boş demet `()`, "birim türü (unit type)" olarak anılır ve, diğer dillerdeki `void`'e benzer şekilde, bir geri dönüş değerinin (return value) bulunmadığını belirtir.

8.3 Dizi Adımlama (Iteration)

'for' deyimi diziler üzerinde adımlamayı/dolaşmayı destekler (ancak demetler (tuples) üzerinde desteklemez).

```
fn main() {
  let primes = [2, 3, 5, 7, 11, 13, 17, 19];
  for prime in primes {
    for i in 2..prime {
      assert_ne!(prime % i, 0);
    }
  }
}
```

Bu fonksiyonellik `IntoIterator` özelliğini (trait) kullanıyor, ancak bunu henüz ele almadık.

`assert_ne!` makrosu burada yenidir. Ayrıca `assert_eq!` ve `assert!` makroları da vardır. Bunlar her zaman kontrol edilirken, `debug_assert!` gibi yalnızca hata ayıklama varyantları sürüm inşasında (release build) hiçbir şeye derlenmez.

8.4 Desenler ve Çözümleme (Destructuring)

Demetler (tuples) ve diğer yapılandırılmış değerlerle (structured values) çalışırken, içteki değerleri yerel (local) değişkenlere çıkarmayı istemek yaygındır. Bu, doğrudan iç değerlere erişilerek elle yapılabilir:

```
fn print_tuple(tuple: (i32, i32)) {
    let left = tuple.0;
    let right = tuple.1;
    println!("sol: {left}, sağ: {right}");
}
```

Ancak, Rust daha büyük bir değeri kendisini oluşturan parçalara çözümlmek (destructure) için desen eşleştirmeyi (pattern matching) kullanmayı da destekliyor:

```
fn print_tuple(tuple: (i32, i32)) {
    let (left, right) = tuple;
    println!("sol: {left}, sağ: {right}");
}
```

- Burada kullanılan desenler "reddedilemez (irrefutable)"dir, yani derleyici = sağındaki değerin desenle aynı yapıya sahip olduğunu statik olarak doğrulayabilir.
- Bir değişken adı, her zaman herhangi bir değerle eşleşen reddedilemez (irrefutable) bir desendir, bu nedenle tek bir değişkeni bildirmek için let'i kullanabiliriz.
- Rust ayrıca koşullu ifadelerde desenlerin (patterns) kullanılmasını destekleyerek eşitlik karşılaştırmasının (comparison) ve çözümlenmenin (destructuring) aynı anda gerçekleşmesine olanak tanır. Bu desen eşleştirme stili daha sonra daha ayrıntılı olarak tartışılacaktır.
- Desenin (pattern) eşleştirilen değerle eşleşmediğinde oluşacak derleyici hatasını göstermek için yukarıdaki örnekleri düzenleyin.

8.5 Alıştırma: İççe Diziler

Diziler başka diziler de içerebilir:

```
let array = [[1, 2, 3], [4, 5, 6], [7, 8, 9]];
```

Bu değişkenin türü nedir?

Bir matrisin devrini yapacak (satırları sütunlara çevirecek) transpose fonksiyonu yazmak için yukarıdaki gibi bir dizi kullanın:

```
"transpose" | [[1 2 3]] | "==" | [1 4 7]
              | [4 5 6] |      | [2 5 8]
              | [7 8 9] |      | [3 6 9]
```

Aşağıdaki kodu <https://play.rust-lang.org/> adresine kopyalayın ve fonksiyonu uygulayın (implement). Bu fonksiyon yalnızca 3x3'lük matrislerde çalışır.

// **TODO:** uyarılmanız (implementation) bittiğinde bu yorum satırını silin.

```
fn transpose(matrix: [[i32; 3]; 3]) -> [[i32; 3]; 3] {
    unimplemented!()
}

fn test_transpose() {
    let matrix = [
        [101, 102, 103], //
        [201, 202, 203],
        [301, 302, 303],
    ]
}
```

```

];
let transposed = transpose(matrix);
assert_eq!(
    transposed,
    [
        [101, 201, 301], //
        [102, 202, 302],
        [103, 203, 303],
    ]
);
}

fn main() {
    let matrix = [
        [101, 102, 103], // <-- bu yorum, rustfmt'nin yeni satır eklemesini sağlar
        [201, 202, 203],
        [301, 302, 303],
    ];

    println!("matrix: {:#?}", matrix);
    let transposed = transpose(matrix);
    println!("transposed: {:#?}", transposed);
}

```

8.5.1 Çözüm

```

fn transpose(matrix: [[i32; 3]; 3]) -> [[i32; 3]; 3] {
    let mut result = [[0; 3]; 3];
    for i in 0..3 {
        for j in 0..3 {
            result[j][i] = matrix[i][j];
        }
    }
    result
}

fn test_transpose() {
    let matrix = [
        [101, 102, 103], //
        [201, 202, 203],
        [301, 302, 303],
    ];
    let transposed = transpose(matrix);
    assert_eq!(
        transposed,
        [
            [101, 201, 301], //
            [102, 202, 302],
            [103, 203, 303],
        ]
    );
}

```



```
}  
  
fn main() {  
    let matrix = [  
        [101, 102, 103], // <-- bu yorum, rustfmt'nin yeni satır eklemesini sağlar  
        [201, 202, 203],  
        [301, 302, 303],  
    ];  
  
    println!("matrix: {:#?}", matrix);  
    let transposed = transpose(matrix);  
    println!("transposed: {:#?}", transposed);  
}
```

Bölüm 9

Referanslar

Bu bölüm yaklaşık 55 dakika sürmelidir. İçerir:

Slayt	Süre
Paylaşılan Referanslar	10 dakika
Özel (Exclusive) Referanslar	10 dakika
Dilimler (Slices)	10 dakika
Dizeler (Strings)	10 dakika
Alıştırma: Geometri	15 dakika

9.1 Paylaşılan Referanslar

Bir referans, değer in sahipliğini almadan başka bir değere erişmenin bir yolunu sağlar ve "ödünç alma (borrowing)" olarak da adlandırılır. Paylaşılan referanslar (shared reference) salt okunurdur (read-only) ve referans edilen veriler değiştirilemez.

```
fn main() {  
    let a = 'A';  
    let b = 'B';  
    let mut r: &char = &a;  
    println!("r: {}", *r);  
    r = &b;  
    println!("r: {}", *r);  
}
```

T türüne yönelik paylaşılan referansın türü &T'dir. & operatörüyle bir referans değeri (reference value) oluşturulur. * operatörü bir referansın içeriğine erişir (dereference) ve onun değerini verir.

Rust, boşa düşen referansları (dangling references) statik olarak yasaklayacaktır:

```
fn x_axis(x: &i32) -> &(i32, i32) {  
    let point = (*x, 0);  
    return &point;  
}
```

- Rust'ta referanslar hiçbir zaman null olamaz, bu yüzden null kontrolü (null checking) gerekli değildir.
- Bir referansın, atıfta bulunduğu (refer) değeri "ödünç aldığı (barrow)" söylenir ve bu, göstericilere aşina olmayan öğrenciler için iyi bir modeldir: kod, değere erişmek için referansı kullanabilir, ancak değer yine de orijinal değişken tarafından "sahiplidir (owned)". Kurs, 3. günde sahiplik (ownership) konusunda daha ayrıntılı bilgi verecektir.
- Referanslar göstericiler (pointers) olarak uyarlanır/uygulanır (implement) ve önemli bir avantaj şudur ki, gösterdikleri şeyin boyutundan çok daha küçük olabilmeleridir. C veya C++'a aşina olan öğrenciler referansları göstericiler olarak tanıyacaklardır. Kursun ilerleyen bölümlerinde Rust'ın, ham göstericilerin (raw pointers) kullanılmasından kaynaklanan bellek emniyeti hatalarını (memory-safety bugs) nasıl önlediği ele alınacaktır.
- Rust sizin için otomatik olarak referans oluşturmaz. & her zaman gereklidir.
- Rust bazı durumlarda, özellikle de metotları çağırırken (`r.is_ascii()`'i deneyin) otomatik olarak referansın içeriğine erişecektir (auto-dereference). C++'daki gibi `->` operatörüne gerek yoktur.
- Bu örnekte, `r` değiştirilebilir (mutable) olduğundan ona tekrar atama yapılabilir (reassigned) (`r = &b`). Bunun `r`'yi yeniden bağladığını (re-bind) ve böylece başka bir şeye atıfta bulunduğunu (refer) unutmayın. Bu C++ dilinden, bir referansa atanmanın (assignment) referans verilenin değerini değiştirmesinden, farklıdır.
- Paylaşılan bir referans (shared reference), atıfta bulunduğu (refer) değerini değiştirilmesine (modify), bu değer değiştirilebilir (mutable) olsa bile, izin vermez. `*r = 'X'`'i deneyin.
- Rust, yeterince uzun süre hayatta olmalarını sağlamak için tüm referansların ömrülerini (lifetime) takip eder. Emniyetli Rust'ta boşa çıkan referanslar (dangling reference) oluşamaz. `x_axis` fonksiyonu, `point`'e bir referans geri döndürecek, ancak fonksiyon geri döndüğünde `point` için tahsis edilen alan geri verileceğinden (deallocation) bu kod derlenmeyecektir.
- Sahipliğe (ownership) geçince ödünç alma (borrowing) konusunu daha detaylı konuşacağız.

9.2 Özel (Exclusive) Referanslar

Değiştirilebilir referanslar (mutable reference) olarak da bilinen özel (exclusive) referanslar, atıfta buldukları (refer) değerini değiştirilmesine olanak tanır. `&mut T` türüne sahiplerdir.

```
fn main() {
    let mut point = (1, 2);
    let x_coord = &mut point.0;
    *x_coord = 20;
    println!("point: {point:?}");
}
```

Anahtar noktalar:

- "Özel (exclusive)", değere erişmek için yalnızca bu referansın kullanılabileceği anlamına gelir. Aynı anda başka hiçbir referans (paylaşılan veya özel olsun farketmez) mevcut

olamaz ve özel referans (exclusive) varken atıfta bulunan değere erişilemez. `x_coord` hayattayken bir `&point.0` oluşturmayı veya `point.0`'ı değiştirmeyi deneyin.

- `let mut x_coord: &i32` ve `let x_coord: &mut i32` arasındaki farka dikkat ettiğinizden emin olun. Birincisi, farklı değerlere bağlanabilen (bind) paylaşılan bir referansı (shared reference) temsil ederken, ikincisi, değiştirilebilir bir değere (mutable value) özel bir referansı (exclusive reference) temsil eder (represent).

9.3 Dilimler (Slices)

Bir dilim (slice) size daha büyük bir koleksiyonun içinden bir görüntü verir:

```
fn main() {
    let mut a: [i32; 6] = [10, 20, 30, 40, 50, 60];
    println!("a: {a:?}");

    let s: &[i32] = &a[2..4];

    println!("s: {s:?}");
}
```

- Dilimler (slice), dilimlenmiş türden verileri ödünç alır (borrowing).
- `a`'yı ödünç alıp (borrowing) başlangıç ve bitiş indekslerini köşeli parantez içinde belirterek bir dilim (slice) oluşturuyoruz.
- Dilim (slice) indeks 0'da başlıyorsa, Rust'ın aralık sözdizimi (range syntax) başlangıç indeksini kullanmamaya izin verir; bu, `&a[0..a.len()]` ve `&a[..a.len()]` dilimlerinin aynı olduğu anlamına gelir.
- Aynı şey bitiş indeksi için de geçerlidir, dolayısıyla `&a[2..a.len()]` ve `&a[2..]` aynıdır.
- Tüm bir dizinin dilimini (slice) kolayca oluşturmak için `&a[. .]`'ı kullanabiliriz.
- `s, i32`'lerin bir dilimine (slice) referanstır. `s (&[i32])` türünün artık dizi uzunluğundan bahsetmediğine dikkat edin. Bu bize farklı boyutlardaki dilimler üzerinde hesaplama yapmamızı sağlar.
- Dilimler (slice) her zaman başka bir nesneden ödünç alır (borrow). Bu örnekte `a`'nın en azından dilimimiz (slice) kadar 'canlı (alive)' (kapsamında) kalması gerekiyor.

9.4 Dizeler (Strings)

Artık Rust'taki iki dize (string) türünü anlayabiliyoruz:

- `&str`, `&[u8]`e benzer şekilde, UTF-8 olarak kodlanmış baytların bir dilimidir (slice).
- `String`, `Vec<T>`ye benzer şekildedir, UTF-8 olarak kodlanmış baytlardan oluşan sahipli bir arabellektir.

```
fn main() {
    let s1: &str = "Dünya";
    println!("s1: {s1}");
}
```

```

let mut s2: String = String::from("Merhaba ");
println!("{}", s2);
s2.push_str(s1);
println!("{}", s2);

let s3: &str = &s2[s2.len() - s1.len()..];
println!("{}", s3);
}

```

- `&str`, bir bellek bloğunda saklanan UTF-8 olarak kodlanmış dize (string) verilerine değiştirilemez (immutable) referans olan bir dize dilimi (string slice) sunar. Dize değişmezleri (string literals) ("Hello"), programın ikili (binary) dosyasında saklanır.
- Rust'ın `String` türü, baytlardan oluşan bir vektörün bir sarmalayıcı türüdür. Bir `Vec<T>` gibi, bu türden veri `String` türü tarafından sahiplidir (owned).
- Diğer birçok türde olduğu gibi, `String::from()` bir dize değişmezinden (string literal) bir string oluşturur; `String::new()` yeni bir boş dize oluşturur ve dizeye veriler `push()` ve `push_str()` metotları kullanılarak eklenebilir.
- `format!()` makrosu, dinamik değerlerden sahipli bir dize oluşturmak için uygun bir yoldur. Aynı biçimin `println!()` makrosundaki gibi aynı biçim tanımlamasını kabul eder.
- `String`'den `&str` dilimlerini (slices) `&` ve isteğe bağlı olarak aralık seçimi (range selection) ile ödünç alabilirsiniz (borrow). Karakter sınırlarının dışını da kapsayacak bir bayt aralığı seçerseniz, ifade (expression) paniğe neden olacaktır. `chars` adımlayıcısı, karakterler üzerinde adımlama yapar ve karakter sınırlarını doğru bulmaya çalışmak yerine tercih edilir.
- C++ programcıları için: `&str`'yi C++'daki `std::string_view` olarak düşünün, ancak her zaman bellekteki geçerli bir dizeye işaret eder. Rust dilindeki `String`, C++'daki `std::string`'in kabaca eşdeğeridir (ana fark: yalnızca UTF-8 olarak kodlanmış baytlar içerebilir ve asla küçük dize optimizasyonu / small-string optimization kullanmaz).
- Bayt dizelerinden değişmezler (Byte strings literals), doğrudan bir `&[u8]` değeri oluşturmanıza olanak tanır:

```

fn main() {
    println!("{}", b"abc");
    println!("{}", &[97, 98, 99]);
}

```

- Ham (raw) dizeler, kaçış karakterlerinin devre dışı bırakıldığı bir `&str` değeri oluşturmanıza olanak tanır: `r"\n" == "\\n"`. Dizenin içindeki çift tırnakları, dizeyi oluşturan tırnakların her iki tarafına eşit sayıda `#` karakteri koyarak görebilirsiniz:

```

fn main() {
    println!(r#"<a href="link.html">link</a>"#);
    println!("{}", <a href="link.html">link</a>");
}

```

9.5 Alıştırma: Geometri

3 boyutlu geometri için, bir noktayı `[f64; 3]` olarak temsil eden birkaç yardımcı fonksiyon oluşturacağız. Fonksiyon imzalarını belirlemek size kalmış.

```
// Bir vektörün büyüklüğünü, koordinatlarının karelerini toplayarak hesaplayın
// ve karekökünü alın. Karekökü hesaplamak için `sqrt()` metodunu kullanın,
// örneğin `v.sqrt()` gibi.
```

```
fn magnitude(...) -> f64 {
    todo!()
}
```

```
// Bir vektörü, büyüklüğünü hesaplayarak ve tüm koordinatlarını bu büyüklüğe
// bölerek normalize edin.
```

```
fn normalize(...) {
    todo!()
}
```

```
// Çalışmanızı test etmek için aşağıdaki `main` fonksiyonunu kullanın.
```

```
fn main() {
    println!("Birim vektörünün büyüklüğü: {}", magnitude(&[0.0, 1.0, 0.0]));

    let mut v = [1.0, 2.0, 9.0];
    println!("{v:?} vektörünün büyüklüğü: {}", magnitude(&v));
    normalize(&mut v);
    println!("Normalize edildikten sonra {v:?} vektörünün büyüklüğü: {}", magnitude(&v))
}
```

9.5.1 Çözüm

```
/// Verilen vektörün büyüklüğünü hesaplayın.
```

```
fn magnitude(vector: &[f64; 3]) -> f64 {
    let mut mag_squared = 0.0;
    for coord in vector {
        mag_squared += coord * coord;
    }
    mag_squared.sqrt()
}
```

```
/// Vektörün büyüklüğünü, yönünü değiştirmeden 1.0'a değiştirin.
```

```
fn normalize(vector: &mut [f64; 3]) {
    let mag = magnitude(vector);
    for item in vector {
        *item /= mag;
    }
}
```

```
fn main() {  
    println!("Birim vektörünün büyüklüğü: {}", magnitude(&[0.0, 1.0, 0.0]));  
  
    let mut v = [1.0, 2.0, 9.0];  
    println!("{v:?} vektörünün büyüklüğü: {}", magnitude(&v));  
    normalize(&mut v);  
    println!("Normalize edildikten sonra {v:?} vektörünün büyüklüğü: {}", magnitude(&v));  
}
```

Bölüm 10

Kullanıcı Tanımlı Türler

Bu bölüm yaklaşık 50 dakika sürmelidir. İçeriği:

Slayt	Süre
İsimli Yapılar	10 dakika
Demet Yapıları (Tuple Structs)	10 dakika
Enumlar	5 dakika
Static	5 dakika
Tür Eş İsimleri (Type Aliases)	2 dakika
Alıştırma: Asansör Olayları	15 dakika

10.1 İsimli Yapılar

C ve C++ dillerindeki gibi Rust'ın da özel (kullanıcı tanımlı) yapılara desteği vardır:

```
struct Person {
    name: String,
    age: u8,
}

fn describe(person: &Person) {
    println!("{} {} yaşında", person.name, person.age);
}

fn main() {
    let mut peter = Person { name: String::from("Peter"), age: 27 };
    describe(&peter);

    peter.age = 28;
    describe(&peter);

    let name = String::from("Avery");
    let age = 39;
    let avery = Person { name, age };
}
```



```

describe(&avery);

let jackie = Person { name: String::from("Jackie"), ..avery };
describe(&jackie);
}

```

Önemli Noktalar:

- Yapılar C veya C++'daki gibi çalışır.
 - C++'daki gibi ve C'den farklı olarak, bir türü tanımlamak için `typedef`'e gerek yoktur.
 - C++'dan farklı olarak yapılar arasında kalıtım (inheritance) yoktur.
- Bu, insanlara farklı yapı türleri olduğunu duyurmak için iyi bir zaman olabilir.
 - Sıfır boyutlu (zero-sized) yapılar (örn. `struct Foo;`), bir özelliği (trait) bazı türlere uygularken kullanılabilir, ancak değerin kendisinde saklamak istediğiniz herhangi bir veri yoktur.
 - Sonraki slaytta alan adları (field names) önemli olmadığında kullanılan Demet (Tupe) yapıları tanıtılacaktır.
- Eğer zaten doğru adlara sahip değişkenleriniz varsa, o zaman yapıyı bir kısaltma kullanarak oluşturabilirsiniz.
- `..avery` sözdizimi, eski yapıdaki alanların çoğunu, hepsini açıkça yazmamıza gerek kalmadan kopyalamamıza olanak tanır. Bu her zaman son öge olmalıdır.

10.2 Demet Yapıları (Tuple Structs)

Alan adları (field names) önemsizse demet (tuple) yapısını kullanabilirsiniz:

```

struct Point(i32, i32);

fn main() {
    let p = Point(17, 23);
    println!("{}", p.0, p.1);
}

```

Bu genellikle tek alanlı sarmalayıcılar (single-field wrappers - newtype deseni olarak adlandırılır) için kullanılır:

```

struct PoundsOfForce(f64);
struct Newtons(f64);

fn compute_thruster_force() -> PoundsOfForce {
    todo!("NASA'daki bir roket bilim adamına sorun")
}

fn set_thruster_force(force: Newtons) {
    // ...
}

fn main() {
    let force = compute_thruster_force();
    set_thruster_force(force);
}

```

- Yeni tür (newtype) deseni, ilkel (primitive) bir türdeki değer hakkındaki ek bilgileri kodlamanın harika bir yoludur, örneğin:
 - Sayı bazı birimlerde ölçülür: Yukarıdaki örnekte Newtons.
 - Değer, oluşturulduğunda bir miktar doğrulamadan geçti, bu nedenle artık onu her kullanımda yeniden doğrulamanız gerekmiyor: `PhoneNumber(String)` veya `OddNumber(u32)`.
- Yeni türde desenindeki tek alana erişerek bir Newtons türüne f64 değerinin nasıl ekleneceğini gösterin.
 - Rust genellikle bir nesnenin değerinin otomatik çözülmesini (automatic unwrapping) veya boole değerlerini tamsayı olarak kullanmak gibi açık olmayan şeylerden hoşlanmaz.
 - Operatör yüklemesi 3. günde (jenerikler) tartışıldı.
- Örnek, **Mars İklim Yörünge Aracı** hatasına incelikli bir göndermedir.

10.3 Enumlar

'enum' anahtar sözcüğü birkaç farklı varyanta sahip bir türün yaratılmasına olanak sağlar:

```
enum Direction {
    Left,
    Right,
}

enum PlayerMove {
    Pass, // Basit (simple) varyant
    Run(Direction), // Demet (Tuple) varyantı
    Teleport { x: u32, y: u32 }, // Yapı (Struct) varyantı
}

fn main() {
    let player_move: PlayerMove = PlayerMove::Run(Direction::Left);
    println!("Sıradaki hamle: {player_move:?}");
}
```

Önemli Noktalar:

- Numaralandırmalar, bir dizi değeri tek bir tür altında toplamanıza olanak tanır.
- `Direction`, varyantları olan bir türdür. `Direction`'in iki değeri vardır: `Direction::Left` ve `Direction::Right`.
- `PlayerMove` üç varyantı olan bir türdür. Rust, varyant değerlerine (variant payloads) ek olarak, çalışma zamanında hangi varyantın `PlayerMove` değerinde olduğunu bilmesi için bir ayırıcı (discriminant) da depolayacaktır.
- Bu, yapıları ve numaralandırmaları karşılaştırmak için iyi bir zaman olabilir:
 - Her ikisinde de, alanları olmayan basit bir versiyona (birim yapı) veya farklı alan türlerine sahip bir versiyona (varyant yükleri) sahip olabilirsiniz.
 - Bir enum'un farklı varyantlarını ayrı yapılarla bile uygulayabilirsiniz ancak o zaman da hepsi bir enum'da tanımlanmış olduğunda olacağı gibi aynı türde olmazlardı.
- Rust, ayırıcıyı (discriminant) depolamak için minimum alan kullanır.
 - Gerekirse, gereken en küçük boyuttaki bir tam sayıyı depolar
 - İzin verilen varyant değerleri tüm bit desenlerini kapsamıyorsa, ayırıcıyı kodlamak için geçersiz bit desenleri kullanır ("niş/oyuk/niche optimizasyonu"). Örneğin,

Option<u8>, None varyantı için bir tamsayıya gösterici veya NULL depolar.

- Gerekirse ayırıcıyı kontrol edebilirsiniz (örneğin, C ile uyumluluk için):

```
enum Bar {
    A, // 0
    B = 10000,
    C, // 10001
}

fn main() {
    println!("A: {}", Bar::A as u32);
    println!("B: {}", Bar::B as u32);
    println!("C: {}", Bar::C as u32);
}
```

repr olmadan, ayırıcı tür 2 baytlık olur, çünkü 10001 2 bayta sığar.

Daha Fazlasını Keşfedin

Rust, enum'ların daha az yer kaplamasını sağlamak için kullanabileceği çeşitli optimizasyonlara sahiptir.

- Null gösterici optimizasyonu: **Bazı türler** için, Rust `size_of::<T>()`'nin `size_of::<Option<T>>()`'ye eşit olduğunu garanti eder.

Bitsel gösterimin pratikte nasıl *görünebileceğini* göstermek istiyorsanız örnek kod aşağıdadır. Derleyicinin bu gösterimle (representation) ilgili hiçbir garanti sağlamadığını, dolayısıyla bunun tamamen emniyetsiz olduğunu belirtmek önemlidir.

```
use std::mem::transmute;
```

```
macro_rules! dbg_bits {
    ($e:expr, $bit_type:ty) => {
        println!("- {}: {:#x}", stringify!($e), transmute::<_, $bit_type>($e));
    };
}
```

```
fn main() {
    unsafe {
        println!("bool:");
        dbg_bits!(false, u8);
        dbg_bits!(true, u8);

        println!("Option<bool>:");
        dbg_bits!(None::<bool>, u8);
        dbg_bits!(Some(false), u8);
        dbg_bits!(Some(true), u8);

        println!("Option<Option<bool>>:");
        dbg_bits!(Some(Some(false)), u8);
        dbg_bits!(Some(Some(true)), u8);
        dbg_bits!(Some(None::<bool>), u8);
        dbg_bits!(None::<Option<bool>>, u8);
    }
}
```

```

        println!("Option<i32>:");
        dbg_bits!(None::<i32>, usize);
        dbg_bits!(Some(&0i32), usize);
    }
}

```

10.4 const

Sabitler (constants) derleme zamanında (compile-time) değerlendirilir ve değerleri kullanıldıkları her yerde satır içi (inline) olarak belirtilir:

```

const DIGEST_SIZE: usize = 3;
const ZERO: Option<u8> = Some(42);

fn compute_digest(text: &str) -> [u8; DIGEST_SIZE] {
    let mut digest = [ZERO.unwrap_or(0); DIGEST_SIZE];
    for (idx, &b) in text.as_bytes().iter().enumerate() {
        digest[idx % DIGEST_SIZE] = digest[idx % DIGEST_SIZE].wrapping_add(b);
    }
    digest
}

fn main() {
    let digest = compute_digest("Hello");
    println!("digest: {digest:?}");
}

```

[Rust RFC Book'a](#) göre bunlar kullanım sırasında satır içidir (inline).

Sadece const olarak işaretlenen fonksiyonlar derleme zamanında çağrılarak const değerler üretilebilir. Ancak const fonksiyonlar çalışma zamanında da çağrılabilir.

- const'un C++'ın constexpr'ına anlamsal olarak benzer davrandığını belirtin
- Çalışma zamanında değerlendirilen (evaluate) bir sabite (constant) ihtiyaç duyulması çok yaygın bir durum değildir, ancak statik kullanmaktan daha yararlı ve daha emniyetlidir.

10.5 static

Statik değişkenler programın tüm yürütmesi (execution) boyunca yaşayacak ve bu nedenle taşınmayacaklar:

```

static BANNER: &str = "RustOS 3.14'e Hoş Geldiniz";

fn main() {
    println!("{BANNER}");
}

```

[Rust RFC Kitabında](#) belirtildiği gibi, statik kullanımı satır içi (inline) özelliği vermez ve gerçek bir ilişkili bellek konumuna sahiptir. Bu, emniyetsiz ve gömülü kod için yararlıdır ve değişken, program yürütmesinin tamamı boyunca yaşar. Global kapsamlı (globally-scoped) bir değerın nesne kimliğine ihtiyaç duyması için bir nedeni olmadığında, genellikle const tercih edilir.

- statik, C++'daki değişebilir olan global değişkenlere benzer.
- `static`, `Mutex<T>` gibi iç değişebilirliğe sahip türlerin gerektirdiği şekilde bellekteki bir adres ve durumu nesneye kimlik olarak sağlar.

Daha Fazlasını Keşfedin

Çünkü `static` değişkenlere herhangi bir iş parçacığından erişilebildiğinden, bunların `Sync` olması gerekir. İç değişebilirlik `Mutex`, atomik veya benzer yöntemlerle mümkündür.

İş parçacığı için yerel (thread-local) veriler `std::thread_local` makrosu ile oluşturulabilir.

10.6 Tür Eş İsimleri (Type Aliases)

Bir tür eş ismi, başka bir tür için bir isim oluşturur. Her iki tür de birbirinin yerine kullanılabilir.

```
enum CarryableConcreteItem {
    Left,
    Right,
}
```

```
type Item = CarryableConcreteItem;
```

```
// Eş isimler (aliases) uzun ve karmaşık türlerde daha kullanışlıdır:
use std::cell::RefCell;
use std::sync::{Arc, RwLock};
type PlayerInventory = RwLock<Vec<Arc<RefCell<Item>>>>;
```

- **Bir yeni tür deseni (newtype)** genellikle farklı bir tür oluşturduğu için daha iyi bir seçenektir. `type InventoryCount = usize` yerine `struct InventoryCount(usize)`'i tercih edin.
- C programcılarının bunun, `typedef`'e benzer olduğunu anlayacaklardır.

10.7 Alıştırma: Asansör Olayları

Bir asansör kontrol sistemindeki bir olayı temsil etmek için bir veri yapısı oluşturacağız. Çeşitli olayları yapılandırmak için türleri ve fonksiyonları tanımlamak size kalmış. Türlerin `{:?}` ile biçimlendirilmesine izin vermek için `#[derive(Debug)]` kullanın.

Bu alıştırma yalnızca, `main`'in hatasız çalışması için veri yapıları oluşturmayı ve doldurmayı gerektirir. Kursun bir sonraki kısmı bu yapılardan veri almayı kapsayacaktır.

```
/// Asansör sisteminde kontrolörün tepki vermesi gereken bir olay.
enum Event {
    // TODO: gerekli değişkenleri (variant) ekle
}

/// Bir seyahat yönü.

enum Direction {
```

```

    Up,
    Down,
}

/// Araba verilen kata ulaşmış durumda.
fn car_arrived(floor: i32) -> Event {
    todo!()
}

/// Araba kapıları açılmış durumda.
fn car_door_opened() -> Event {
    todo!()
}

/// Araba kapıları kapanmış durumda.
fn car_door_closed() -> Event {
    todo!()
}

/// Verilen kattaki asansör lobisinde yön düğmesine basıldı.
fn lobby_call_button_pressed(floor: i32, dir: Direction) -> Event {
    todo!()
}

/// Asansör kabininde bir kat düğmesine basıldı.
fn car_floor_button_pressed(floor: i32) -> Event {
    todo!()
}

fn main() {
    println!(
        "Zemin kattaki bir yolcu yukarı düğmesine basmış durumda: {:?}" ,
        lobby_call_button_pressed(0, Direction::Up)
    );
    println!("Araba zemin kata ulaşmış durumda: {:?}", car_arrived(0));
    println!("Araba kapısı açıldı: {:?}", car_door_opened());
    println!(
        "Bir yolcu 3. katın düğmesine basmış durumda: {:?}",
        car_floor_button_pressed(3)
    );
    println!("Araba kapısı kapandı: {:?}", car_door_closed());
    println!("Araba 3. kata ulaşmış durumda: {:?}", car_arrived(3));
}

```

10.7.1 Çözüm

```

/// Asansör sisteminde kontrolörün tepki vermesi gereken bir olay.
enum Event {
    /// Bir düğmeye basıldı.
    ButtonPressed(Button),

```

```

    /// Araba verilen kata ulařmış durumda.
    CarArrived(Floor),

    /// Arabanın kapıları açık durumda.
    CarDoorOpened,

    /// Arabanın kapıları kapalı durumda.
    CarDoorClosed,
}

/// Bir kat tamsayı olarak temsil edilir.
type Floor = i32;

/// Bir seyahat yönü.

enum Direction {
    Up,
    Down,
}

/// Kullanıcının erişebileceđi bir düğme.
enum Button {
    /// Verilem katta asansör lobisinde bulunan bir düğme.
    LobbyCall(Direction, Floor),

    /// Arabanın içindeki bir kat düğmesi.
    CarFloor(Floor),
}

/// Araba verilen kata ulařmış durumda.
fn car_arrived(floor: i32) -> Event {
    Event::CarArrived(floor)
}

/// Araba kapıları açılmış durumda.
fn car_door_opened() -> Event {
    Event::CarDoorOpened
}

/// Araba kapıları kapanmış durumda.
fn car_door_closed() -> Event {
    Event::CarDoorClosed
}

/// Verilen kattaki asansör lobisinde yön düğmesine basıldı.
fn lobby_call_button_pressed(floor: i32, dir: Direction) -> Event {
    Event::ButtonPressed(Button::LobbyCall(dir, floor))
}

/// Asansör kabininde bir kat düğmesine basıldı.
fn car_floor_button_pressed(floor: i32) -> Event {

```

```

    Event::ButtonPressed(Button::CarFloor(floor))
}

fn main() {
    println!(
        "Zemin kattaki bir yolcu yukarı düğmesine basmış durumda: {:?}",
        lobby_call_button_pressed(0, Direction::Up)
    );
    println!("Araba zemin kata ulaşmış durumda: {:?}", car_arrived(0));
    println!("Araba kapısı açıldı: {:?}", car_door_opened());
    println!(
        "Bir yolcu 3. katın düğmesine basmış durumda: {:?}",
        car_floor_button_pressed(3)
    );
    println!("Araba kapısı kapandı: {:?}", car_door_closed());
    println!("Araba 3. kata ulaşmış durumda: {:?}", car_arrived(3));
}

```

Kısım III

Gün 2: Sabah

Bölüm 11

Welcome to Day 2

Now that we have seen a fair amount of Rust, today will focus on Rust's type system:

- Desen eşleştirme: yapıardan veri çıkarma.
- Methods: associating functions with types.
- Traits: behaviors shared by multiple types.
- Generics: parameterizing types on other types.
- Standard library types and traits: a tour of Rust's rich standard library.

Zamanlama (Schedule)

Bu oturum 10 dakikalık aralar dahil yaklaşık 2 saat 10 dakika sürmelidir. İçeriği:

Bölüm	Süre
Hoş Geldiniz	3 dakika
Desen Eşleştirme	1 saat
Metotlar ve Özellikler (Traits)	50 dakika

Bölüm 12

Desen Eşleştirme

Bu bölüm yaklaşık 1 saat sürmelidir. İçeriği:

Slayt	Süre
Değerleri Eşleştirmek	10 dakika
Yapıların (Struct) Çözümlemesi	4 dakika
Enum'ların (Struct) Çözümlemesi	4 dakika
Let'li Kontrol Akışı	10 dakika
Alıştırma: İfade Değerlendirmesi	30 dakika

12.1 Değerleri Eşleştirmek

The `match` keyword lets you match a value against one or more *patterns*. The comparisons are done from top to bottom and the first match wins.

The patterns can be simple values, similarly to `switch` in C and C++:

```
fn main() {
  let input = 'x';
  match input {
    'q' => println!("Quitting"),
    'a' | 's' | 'w' | 'd' => println!("Moving around"),
    '0'..'9' => println!("Number input"),
    key if key.is_lowercase() => println!("Lowercase: {key}"),
    _ => println!("Something else"),
  }
}
```

The `_` pattern is a wildcard pattern which matches any value. The expressions *must* be exhaustive, meaning that it covers every possibility, so `_` is often used as the final catch-all case.

Match can be used as an expression. Just like `if`, each match arm must have the same type. The type is the last expression of the block, if any. In the example above, the type is `()`.

A variable in the pattern (key in this example) will create a binding that can be used within the match arm.

A match guard causes the arm to match only if the condition is true.

Önemli Noktalar:

- You might point out how some specific characters are being used when in a pattern
 - | as an or
 - . . can expand as much as it needs to be
 - 1..=5 represents an inclusive range
 - _ is a wild card
- Match guards as a separate syntax feature are important and necessary when we wish to concisely express more complex ideas than patterns alone would allow.
- They are not the same as separate if expression inside of the match arm. An if expression inside of the branch block (after =>) happens after the match arm is selected. Failing the if condition inside of that block won't result in other arms of the original match expression being considered.
- The condition defined in the guard applies to every expression in a pattern with an |.

Daha Fazlasını Keşfedin

- Another piece of pattern syntax you can show students is the @ syntax which binds a part of a pattern to a variable. For example:

```
let opt = Some(123);
match opt {
  outer @ Some(inner) => {
    println!("outer: {outer:?}, inner: {inner}");
  }
  None => {}
}
```

In this example inner has the value 123 which it pulled from the Option via destructuring, outer captures the entire Some(inner) expression, so it contains the full Option::Some(123). This is rarely used but can be useful in more complex patterns.

12.2 Yapılar (Structs)

Like tuples, Struct can also be destructured by matching:

```
struct Foo {
  x: (u32, u32),
  y: u32,
}

fn main() {
  let foo = Foo { x: (1, 2), y: 3 };
  match foo {
```

```

    Foo { x: (1, b), y } => println!("x.0 = 1, b = {b}, y = {y}"),
    Foo { y: 2, x: i }   => println!("y = 2, x = {i:?}"),
    Foo { y, .. }       => println!("y = {y}, other fields were ignored"),
}
}

```

- Change the literal values in foo to match with the other patterns.
- Add a new field to Foo and make changes to the pattern as needed.
- The distinction between a capture and a constant expression can be hard to spot. Try changing the 2 in the second arm to a variable, and see that it subtly doesn't work. Change it to a const and see it working again.

12.3 Enumlar

Like tuples, enums can also be destructured by matching:

Patterns can also be used to bind variables to parts of your values. This is how you inspect the structure of your types. Let us start with a simple enum type:

```

enum Result {
    Ok(i32),
    Err(String),
}

fn divide_in_two(n: i32) -> Result {
    if n % 2 == 0 {
        Result::Ok(n / 2)
    } else {
        Result::Err(format!("cannot divide {n} into two equal parts"))
    }
}

fn main() {
    let n = 100;
    match divide_in_two(n) {
        Result::Ok(half) => println!("{n} divided in two is {half}"),
        Result::Err(msg)  => println!("sorry, an error happened: {msg}"),
    }
}

```

Here we have used the arms to *destructure* the Result value. In the first arm, half is bound to the value inside the Ok variant. In the second arm, msg is bound to the error message.

- The if/else expression is returning an enum that is later unpacked with a match.
- You can try adding a third variant to the enum definition and displaying the errors when running the code. Point out the places where your code is now inexhaustive and how the compiler tries to give you hints.
- The values in the enum variants can only be accessed after being pattern matched.
- Demonstrate what happens when the search is inexhaustive. Note the advantage the Rust compiler provides by confirming when all cases are handled.

12.4 Let'li Kontrol Akışı

Rust has a few control flow constructs which differ from other languages. They are used for pattern matching:

- `if let` ifadeleri
- `let else` ifadeleri
- `while let` ifadeleri

`if let` ifadeleri

The `if let expression` lets you execute different code depending on whether a value matches a pattern:

```
use std::time::Duration;

fn sleep_for(secs: f32) {
    if let Ok(duration) = Duration::try_from_secs_f32(secs) {
        std::thread::sleep(duration);
        println!("slept for {duration:?}");
    }
}

fn main() {
    sleep_for(-10.0);
    sleep_for(0.8);
}
```

`let else` ifadeleri

For the common case of matching a pattern and returning from the function, use `let else`. The "else" case must diverge (return, break, or panic - anything but falling off the end of the block).

```
fn hex_or_die_trying(maybe_string: Option<String>) -> Result<u32, String> {
    if let Some(s) = maybe_string {
        if let Some(first_byte_char) = s.chars().next() {
            if let Some(digit) = first_byte_char.to_digit(16) {
                Ok(digit)
            } else {
                return Err(String::from("not a hex digit"));
            }
        } else {
            return Err(String::from("got empty string"));
        }
    } else {
        return Err(String::from("got None"));
    }
}
```

```
fn main() {
    println!("result: {:?}", hex_or_die_trying(Some(String::from("foo"))));
}
```

Like with `if let`, there is a `while let` variant which repeatedly tests a value against a pattern:

```
fn main() {
    let mut name = String::from("Comprehensive Rust 🐛");
    while let Some(c) = name.pop() {
        println!("character: {c}");
    }
    // (There are more efficient ways to reverse a string!)
}
```

Here `String::pop` returns `Some(c)` until the string is empty, after which it will return `None`. The `while let` lets us keep iterating through all items.

if-let

- Unlike `match`, `if let` does not have to cover all branches. This can make it more concise than `match`.
- A common usage is handling `Some` values when working with `Option`.
- Unlike `match`, `if let` does not support guard clauses for pattern matching.

let-else

`if-lets` can pile up, as shown. The `let-else` construct supports flattening this nested code. Rewrite the awkward version for students, so they can see the transformation.

The rewritten version is:

```
fn hex_or_die_trying(maybe_string: Option<String>) -> Result<u32, String> {
    let Some(s) = maybe_string else {
        return Err(String::from("got None"));
    };

    let Some(first_byte_char) = s.chars().next() else {
        return Err(String::from("got empty string"));
    };

    let Some(digit) = first_byte_char.to_digit(16) else {
        return Err(String::from("not a hex digit"));
    };

    return Ok(digit);
}
```

while-let

- Point out that the `while let` loop will keep going as long as the value matches the pattern.

- You could rewrite the `while let` loop as an infinite loop with an `if` statement that breaks when there is no value to unwrap for `name.pop()`. The `while let` provides syntactic sugar for the above scenario.

12.5 Alıştırma: İfade Değerlendirmesi

Let's write a simple recursive evaluator for arithmetic expressions.

An example of a small arithmetic expression could be $10 + 20$, which evaluates to 30 . We can represent the expression as a tree:

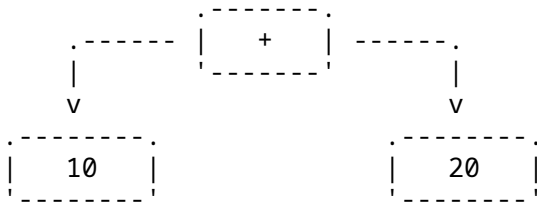

A bigger and more complex expression would be $(10 * 9) + ((3 - 4) * 5)$, which evaluate to 85 . We represent this as a much bigger tree:

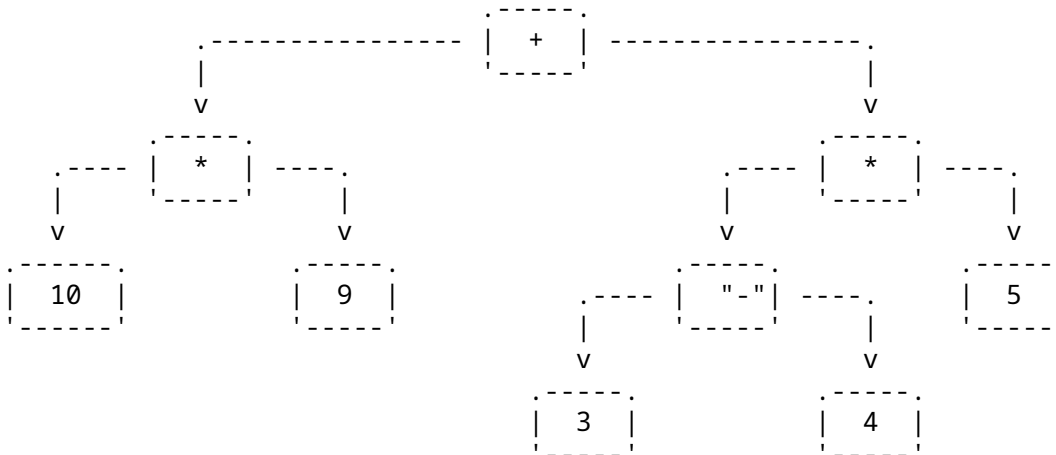

In code, we will represent the tree with two types:

```

/// An operation to perform on two subexpressions.
enum Operation {
    Add,
    Sub,
    Mul,
    Div,
}

/// An expression, in tree form.
enum Expression {
    /// An operation on two subexpressions.
    Op { op: Operation, left: Box<Expression>, right: Box<Expression> },

```



```

    /// A literal value
    Value(i64),
}

```

The Box type here is a smart pointer, and will be covered in detail later in the course. An expression can be "boxed" with `Box::new` as seen in the tests. To evaluate a boxed expression, use the deref operator (*) to "unbox" it: `eval(*boxed_expr)`.

Some expressions cannot be evaluated and will return an error. The standard `Result<Value, String>` type is an enum that represents either a successful value (`Ok(Value)`) or an error (`Err(String)`). We will cover this type in detail later.

Copy and paste the code into the Rust playground, and begin implementing `eval`. The final product should pass the tests. It may be helpful to use `todo!()` and get the tests to pass one-by-one. You can also skip a test temporarily with `#[ignore]`:

```

#[test]
#[ignore]
fn test_value() { .. }

/// An operation to perform on two subexpressions.
enum Operation {
    Add,
    Sub,
    Mul,
    Div,
}

/// An expression, in tree form.
enum Expression {
    /// An operation on two subexpressions.
    Op { op: Operation, left: Box<Expression>, right: Box<Expression> },

    /// A literal value
    Value(i64),
}

fn eval(e: Expression) -> Result<i64, String> {
    todo!()
}

fn test_value() {
    assert_eq!(eval(Expression::Value(19)), Ok(19));
}

fn test_sum() {
    assert_eq!(
        eval(Expression::Op {
            op: Operation::Add,
            left: Box::new(Expression::Value(10)),
            right: Box::new(Expression::Value(20)),
        }),
        Ok(30)
    );
}

```

```

    );
}

fn test_recursion() {
    let term1 = Expression::Op {
        op: Operation::Mul,
        left: Box::new(Expression::Value(10)),
        right: Box::new(Expression::Value(9)),
    };
    let term2 = Expression::Op {
        op: Operation::Mul,
        left: Box::new(Expression::Op {
            op: Operation::Sub,
            left: Box::new(Expression::Value(3)),
            right: Box::new(Expression::Value(4)),
        }),
        right: Box::new(Expression::Value(5)),
    };
    assert_eq!(
        eval(Expression::Op {
            op: Operation::Add,
            left: Box::new(term1),
            right: Box::new(term2),
        }),
        Ok(85)
    );
}

fn test_zeros() {
    assert_eq!(
        eval(Expression::Op {
            op: Operation::Add,
            left: Box::new(Expression::Value(0)),
            right: Box::new(Expression::Value(0))
        }),
        Ok(0)
    );
    assert_eq!(
        eval(Expression::Op {
            op: Operation::Mul,
            left: Box::new(Expression::Value(0)),
            right: Box::new(Expression::Value(0))
        }),
        Ok(0)
    );
    assert_eq!(
        eval(Expression::Op {
            op: Operation::Sub,
            left: Box::new(Expression::Value(0)),
            right: Box::new(Expression::Value(0))
        }),

```

```

        Ok(0)
    );
}

fn test_error() {
    assert_eq!(
        eval(Expression::Op {
            op: Operation::Div,
            left: Box::new(Expression::Value(99)),
            right: Box::new(Expression::Value(0)),
        }),
        Err(String::from("division by zero"))
    );
}

```

12.5.1 Çözüm

```

/// An operation to perform on two subexpressions.
enum Operation {
    Add,
    Sub,
    Mul,
    Div,
}

/// An expression, in tree form.
enum Expression {
    /// An operation on two subexpressions.
    Op { op: Operation, left: Box<Expression>, right: Box<Expression> },

    /// A literal value
    Value(i64),
}

fn eval(e: Expression) -> Result<i64, String> {
    match e {
        Expression::Op { op, left, right } => {
            let left = match eval(*left) {
                Ok(v) => v,
                Err(e) => return Err(e),
            };
            let right = match eval(*right) {
                Ok(v) => v,
                Err(e) => return Err(e),
            };
            Ok(match op {
                Operation::Add => left + right,
                Operation::Sub => left - right,
                Operation::Mul => left * right,
                Operation::Div => {
                    if right == 0 {

```

```

        return Err(String::from("division by zero"));
    } else {
        left / right
    }
    }
    })
}
Expression::Value(v) => Ok(v),
}
}

fn test_value() {
    assert_eq!(eval(Expression::Value(19)), Ok(19));
}

fn test_sum() {
    assert_eq!(
        eval(Expression::Op {
            op: Operation::Add,
            left: Box::new(Expression::Value(10)),
            right: Box::new(Expression::Value(20)),
        }),
        Ok(30)
    );
}

fn test_recursion() {
    let term1 = Expression::Op {
        op: Operation::Mul,
        left: Box::new(Expression::Value(10)),
        right: Box::new(Expression::Value(9)),
    };
    let term2 = Expression::Op {
        op: Operation::Mul,
        left: Box::new(Expression::Op {
            op: Operation::Sub,
            left: Box::new(Expression::Value(3)),
            right: Box::new(Expression::Value(4)),
        }),
        right: Box::new(Expression::Value(5)),
    };
    assert_eq!(
        eval(Expression::Op {
            op: Operation::Add,
            left: Box::new(term1),
            right: Box::new(term2),
        }),
        Ok(85)
    );
}
}

```

```

fn test_zeros() {
    assert_eq!(
        eval(Expression::Op {
            op: Operation::Add,
            left: Box::new(Expression::Value(0)),
            right: Box::new(Expression::Value(0))
        }),
        Ok(0)
    );
    assert_eq!(
        eval(Expression::Op {
            op: Operation::Mul,
            left: Box::new(Expression::Value(0)),
            right: Box::new(Expression::Value(0))
        }),
        Ok(0)
    );
    assert_eq!(
        eval(Expression::Op {
            op: Operation::Sub,
            left: Box::new(Expression::Value(0)),
            right: Box::new(Expression::Value(0))
        }),
        Ok(0)
    );
}

fn test_error() {
    assert_eq!(
        eval(Expression::Op {
            op: Operation::Div,
            left: Box::new(Expression::Value(99)),
            right: Box::new(Expression::Value(0))
        }),
        Err(String::from("division by zero"))
    );
}

fn main() {
    let expr = Expression::Op {
        op: Operation::Sub,
        left: Box::new(Expression::Value(20)),
        right: Box::new(Expression::Value(10)),
    };
    println!("expr: {expr:?}");
    println!("result: {:?}" , eval(expr));
}

```

Bölüm 13

Metotlar ve Özellikler (Traits)

Bu bölüm yaklaşık 50 dakika sürmelidir. İçeriği:

Slayt	Süre
Metotlar	10 dakika
Özellikler (Traits)	15 dakika
Türetme	3 dakika
Alıştırma: Genel Kaydedici	20 dakika

13.1 Metotlar

Rust allows you to associate functions with your new types. You do this with an `impl` block:

```
struct Race {
    name: String,
    laps: Vec<i32>,
}

impl Race {
    // No receiver, a static method
    fn new(name: &str) -> Self {
        Self { name: String::from(name), laps: Vec::new() }
    }

    // Exclusive borrowed read-write access to self
    fn add_lap(&mut self, lap: i32) {
        self.laps.push(lap);
    }

    // Shared and read-only borrowed access to self
    fn print_laps(&self) {
        println!("Recorded {} laps for {}:", self.laps.len(), self.name);
        for (idx, lap) in self.laps.iter().enumerate() {
            println!("Lap {idx}: {lap} sec");
        }
    }
}
```

```

    }
}

// Exclusive ownership of self (covered later)
fn finish(self) {
    let total: i32 = self.laps.iter().sum();
    println!("Race {} is finished, total lap time: {}", self.name, total);
}

fn main() {
    let mut race = Race::new("Monaco Grand Prix");
    race.add_lap(70);
    race.add_lap(68);
    race.print_laps();
    race.add_lap(71);
    race.print_laps();
    race.finish();
    // race.add_lap(42);
}

```

The `self` arguments specify the "receiver" - the object the method acts on. There are several common receivers for a method:

- `&self`: borrows the object from the caller using a shared and immutable reference. The object can be used again afterwards.
- `&mut self`: borrows the object from the caller using a unique and mutable reference. The object can be used again afterwards.
- `self`: takes ownership of the object and moves it away from the caller. The method becomes the owner of the object. The object will be dropped (deallocated) when the method returns, unless its ownership is explicitly transmitted. Complete ownership does not automatically mean mutability.
- `mut self`: same as above, but the method can mutate the object.
- No receiver: this becomes a static method on the struct. Typically used to create constructors which are called `new` by convention.

Önemli Noktalar:

- It can be helpful to introduce methods by comparing them to functions.
 - Methods are called on an instance of a type (such as a struct or enum), the first parameter represents the instance as `self`.
 - Developers may choose to use methods to take advantage of method receiver syntax and to help keep them more organized. By using methods we can keep all the implementation code in one predictable place.
- Point out the use of the keyword `self`, a method receiver.
 - Show that it is an abbreviated term for `self`: `Self` and perhaps show how the struct name could also be used.
 - Explain that `Self` is a type alias for the type the `impl` block is in and can be used elsewhere in the block.
 - Note how `self` is used like other structs and dot notation can be used to refer to individual fields.
 - This might be a good time to demonstrate how the `&self` differs from `self` by trying to run `finish` twice.

- Beyond variants on `self`, there are also **special wrapper types** allowed to be receiver types, such as `Box<Self>`.

13.2 Özellikler (Traits)

Rust lets you abstract over types with traits. They're similar to interfaces:

```
trait Pet {
    /// Return a sentence from this pet.
    fn talk(&self) -> String;

    /// Print a string to the terminal greeting this pet.
    fn greet(&self);
}
```

- A trait defines a number of methods that types must have in order to implement the trait.
- In the "Generics" segment, next, we will see how to build functionality that is generic over all types implementing a trait.

13.2.1 Özelliklerin (Traits) Gerçekleştirimi

```
trait Pet {
    fn talk(&self) -> String;

    fn greet(&self) {
        println!("Oh you're a cutie! What's your name? {}", self.talk());
    }
}

struct Dog {
    name: String,
    age: i8,
}

impl Pet for Dog {
    fn talk(&self) -> String {
        format!("Woof, my name is {}!", self.name)
    }
}

fn main() {
    let fido = Dog { name: String::from("Fido"), age: 5 };
    fido.greet();
}
```

- To implement Trait for Type, you use an `impl Trait for Type { .. }` block.
- Unlike Go interfaces, just having matching methods is not enough: a `Cat` type with a `talk()` method would not automatically satisfy `Pet` unless it is in an `impl Pet` block.

- Traits may provide default implementations of some methods. Default implementations can rely on all the methods of the trait. In this case, `greet` is provided, and relies on `talk`.

13.2.2 Üstözellikler (Supertraits)

A trait can require that types implementing it also implement other traits, called *supertraits*. Here, any type implementing `Pet` must implement `Animal`.

```
trait Animal {
    fn leg_count(&self) -> u32;
}

trait Pet: Animal {
    fn name(&self) -> String;
}

struct Dog(String);

impl Animal for Dog {
    fn leg_count(&self) -> u32 {
        4
    }
}

impl Pet for Dog {
    fn name(&self) -> String {
        self.0.clone()
    }
}

fn main() {
    let puppy = Dog(String::from("Rex"));
    println!("{}", puppy.name(), puppy.leg_count());
}
```

This is sometimes called "trait inheritance" but students should not expect this to behave like OO inheritance. It just specifies an additional requirement on implementations of a trait.

13.2.3 İlişkili Türler

Associated types are placeholder types which are supplied by the trait implementation.

```
struct Meters(i32);
struct MetersSquared(i32);

trait Multiply {
    type Output;
    fn multiply(&self, other: &Self) -> Self::Output;
}

impl Multiply for Meters {
```

```

    type Output = MetersSquared;
    fn multiply(&self, other: &Self) -> Self::Output {
        MetersSquared(self.0 * other.0)
    }
}

fn main() {
    println!("{:?}", Meters(10).multiply(&Meters(20)));
}

```

- Associated types are sometimes also called "output types". The key observation is that the implementer, not the caller, chooses this type.
- Many standard library traits have associated types, including arithmetic operators and Iterator.

13.3 Türetme

Supported traits can be automatically implemented for your custom types, as follows:

```

struct Player {
    name: String,
    strength: u8,
    hit_points: u8,
}

fn main() {
    let p1 = Player::default(); // Default trait adds `default` constructor.
    let mut p2 = p1.clone(); // Clone trait adds `clone` method.
    p2.name = String::from("EldurScrollz");
    // Debug trait adds support for printing with `{:?}`.
    println!("{p1:?} vs. {p2:?}");
}

```

Derivation is implemented with macros, and many crates provide useful derive macros to add useful functionality. For example, `serde` can derive serialization support for a struct using `#[derive(Deserialize)]`.

13.4 Alıştırma: Kaydedici Özellik

Let's design a simple logging utility, using a trait `Logger` with a `log` method. Code which might log its progress can then take an `&impl Logger`. In testing, this might put messages in the test logfile, while in a production build it would send messages to a log server.

However, the `StdoutLogger` given below logs all messages, regardless of verbosity. Your task is to write a `VerbosityFilter` type that will ignore messages above a maximum verbosity.

This is a common pattern: a struct wrapping a trait implementation and implementing that same trait, adding behavior in the process. What other kinds of wrappers might be useful in a logging utility?

```

pub trait Logger {
    /// Log a message at the given verbosity level.
    fn log(&self, verbosity: u8, message: &str);
}

struct StdoutLogger;

impl Logger for StdoutLogger {
    fn log(&self, verbosity: u8, message: &str) {
        println!("verbosity={verbosity}: {message}");
    }
}

// TODO: Define and implement `VerbosityFilter`.

fn main() {
    let logger = VerbosityFilter { max_verbosity: 3, inner: StdoutLogger };
    logger.log(5, "FYI");
    logger.log(2, "Uhoh");
}

```

13.4.1 Çözüm

```

pub trait Logger {
    /// Log a message at the given verbosity level.
    fn log(&self, verbosity: u8, message: &str);
}

struct StdoutLogger;

impl Logger for StdoutLogger {
    fn log(&self, verbosity: u8, message: &str) {
        println!("verbosity={verbosity}: {message}");
    }
}

/// Only log messages up to the given verbosity level.
struct VerbosityFilter {
    max_verbosity: u8,
    inner: StdoutLogger,
}

impl Logger for VerbosityFilter {
    fn log(&self, verbosity: u8, message: &str) {
        if verbosity <= self.max_verbosity {
            self.inner.log(verbosity, message);
        }
    }
}

fn main() {

```

```
let logger = VerbosityFilter { max_verbosity: 3, inner: StdoutLogger };  
logger.log(5, "FYI");  
logger.log(2, "Uhoh");  
}
```

Kısım IV

Gün 2: Öğleden Sonra

Bölüm 14

Tekrar Hoş Geldiniz

Bu oturum 10 dakikalık aralar dahil yaklaşık 2 saat 15 dakika sürmelidir. İçeriği:

Bölüm	Süre
Jenerikler	45 dakika
Standart Kütüphane Türleri	1 saat
Standart Kütüphanedeki Özellikler (Traits)	1 saat 10 dakika

Bölüm 15

Jenerikler

Bu bölüm yaklaşık 45 dakika sürmelidir. İçeriği:

Slayt	Süre
Jenerik Fonksiyonlar	5 dakika
Jenerik Veri Türleri	10 dakika
Özellik (Trait) Sınırları	10 dakika
impl Trait	5 dakika
dyn Trait	5 dakika
Alıştırma: Jenerik min	10 dakika

15.1 Jenerik Fonksiyonlar

Rust supports generics, which lets you abstract algorithms or data structures (such as sorting or a binary tree) over the types used or stored.

```
/// Pick `even` or `odd` depending on the value of `n`.
fn pick<T>(n: i32, even: T, odd: T) -> T {
    if n % 2 == 0 {
        even
    } else {
        odd
    }
}

fn main() {
    println!("picked a number: {:?}", pick(97, 222, 333));
    println!("picked a string: {:?}", pick(28, "dog", "cat"));
}
```

- Rust infers a type for T based on the types of the arguments and return value.
- In this example we only use the primitive types `i32` and `&str` for T, but we can use any type here, including user-defined types:

```

struct Foo {
    val: u8,
}

```

```

pick(123, Foo { val: 7 }, Foo { val: 456 });

```

- This is similar to C++ templates, but Rust partially compiles the generic function immediately, so that function must be valid for all types matching the constraints. For example, try modifying `pick` to return `even + odd` if `n == 0`. Even if only the `pick` instantiation with integers is used, Rust still considers it invalid. C++ would let you do this.
- Generic code is turned into non-generic code based on the call sites. This is a zero-cost abstraction: you get exactly the same result as if you had hand-coded the data structures without the abstraction.

15.2 Jenerik Veri Türleri

You can use generics to abstract over the concrete field type:

```

struct Point<T> {
    x: T,
    y: T,
}

```

```

impl<T> Point<T> {
    fn coords(&self) -> (&T, &T) {
        (&self.x, &self.y)
    }

    fn set_x(&mut self, x: T) {
        self.x = x;
    }
}

```

```

fn main() {
    let integer = Point { x: 5, y: 10 };
    let float = Point { x: 1.0, y: 4.0 };
    println!("{integer:?} and {float:?}");
    println!("coords: {:?}", integer.coords());
}

```

- Q: Why `T` is specified twice in `impl<T> Point<T> {}`? Isn't that redundant?
 - This is because it is a generic implementation section for generic type. They are independently generic.
 - It means these methods are defined for any `T`.
 - It is possible to write `impl Point<u32> { .. }`.
 - * `Point` is still generic and you can use `Point<f64>`, but methods in this block will only be available for `Point<u32>`.
- Try declaring a new variable `let p = Point { x: 5, y: 10.0 };`. Update the code to allow points that have elements of different types, by using two type variables, e.g., `T`

and U.

15.3 Jenerik Özellikler (Traits)

Traits can also be generic, just like types and functions. A trait's parameters get concrete types when it is used.

```
struct Foo(String);

impl From<u32> for Foo {
    fn from(from: u32) -> Foo {
        Foo(format!("Converted from integer: {from}"))
    }
}

impl From<bool> for Foo {
    fn from(from: bool) -> Foo {
        Foo(format!("Converted from bool: {from}"))
    }
}

fn main() {
    let from_int = Foo::from(123);
    let from_bool = Foo::from(true);
    println!("{from_int:?}, {from_bool:?}");
}
```

- The From trait will be covered later in the course, but its [definition in the std docs](#) is simple.
- Implementations of the trait do not need to cover all possible type parameters. Here, `Foo::from("hello")` would not compile because there is no `From<&str>` implementation for `Foo`.
- Generic traits take types as "input", while associated types are a kind of "output" type. A trait can have multiple implementations for different input types.
- In fact, Rust requires that at most one implementation of a trait match for any type `T`. Unlike some other languages, Rust has no heuristic for choosing the "most specific" match. There is work on adding this support, called [specialization](#).

15.4 Özellik (Trait) Sınırları

When working with generics, you often want to require the types to implement some trait, so that you can call this trait's methods.

You can do this with `T: Trait`:

```
fn duplicate<T: Clone>(a: T) -> (T, T) {
    (a.clone(), a.clone())
}
```

```
// struct NotCloneable;

fn main() {
    let foo = String::from("foo");
    let pair = duplicate(foo);
    println!("{pair:?}");
}
```

- Try making a NonCloneable and passing it to duplicate.
- When multiple traits are necessary, use + to join them.
- Show a where clause, students will encounter it when reading code.

```
fn duplicate<T>(a: T) -> (T, T)
where
    T: Clone,
{
    (a.clone(), a.clone())
}
```

- It declutters the function signature if you have many parameters.
- It has additional features making it more powerful.
 - * If someone asks, the extra feature is that the type on the left of ":" can be arbitrary, like Option<T>.
- Note that Rust does not (yet) support specialization. For example, given the original duplicate, it is invalid to add a specialized duplicate(a: u32).

15.5 impl Trait

Similar to trait bounds, an `impl Trait` syntax can be used in function arguments and return values:

```
// Syntactic sugar for:
// fn add_42_millions<T: Into<i32>>(x: T) -> i32 {
fn add_42_millions(x: impl Into<i32>) -> i32 {
    x.into() + 42_000_000
}

fn pair_of(x: u32) -> impl std::fmt::Debug {
    (x + 1, x - 1)
}

fn main() {
    let many = add_42_millions(42_i8);
    println!("{many}");
    let many_more = add_42_millions(10_000_000);
    println!("{many_more}");
    let debuggable = pair_of(27);
    println!("debuggable: {debuggable:?}");
}
```

`impl Trait` allows you to work with types which you cannot name. The meaning of `impl Trait` is a bit different in the different positions.

- For a parameter, `impl Trait` is like an anonymous generic parameter with a trait bound.
- For a return type, it means that the return type is some concrete type that implements the trait, without naming the type. This can be useful when you don't want to expose the concrete type in a public API.

Inference is hard in return position. A function returning `impl Foo` picks the concrete type it returns, without writing it out in the source. A function returning a generic type like `collect() -> B` can return any type satisfying `B`, and the caller may need to choose one, such as with `let x: Vec<_> = foo.collect()` or with the turbofish, `foo.collect::.`

What is the type of `debuggable`? Try `let debuggable: () = ..` to see what the error message shows.

15.6 dyn Trait

In addition to using traits for static dispatch via generics, Rust also supports using them for type-erased, dynamic dispatch via trait objects:

```
struct Dog {
    name: String,
    age: i8,
}
struct Cat {
    lives: i8,
}

trait Pet {
    fn talk(&self) -> String;
}

impl Pet for Dog {
    fn talk(&self) -> String {
        format!("Woof, my name is {}!", self.name)
    }
}

impl Pet for Cat {
    fn talk(&self) -> String {
        String::from("Miau!")
    }
}

// Uses generics and static dispatch.
fn generic(pet: &impl Pet) {
    println!("Merhaba, nasılsın? {}", pet.talk());
}
```

```

// Uses type-erasure and dynamic dispatch.
fn dynamic(pet: &dyn Pet) {
    println!("Merhaba, nasılsın? {}", pet.talk());
}

fn main() {
    let cat = Cat { lives: 9 };
    let dog = Dog { name: String::from("Fido"), age: 5 };

    generic(&cat);
    generic(&dog);

    dynamic(&cat);
    dynamic(&dog);
}

```

- Generics, including `impl Trait`, use monomorphization to create a specialized instance of the function for each different type that the generic is instantiated with. This means that calling a trait method from within a generic function still uses static dispatch, as the compiler has full type information and can resolve which type's trait implementation to use.
- When using `dyn Trait`, it instead uses dynamic dispatch through a **virtual method table** (vtable). This means that there's a single version of `fn dynamic` that is used regardless of what type of `Pet` is passed in.
- When using `dyn Trait`, the trait object needs to be behind some kind of indirection. In this case it's a reference, though smart pointer types like `Box` can also be used (this will be demonstrated on day 3).
- At runtime, a `&dyn Pet` is represented as a "fat pointer", i.e. a pair of two pointers: One pointer points to the concrete object that implements `Pet`, and the other points to the vtable for the trait implementation for that type. When calling the `talk` method on `&dyn Pet` the compiler looks up the function pointer for `talk` in the vtable and then invokes the function, passing the pointer to the `Dog` or `Cat` into that function. The compiler doesn't need to know the concrete type of the `Pet` in order to do this.
- A `dyn Trait` is considered to be "type-erased", because we no longer have compile-time knowledge of what the concrete type is.

15.7 Alıştırma: Jenerik min

In this short exercise, you will implement a generic `min` function that determines the minimum of two values, using the `Ord` trait.

```

use std::cmp::Ordering;

// TODO: implement the `min` function used in `main`.

fn main() {
    assert_eq!(min(0, 10), 0);
    assert_eq!(min(500, 123), 123);
}

```

```

    assert_eq!(min('a', 'z'), 'a');
    assert_eq!(min('7', '1'), '1');

    assert_eq!(min("merhaba", "goodbye"), "goodbye");
    assert_eq!(min("bat", "armadillo"), "armadillo");
}

```

- Show students the `Ord` trait and `Ordering` enum.

15.7.1 Çözüm

```

use std::cmp::Ordering;

```

```

fn min<T: Ord>(l: T, r: T) -> T {
    match l.cmp(&r) {
        Ordering::Less | Ordering::Equal => l,
        Ordering::Greater => r,
    }
}

```

```

fn main() {
    assert_eq!(min(0, 10), 0);
    assert_eq!(min(500, 123), 123);

    assert_eq!(min('a', 'z'), 'a');
    assert_eq!(min('7', '1'), '1');

    assert_eq!(min("merhaba", "goodbye"), "goodbye");
    assert_eq!(min("bat", "armadillo"), "armadillo");
}

```

Bölüm 16

Standart Kütüphane Türleri

Bu bölüm yaklaşık 1 saat sürmelidir. İçeriği:

Slayt	Süre
Standart Kütüphane	3 dakika
Dokümantasyon	5 dakika
Option	10 dakika
Result	5 dakika
String	5 dakika
Vec	5 dakika
HashMap	5 dakika
Alıştırma: Sayıcı	20 dakika

For each of the slides in this section, spend some time reviewing the documentation pages, highlighting some of the more common methods.

16.1 Standart Kütüphane

Rust comes with a standard library which helps establish a set of common types used by Rust libraries and programs. This way, two libraries can work together smoothly because they both use the same `String` type.

In fact, Rust contains several layers of the Standard Library: `core`, `alloc` and `std`.

- `core` includes the most basic types and functions that don't depend on `libc`, allocator or even the presence of an operating system.
- `alloc` includes types which require a global heap allocator, such as `Vec`, `Box` and `Arc`.
- Embedded Rust applications often only use `core`, and sometimes `alloc`.

16.2 Dokümantasyon

Rust comes with extensive documentation. For example:

- All of the details about [loops](#).
- Primitive types like [u8](#).
- Standard library types like [Option](#) or [BinaryHeap](#).

Use `rustup doc --std` or <https://std.rs> to view the documentation.

In fact, you can document your own code:

```
/// Determine whether the first argument is divisible by the second argument.
///
/// If the second argument is zero, the result is false.
fn is_divisible_by(lhs: u32, rhs: u32) -> bool {
    if rhs == 0 {
        return false;
    }
    lhs % rhs == 0
}
```

The contents are treated as Markdown. All published Rust library crates are automatically documented at docs.rs using the [rustdoc](#) tool. It is idiomatic to document all public items in an API using this pattern.

To document an item from inside the item (such as inside a module), use `///!` or `/*! ... */`, called "inner doc comments":

```
///! This module contains functionality relating to divisibility of integers.
```

- Show students the generated docs for the `rand` crate at <https://docs.rs/rand>.

16.3 Option

We have already seen some use of `Option<T>`. It stores either a value of type `T` or nothing. For example, `String::find` returns an `Option<usize>`.

```
fn main() {
    let name = "Löwe 老虎 Léopard Gepardi";
    let mut position: Option<usize> = name.find('é');
    println!("find returned {position:?}");
    assert_eq!(position.unwrap(), 14);
    position = name.find('Z');
    println!("find returned {position:?}");
    assert_eq!(position.expect("Character not found"), 0);
}
```

- `Option` is widely used, not just in the standard library.
- `unwrap` will return the value in an `Option`, or panic. `expect` is similar but takes an error message.
 - You can panic on `None`, but you can't "accidentally" forget to check for `None`.
 - It's common to `unwrap/expect` all over the place when hacking something together, but production code typically handles `None` in a nicer fashion.
- The "niche optimization" means that `Option<T>` often has the same size in memory as `T`, if there is some representation that is not a valid value of `T`. For example, a reference

cannot be NULL, so `Option<&T>` automatically uses NULL to represent the None variant, and thus can be stored in the same memory as `&T`.

16.4 Result

`Result` is similar to `Option`, but indicates the success or failure of an operation, each with a different enum variant. It is generic: `Result<T, E>` where `T` is used in the `Ok` variant and `E` appears in the `Err` variant.

```
use std::fs::File;
use std::io::Read;

fn main() {
    let file: Result<File, std::io::Error> = File::open("diary.txt");
    match file {
        Ok(mut file) => {
            let mut contents = String::new();
            if let Ok(bytes) = file.read_to_string(&mut contents) {
                println!("Dear diary: {contents} ({} bytes)", bytes);
            } else {
                println!("Could not read file content");
            }
        }
        Err(err) => {
            println!("The diary could not be opened: {err}");
        }
    }
}
```

- As with `Option`, the successful value sits inside of `Result`, forcing the developer to explicitly extract it. This encourages error checking. In the case where an error should never happen, `unwrap()` or `expect()` can be called, and this is a signal of the developer intent too.
- `Result` documentation is a recommended read. Not during the course, but it is worth mentioning. It contains a lot of convenience methods and functions that help functional-style programming.
- `Result` is the standard type to implement error handling as we will see on Day 4.

16.5 String

`String` is a growable UTF-8 encoded string:

```
fn main() {
    let mut s1 = String::new();
    s1.push_str("Merhaba");
    println!("s1: len = {}, capacity = {}", s1.len(), s1.capacity());

    let mut s2 = String::with_capacity(s1.len() + 1);
    s2.push_str(&s1);
    s2.push('!');
}
```



```
println!("s2: len = {}, capacity = {}", s2.len(), s2.capacity());

let s3 = String::from("🇨🇭");
println!("s3: len = {}, number of chars = {}", s3.len(), s3.chars().count());
}
```

String implements `Deref<Target = str>`, which means that you can call all `str` methods on a `String`.

- `String::new` returns a new empty string, use `String::with_capacity` when you know how much data you want to push to the string.
- `String::len` returns the size of the `String` in bytes (which can be different from its length in characters).
- `String::chars` returns an iterator over the actual characters. Note that a `char` can be different from what a human will consider a "character" due to **grapheme clusters**.
- When people refer to strings they could either be talking about `&str` or `String`.
- When a type implements `Deref<Target = T>`, the compiler will let you transparently call methods from `T`.
 - We haven't discussed the `Deref` trait yet, so at this point this mostly explains the structure of the sidebar in the documentation.
 - `String` implements `Deref<Target = str>` which transparently gives it access to `str`'s methods.
 - Write and compare `let s3 = s1.deref();` and `let s3 = &*s1;`
- `String` is implemented as a wrapper around a vector of bytes, many of the operations you see supported on vectors are also supported on `String`, but with some extra guarantees.
- Compare the different ways to index a `String`:
 - To a character by using `s3.chars().nth(i).unwrap()` where `i` is in-bound, out-of-bounds.
 - To a substring by using `s3[0..4]`, where that slice is on character boundaries or not.
- Many types can be converted to a string with the `to_string` method. This trait is automatically implemented for all types that implement `Display`, so anything that can be formatted can also be converted to a string.

16.6 Vec

`Vec` is the standard resizable heap-allocated buffer:

```
fn main() {
    let mut v1 = Vec::new();
    v1.push(42);
    println!("v1: len = {}, capacity = {}", v1.len(), v1.capacity());

    let mut v2 = Vec::with_capacity(v1.len() + 1);
    v2.extend(v1.iter());
    v2.push(9999);
    println!("v2: len = {}, capacity = {}", v2.len(), v2.capacity());

    // Canonical macro to initialize a vector with elements.
    let mut v3 = vec![0, 0, 1, 2, 3, 4];
}
```

```

// Retain only the even elements.
v3.retain(|x| x % 2 == 0);
println!("{v3:?}");

// Remove consecutive duplicates.
v3.dedup();
println!("{v3:?}");
}

```

Vec implements `Deref<Target = [T]>`, which means that you can call slice methods on a Vec.

- Vec is a type of collection, along with String and HashMap. The data it contains is stored on the heap. This means the amount of data doesn't need to be known at compile time. It can grow or shrink at runtime.
- Notice how `Vec<T>` is a generic type too, but you don't have to specify T explicitly. As always with Rust type inference, the T was established during the first push call.
- `vec![...]` is a canonical macro to use instead of `Vec::new()` and it supports adding initial elements to the vector.
- To index the vector you use `[]`, but they will panic if out of bounds. Alternatively, using `get` will return an `Option`. The `pop` function will remove the last element.
- Slices are covered on day 3. For now, students only need to know that a value of type Vec gives access to all of the documented slice methods, too.

16.7 HashMap

Standard hash map with protection against HashDoS attacks:

```

use std::collections::HashMap;

fn main() {
    let mut page_counts = HashMap::new();
    page_counts.insert("Adventures of Huckleberry Finn", 207);
    page_counts.insert("Grimms' Fairy Tales", 751);
    page_counts.insert("Pride and Prejudice", 303);

    if !page_counts.contains_key("Les Misérables") {
        println!(
            "We know about {} books, but not Les Misérables.",
            page_counts.len()
        );
    }

    for book in ["Pride and Prejudice", "Alice's Adventure in Wonderland"] {
        match page_counts.get(book) {
            Some(count) => println!("{book}: {count} pages"),
            None => println!("{book} is unknown."),
        }
    }
}

```

```

// Use the .entry() method to insert a value if nothing is found.
for book in ["Pride and Prejudice", "Alice's Adventure in Wonderland"] {
    let page_count: &mut i32 = page_counts.entry(book).or_insert(0);
    *page_count += 1;
}

println!("{page_counts:#?}");
}

```

- HashMap is not defined in the prelude and needs to be brought into scope.
- Try the following lines of code. The first line will see if a book is in the hashmap and if not return an alternative value. The second line will insert the alternative value in the hashmap if the book is not found.

```

let pc1 = page_counts
    .get("Harry Potter and the Sorcerer's Stone")
    .unwrap_or(&336);
let pc2 = page_counts
    .entry("The Hunger Games")
    .or_insert(374);

```

- Unlike `vec!`, there is unfortunately no standard `hashmap!` macro.
 - Although, since Rust 1.56, `HashMap` implements `From<[(K, V); N]>`, which allows us to easily initialize a hash map from a literal array:

```

let page_counts = HashMap::from([
    ("Harry Potter and the Sorcerer's Stone".to_string(), 336),
    ("The Hunger Games".to_string(), 374),
]);

```

- Alternatively `HashMap` can be built from any `Iterator` which yields key-value tuples.
- This type has several "method-specific" return types, such as `std::collections::hash_map::Keys`. These types often appear in searches of the Rust docs. Show students the docs for this type, and the helpful link back to the `keys` method.

16.8 Alıştırma: Sayıcı

In this exercise you will take a very simple data structure and make it generic. It uses a `std::collections::HashMap` to keep track of which values have been seen and how many times each one has appeared.

The initial version of `Counter` is hard coded to only work for `u32` values. Make the struct and its methods generic over the type of value being tracked, that way `Counter` can track any type of value.

If you finish early, try using the `entry` method to halve the number of hash lookups required to implement the `count` method.

```
use std::collections::HashMap;
```

```

/// Counter counts the number of times each value of type T has been seen.
struct Counter {

```

```

    values: HashMap<u32, u64>,
}

impl Counter {
    /// Create a new Counter.
    fn new() -> Self {
        Counter {
            values: HashMap::new(),
        }
    }

    /// Count an occurrence of the given value.
    fn count(&mut self, value: u32) {
        if self.values.contains_key(&value) {
            *self.values.get_mut(&value).unwrap() += 1;
        } else {
            self.values.insert(value, 1);
        }
    }

    /// Return the number of times the given value has been seen.
    fn times_seen(&self, value: u32) -> u64 {
        self.values.get(&value).copied().unwrap_or_default()
    }
}

fn main() {
    let mut ctr = Counter::new();
    ctr.count(13);
    ctr.count(14);
    ctr.count(16);
    ctr.count(14);
    ctr.count(14);
    ctr.count(11);

    for i in 10..20 {
        println!("saw {} values equal to {}", ctr.times_seen(i), i);
    }

    let mut strctr = Counter::new();
    strctr.count("apple");
    strctr.count("orange");
    strctr.count("apple");
    println!("got {} apples", strctr.times_seen("apple"));
}

```

16.8.1 Çözüm

```

use std::collections::HashMap;
use std::hash::Hash;

```

```

/// Counter counts the number of times each value of type T has been seen.
struct Counter<T> {
    values: HashMap<T, u64>,
}

impl<T: Eq + Hash> Counter<T> {
    /// Create a new Counter.
    fn new() -> Self {
        Counter { values: HashMap::new() }
    }

    /// Count an occurrence of the given value.
    fn count(&mut self, value: T) {
        *self.values.entry(value).or_default() += 1;
    }

    /// Return the number of times the given value has been seen.
    fn times_seen(&self, value: T) -> u64 {
        self.values.get(&value).copied().unwrap_or_default()
    }
}

fn main() {
    let mut ctr = Counter::new();
    ctr.count(13);
    ctr.count(14);
    ctr.count(16);
    ctr.count(14);
    ctr.count(14);
    ctr.count(11);

    for i in 10..20 {
        println!("saw {} values equal to {}", ctr.times_seen(i), i);
    }

    let mut strctr = Counter::new();
    strctr.count("apple");
    strctr.count("orange");
    strctr.count("apple");
    println!("got {} apples", strctr.times_seen("apple"));
}

```

Bölüm 17

Standart Kütüphanedeki Özellikler (Traits)

Bu bölüm yaklaşık 1 saat 10 dakika sürmelidir. İçeriği:

Slayt	Süre
Karşılaştırmalar	5 dakika
Operatörler	5 dakika
From ve Into	5 dakika
Tür Çevirimi	5 dakika
Read ve Write	5 dakika
Default, yapı (struct) güncelleme sözdizimi	5 dakika
Çevreleyiciler (Closures)	10 dakika
Alıştırma: ROT13	30 dakika

As with the standard-library types, spend time reviewing the documentation for each trait. This section is long. Take a break midway through.

17.1 Karşılaştırmalar

These traits support comparisons between values. All traits can be derived for types containing fields that implement these traits.

PartialEq and Eq

PartialEq is a partial equivalence relation, with required method `eq` and provided method `ne`. The `==` and `!=` operators will call these methods.

```
struct Key {  
    id: u32,  
    metadata: Option<String>,  
}
```

```

impl PartialEq for Key {
    fn eq(&self, other: &Self) -> bool {
        self.id == other.id
    }
}

```

Eq is a full equivalence relation (reflexive, symmetric, and transitive) and implies PartialEq. Functions that require full equivalence will use Eq as a trait bound.

PartialOrd and Ord

PartialOrd defines a partial ordering, with a partial_cmp method. It is used to implement the <, <=, >=, and > operators.

```

use std::cmp::Ordering;
struct Citation {
    author: String,
    year: u32,
}
impl PartialOrd for Citation {
    fn partial_cmp(&self, other: &Self) -> Option<Ordering> {
        match self.author.partial_cmp(&other.author) {
            Some(Ordering::Equal) => self.year.partial_cmp(&other.year),
            author_ord => author_ord,
        }
    }
}

```

Ord is a total ordering, with cmp returning Ordering.

PartialEq can be implemented between different types, but Eq cannot, because it is reflexive:

```

struct Key {
    id: u32,
    metadata: Option<String>,
}
impl PartialEq<u32> for Key {
    fn eq(&self, other: &u32) -> bool {
        self.id == *other
    }
}

```

In practice, it's common to derive these traits, but uncommon to implement them.

17.2 Operatörler

Operator overloading is implemented via traits in `std::ops`:

```

struct Point {
    x: i32,
    y: i32,
}

```

```

impl std::ops::Add for Point {
    type Output = Self;

    fn add(self, other: Self) -> Self {
        Self { x: self.x + other.x, y: self.y + other.y }
    }
}

fn main() {
    let p1 = Point { x: 10, y: 20 };
    let p2 = Point { x: 100, y: 200 };
    println!("{p1:?} + {p2:?} = {:?}", p1 + p2);
}

```

Discussion points:

- You could implement Add for &Point. In which situations is that useful?
 - Answer: Add::add consumes self. If type T for which you are overloading the operator is not Copy, you should consider overloading the operator for &T as well. This avoids unnecessary cloning on the call site.
- Why is Output an associated type? Could it be made a type parameter of the method?
 - Short answer: Function type parameters are controlled by the caller, but associated types (like Output) are controlled by the implementer of a trait.
- You could implement Add for two different types, e.g. impl Add<(i32, i32)> for Point would add a tuple to a Point.

The Not trait (! operator) is notable because it does not "boolify" like the same operator in C-family languages; instead, for integer types it negates each bit of the number, which arithmetically is equivalent to subtracting it from -1: !5 == -6.

17.3 From ve Into

Types implement **From** and **Into** to facilitate type conversions. Unlike as, these traits correspond to lossless, infallible conversions.

```

fn main() {
    let s = String::from("merhaba");
    let addr = std::net::Ipv4Addr::from([127, 0, 0, 1]);
    let one = i16::from(true);
    let bigger = i32::from(123_i16);
    println!("{s}, {addr}, {one}, {bigger}");
}

```

Into is automatically implemented when **From** is implemented:

```

fn main() {
    let s: String = "merhaba".into();
    let addr: std::net::Ipv4Addr = [127, 0, 0, 1].into();
    let one: i16 = true.into();
    let bigger: i32 = 123_i16.into();
    println!("{s}, {addr}, {one}, {bigger}");
}

```

- That's why it is common to only implement `From`, as your type will get `Into` implementation too.
- When declaring a function argument input type like "anything that can be converted into a `String`", the rule is opposite, you should use `Into`. Your function will accept types that implement `From` and those that *only* implement `Into`.

17.4 Tür Çevirimi

Rust has no *implicit* type conversions, but does support explicit casts with `as`. These generally follow C semantics where those are defined.

```
fn main() {
    let value: i64 = 1000;
    println!("as u16: {}", value as u16);
    println!("as i16: {}", value as i16);
    println!("as u8: {}", value as u8);
}
```

The results of `as` are *always* defined in Rust and consistent across platforms. This might not match your intuition for changing sign or casting to a smaller type – check the docs, and comment for clarity.

Casting with `as` is a relatively sharp tool that is easy to use incorrectly, and can be a source of subtle bugs as future maintenance work changes the types that are used or the ranges of values in types. Casts are best used only when the intent is to indicate unconditional truncation (e.g. selecting the bottom 32 bits of a `u64` with `as u32`, regardless of what was in the high bits).

For infallible casts (e.g. `u32` to `u64`), prefer using `From` or `Into` over `as` to confirm that the cast is in fact infallible. For fallible casts, `TryFrom` and `TryInto` are available when you want to handle casts that fit differently from those that don't.

Consider taking a break after this slide.

`as` is similar to a C++ static cast. Use of `as` in cases where data might be lost is generally discouraged, or at least deserves an explanatory comment.

This is common in casting integers to `usize` for use as an index.

17.5 Read ve Write

Using `Read` and `BufRead`, you can abstract over `u8` sources:

```
use std::io::{BufRead, BufReader, Read, Result};

fn count_lines<R: Read>(reader: R) -> usize {
    let buf_reader = BufReader::new(reader);
    buf_reader.lines().count()
}

fn main() -> Result<()> {
    let slice: &[u8] = b"foo\nbar\nbaz\n";
    println!("lines in slice: {}", count_lines(slice));
}
```

```

    let file = std::fs::File::open(std::env::current_exe())?;
    println!("lines in file: {}", count_lines(file));
    Ok(())
}

```

Similarly, `Write` lets you abstract over u8 sinks:

```

use std::io::{Result, Write};

fn log<W: Write>(writer: &mut W, msg: &str) -> Result<()> {
    writer.write_all(msg.as_bytes())?;
    writer.write_all("\n".as_bytes())
}

fn main() -> Result<()> {
    let mut buffer = Vec::new();
    log(&mut buffer, "Merhaba")?;
    log(&mut buffer, "Dünya")?;
    println!("Logged: {buffer:?}");
    Ok(())
}

```

17.6 The Default Trait

`Default` trait produces a default value for a type.

```

struct Derived {
    x: u32,
    y: String,
    z: Implemented,
}

struct Implemented(String);

impl Default for Implemented {
    fn default() -> Self {
        Self("John Smith".into())
    }
}

fn main() {
    let default_struct = Derived::default();
    println!("{default_struct:#?}");

    let almost_default_struct =
        Derived { y: "Y is set!".into(), ..Derived::default() };
    println!("{almost_default_struct:#?}");

    let nothing: Option<Derived> = None;
    println!("{:#?}", nothing.unwrap_or_default());
}

```

```
}
```

- It can be implemented directly or it can be derived via `#[derive(Default)]`.
- A derived implementation will produce a value where all fields are set to their default values.
 - This means all types in the struct must implement `Default` too.
- Standard Rust types often implement `Default` with reasonable values (e.g. `0`, `"`, etc).
- The partial struct initialization works nicely with default.
- The Rust standard library is aware that types can implement `Default` and provides convenience methods that use it.
- The `..` syntax is called **struct update syntax**.

17.7 Çevreleyiciler (Closures)

Closures or lambda expressions have types which cannot be named. However, they implement special `Fn`, `FnMut`, and `FnOnce` traits:

```
fn apply_and_log(func: impl FnOnce(i32) -> i32, func_name: &str, input: i32) {
    println!("Calling {func_name}({input}): {}", func(input))
}

fn main() {
    let n = 3;
    let add_3 = |x| x + n;
    apply_and_log(&add_3, "add_3", 10);
    apply_and_log(&add_3, "add_3", 20);

    let mut v = Vec::new();
    let mut accumulate = |x: i32| {
        v.push(x);
        v.iter().sum::<i32>()
    };
    apply_and_log(&mut accumulate, "accumulate", 4);
    apply_and_log(&mut accumulate, "accumulate", 5);

    let multiply_sum = |x| x * v.into_iter().sum::<i32>();
    apply_and_log(multiply_sum, "multiply_sum", 3);
}
```

An `Fn` (e.g. `add_3`) neither consumes nor mutates captured values. It can be called needing only a shared reference to the closure, which means the closure can be executed repeatedly and even concurrently.

An `FnMut` (e.g. `accumulate`) might mutate captured values. The closure object is accessed via exclusive reference, so it can be called repeatedly but not concurrently.

If you have an `FnOnce` (e.g. `multiply_sum`), you may only call it once. Doing so consumes the closure and any values captured by move.

`FnMut` is a subtype of `FnOnce`. `Fn` is a subtype of `FnMut` and `FnOnce`. I.e. you can use an `FnMut` wherever an `FnOnce` is called for, and you can use an `Fn` wherever an `FnMut` or `FnOnce` is called for.

When you define a function that takes a closure, you should take `FnOnce` if you can (i.e. you call it once), or `FnMut` else, and last `Fn`. This allows the most flexibility for the caller.

In contrast, when you have a closure, the most flexible you can have is `Fn` (which can be passed to a consumer of any of the 3 closure traits), then `FnMut`, and lastly `FnOnce`.

The compiler also infers `Copy` (e.g. for `add_3`) and `Clone` (e.g. `multiply_sum`), depending on what the closure captures. Function pointers (references to `fn` items) implement `Copy` and `Fn`.

By default, closures will capture each variable from an outer scope by the least demanding form of access they can (by shared reference if possible, then exclusive reference, then by move). The `move` keyword forces capture by value.

```
fn make_greeter(prefix: String) -> impl Fn(&str) {
    return move |name| println!("{}", prefix, name);
}

fn main() {
    let hi = make_greeter("Hi".to_string());
    hi("Greg");
}
```

17.8 Alıştırma: ROT13

In this example, you will implement the classic **“ROT13” cipher**. Copy this code to the playground, and implement the missing bits. Only rotate ASCII alphabetic characters, to ensure the result is still valid UTF-8.

```
use std::io::Read;

struct RotDecoder<R: Read> {
    input: R,
    rot: u8,
}

// Implement the `Read` trait for `RotDecoder`.

fn main() {
    let mut rot =
        RotDecoder { input: "Gb trg gb gur bgure fvqr!".as_bytes(), rot: 13 };
    let mut result = String::new();
    rot.read_to_string(&mut result).unwrap();
    println!("{}", result);
}

mod test {
    use super::*;

    fn joke() {
        let mut rot =
            RotDecoder { input: "Gb trg gb gur bgure fvqr!".as_bytes(), rot: 13 };
    }
}
```

```

    let mut result = String::new();
    rot.read_to_string(&mut result).unwrap();
    assert_eq!(&result, "To get to the other side!");
}

fn binary() {
    let input: Vec<u8> = (0..=255u8).collect();
    let mut rot = RotDecoder::<&[u8]> { input: input.as_ref(), rot: 13 };
    let mut buf = [0u8; 256];
    assert_eq!(rot.read(&mut buf).unwrap(), 256);
    for i in 0..=255 {
        if input[i] != buf[i] {
            assert!(input[i].is_ascii_alphabetic());
            assert!(buf[i].is_ascii_alphabetic());
        }
    }
}
}
}

```

What happens if you chain two RotDecoder instances together, each rotating by 13 characters?

17.8.1 Çözüm

```

use std::io::Read;

struct RotDecoder<R: Read> {
    input: R,
    rot: u8,
}

impl<R: Read> Read for RotDecoder<R> {
    fn read(&mut self, buf: &mut [u8]) -> std::io::Result<usize> {
        let size = self.input.read(buf)?;
        for b in &mut buf[..size] {
            if b.is_ascii_alphabetic() {
                let base = if b.is_ascii_uppercase() { 'A' } else { 'a' } as u8;
                *b = (*b - base + self.rot) % 26 + base;
            }
        }
        Ok(size)
    }
}

fn main() {
    let mut rot =
        RotDecoder { input: "Gb trg gb gur bgure fvqr!".as_bytes(), rot: 13 };
    let mut result = String::new();
    rot.read_to_string(&mut result).unwrap();
    println!("{}", result);
}

```

```

mod test {
  use super::*;

  fn joke() {
    let mut rot =
      RotDecoder { input: "Gb trg gb gur bgure fvqr!".as_bytes(), rot: 13 };
    let mut result = String::new();
    rot.read_to_string(&mut result).unwrap();
    assert_eq!(&result, "To get to the other side!");
  }

  fn binary() {
    let input: Vec<u8> = (0..=255u8).collect();
    let mut rot = RotDecoder::<&[u8]> { input: input.as_ref(), rot: 13 };
    let mut buf = [0u8; 256];
    assert_eq!(rot.read(&mut buf).unwrap(), 256);
    for i in 0..=255 {
      if input[i] != buf[i] {
        assert!(input[i].is_ascii_alphabetic());
        assert!(buf[i].is_ascii_alphabetic());
      }
    }
  }
}

```

Kısım V

Gün 3: Sabah

Bölüm 18

Welcome to Day 3

Today, we will cover:

- Memory management, lifetimes, and the borrow checker: how Rust ensures memory safety.
- Smart pointers: standard library pointer types.

Zamanlama (Schedule)

Bu oturum 10 dakikalık aralar dahil yaklaşık 2 saat 20 dakika sürmelidir. İçeriği:

Bölüm	Süre
Hoş Geldiniz	3 dakika
Bellek Yönetimi	1 saat
Akıllı Göstericiler	55 dakika

Bölüm 19

Bellek Yönetimi

Bu bölüm yaklaşık 1 saat sürmelidir. İçeriği:

Slayt	Süre
Program Belleğinin Gözden Geçirilmesi	5 dakika
Bellek Yönetimine Yaklaşımlar	10 dakika
Sahiplik	5 dakika
Taşıma Semantiği	5 dakika
Clone	2 dakika
Kopyalanan Türler	5 dakika
Drop	10 dakika
Alıştırma: İnşa Edici / Yapıcı Tür (Builder Type)	20 dakika

19.1 Program Belleğinin Gözden Geçirilmesi

Programs allocate memory in two ways:

- Stack: Continuous area of memory for local variables.
 - Values have fixed sizes known at compile time.
 - Extremely fast: just move a stack pointer.
 - Easy to manage: follows function calls.
 - Great memory locality.
- Heap: Storage of values outside of function calls.
 - Values have dynamic sizes determined at runtime.
 - Slightly slower than the stack: some book-keeping needed.
 - No guarantee of memory locality.

Örnek

Creating a String puts fixed-sized metadata on the stack and dynamically sized data, the actual string, on the heap:

```
fn main() {
    let s1 = String::from("Merhaba");
}
```

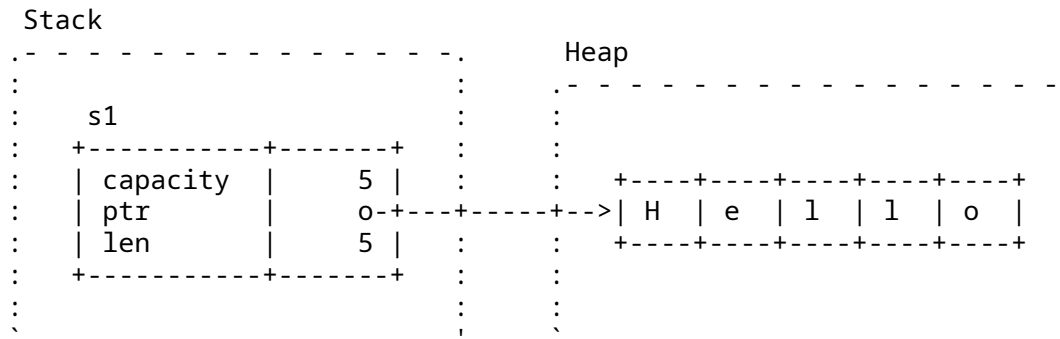

- Mention that a String is backed by a Vec, so it has a capacity and length and can grow if mutable via reallocation on the heap.
- If students ask about it, you can mention that the underlying memory is heap allocated using the **System Allocator** and custom allocators can be implemented using the **Allocator API**

Daha Fazlasını Keşfedin

We can inspect the memory layout with unsafe Rust. However, you should point out that this is rightfully unsafe!

```
fn main() {
    let mut s1 = String::from("Merhaba");
    s1.push(' ');
    s1.push_str("dünya");
    // DON'T DO THIS AT HOME! For educational purposes only.
    // String provides no guarantees about its layout, so this could lead to
    // undefined behavior.
    unsafe {
        let (capacity, ptr, len): (usize, usize, usize) = std::mem::transmute(s1);
        println!("capacity = {capacity}, ptr = {ptr:#x}, len = {len}");
    }
}
```

19.2 Bellek Yönetimine Yaklaşımlar

Traditionally, languages have fallen into two broad categories:

- Full control via manual memory management: C, C++, Pascal, ...
 - Programmer decides when to allocate or free heap memory.
 - Programmer must determine whether a pointer still points to valid memory.
 - Studies show, programmers make mistakes.
- Full safety via automatic memory management at runtime: Java, Python, Go, Haskell, ...
 - A runtime system ensures that memory is not freed until it can no longer be referenced.

- Genellikle referans sayımı veya çöp toplama ile uygulanır.

Rust offers a new mix:

Full control *and* safety via compile time enforcement of correct memory management.

It does this with an explicit ownership concept.

This slide is intended to help students coming from other languages to put Rust in context.

- C must manage heap manually with `malloc` and `free`. Common errors include forgetting to call `free`, calling it multiple times for the same pointer, or dereferencing a pointer after the memory it points to has been freed.
- C++ has tools like smart pointers (`unique_ptr`, `shared_ptr`) that take advantage of language guarantees about calling destructors to ensure memory is freed when a function returns. It is still quite easy to mis-use these tools and create similar bugs to C.
- Java, Go, and Python rely on the garbage collector to identify memory that is no longer reachable and discard it. This guarantees that any pointer can be dereferenced, eliminating use-after-free and other classes of bugs. But, GC has a runtime cost and is difficult to tune properly.

Rust's ownership and borrowing model can, in many cases, get the performance of C, with `alloc` and `free` operations precisely where they are required -- zero cost. It also provides tools similar to C++'s smart pointers. When required, other options such as reference counting are available, and there are even third-party crates available to support runtime garbage collection (not covered in this class).

19.3 Sahiplik

All variable bindings have a *scope* where they are valid and it is an error to use a variable outside its scope:

```
struct Point(i32, i32);

fn main() {
    {
        let p = Point(3, 4);
        println!("x: {}", p.0);
    }
    println!("y: {}", p.1);
}
```

We say that the variable *owns* the value. Every Rust value has precisely one owner at all times.

At the end of the scope, the variable is *dropped* and the data is freed. A destructor can run here to free up resources.

Students familiar with garbage-collection implementations will know that a garbage collector starts with a set of "roots" to find all reachable memory. Rust's "single owner" principle is a similar idea.

19.4 Taşıma Semantiği

An assignment will transfer *ownership* between variables:

```
fn main() {  
    let s1: String = String::from("Merhaba!");  
    let s2: String = s1;  
    println!("s2: {s2}");  
    // println!("s1: {s1}");  
}
```

- The assignment of `s1` to `s2` transfers ownership.
- When `s1` goes out of scope, nothing happens: it does not own anything.
- When `s2` goes out of scope, the string data is freed.

Before move to `s2`:

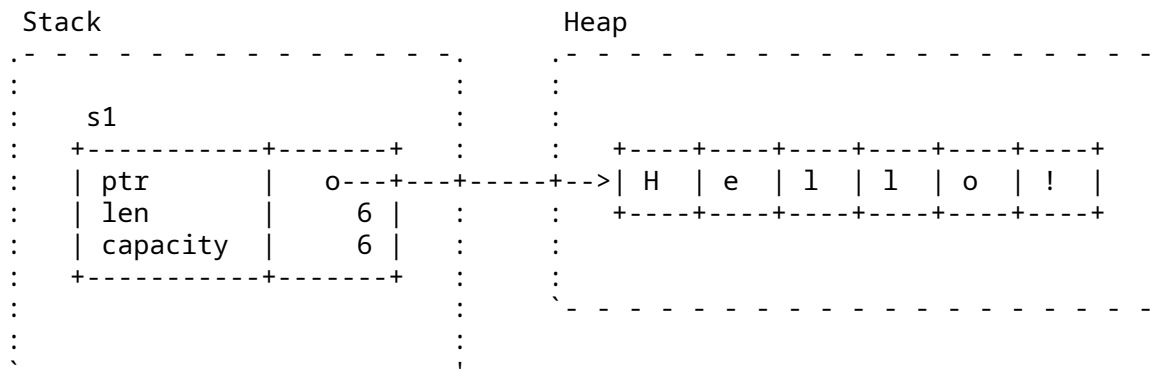

After move to `s2`:

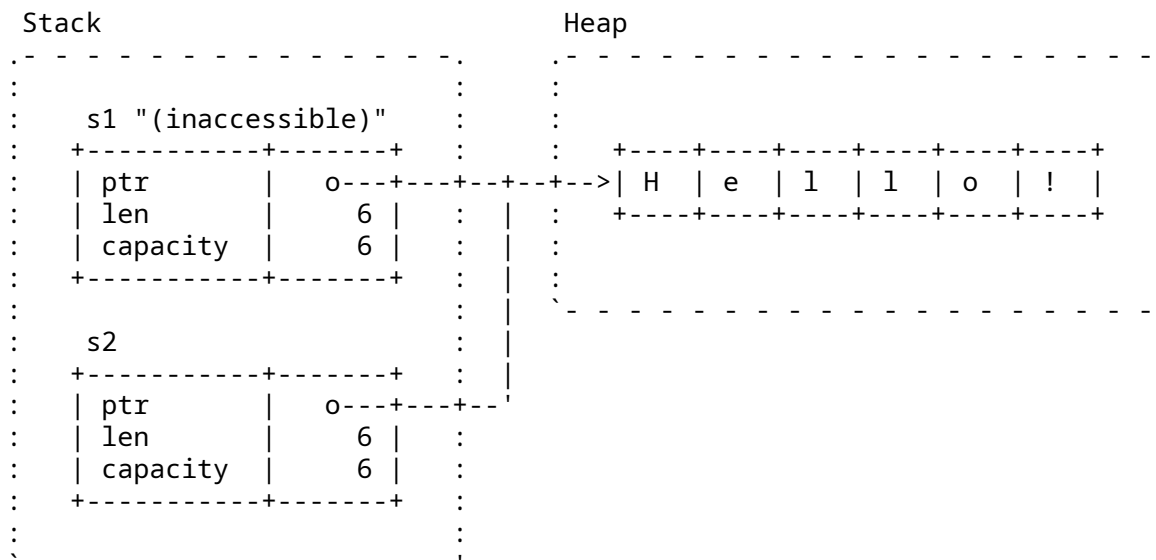

When you pass a value to a function, the value is assigned to the function parameter. This transfers ownership:

```
fn say_hello(name: String) {
```

```

println!("Merhaba {name}")
}

fn main() {
    let name = String::from("Alice");
    say_hello(name);
    // say_hello(name);
}

```

- Mention that this is the opposite of the defaults in C++, which copies by value unless you use `std::move` (and the move constructor is defined!).
- It is only the ownership that moves. Whether any machine code is generated to manipulate the data itself is a matter of optimization, and such copies are aggressively optimized away.
- Simple values (such as integers) can be marked Copy (see later slides).
- In Rust, clones are explicit (by using `clone`).

In the `say_hello` example:

- With the first call to `say_hello`, `main` gives up ownership of `name`. Afterwards, `name` cannot be used anymore within `main`.
- The heap memory allocated for `name` will be freed at the end of the `say_hello` function.
- `main` can retain ownership if it passes `name` as a reference (`&name`) and if `say_hello` accepts a reference as a parameter.
- Alternatively, `main` can pass a clone of `name` in the first call (`name.clone()`).
- Rust makes it harder than C++ to inadvertently create copies by making move semantics the default, and by forcing programmers to make clones explicit.

Daha Fazlasını Keşfedin

Defensive Copies in Modern C++

Modern C++ solves this differently:

```

std::string s1 = "Cpp";
std::string s2 = s1; // Duplicate the data in s1.

```

- The heap data from `s1` is duplicated and `s2` gets its own independent copy.
- When `s1` and `s2` go out of scope, they each free their own memory.

Before copy-assignment:

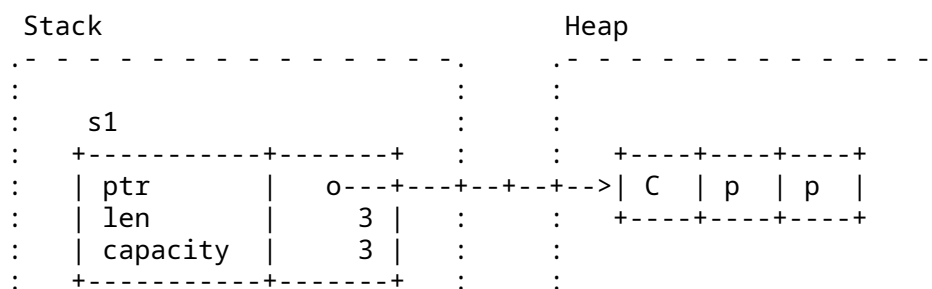

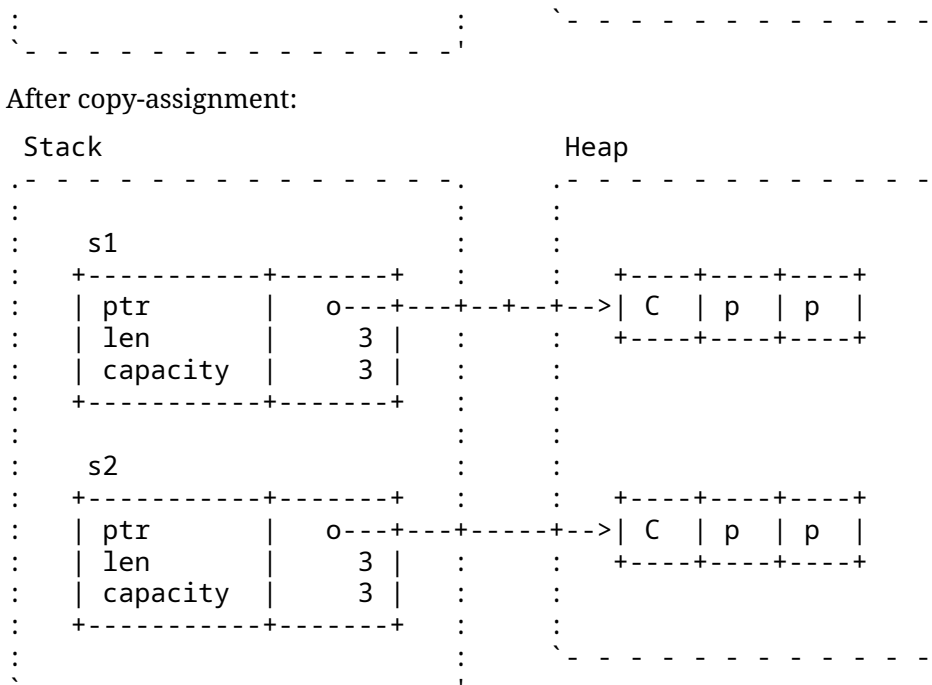

Anahtar noktalar:

- C++ has made a slightly different choice than Rust. Because `=` copies data, the string data has to be cloned. Otherwise we would get a double-free when either string goes out of scope.
- C++ also has `std::move`, which is used to indicate when a value may be moved from. If the example had been `s2 = std::move(s1)`, no heap allocation would take place. After the move, `s1` would be in a valid but unspecified state. Unlike Rust, the programmer is allowed to keep using `s1`.
- Unlike Rust, `=` in C++ can run arbitrary code as determined by the type which is being copied or moved.

19.5 Clone

Sometimes you *want* to make a copy of a value. The `Clone` trait accomplishes this.

```

fn say_hello(name: String) {
    println!("Merhaba {name}")
}

fn main() {
    let name = String::from("Alice");
    say_hello(name.clone());
    say_hello(name);
}

```

- The idea of `Clone` is to make it easy to spot where heap allocations are occurring. Look for `.clone()` and a few others like `vec!` or `Box::new`.

- It's common to "clone your way out" of problems with the borrow checker, and return later to try to optimize those clones away.
- `clone` generally performs a deep copy of the value, meaning that if you e.g. clone an array, all of the elements of the array are cloned as well.
- The behavior for `clone` is user-defined, so it can perform custom cloning logic if needed.

19.6 Kopyalanan Türler

While move semantics are the default, certain types are copied by default:

```
fn main() {
    let x = 42;
    let y = x;
    println!("x: {x}"); // would not be accessible if not Copy
    println!("y: {y}");
}
```

These types implement the `Copy` trait.

You can opt-in your own types to use copy semantics:

```
struct Point(i32, i32);

fn main() {
    let p1 = Point(3, 4);
    let p2 = p1;
    println!("p1: {p1:?}");
    println!("p2: {p2:?}");
}
```

- After the assignment, both `p1` and `p2` own their own data.
- We can also use `p1.clone()` to explicitly copy the data.

Copying and cloning are not the same thing:

- Copying refers to bitwise copies of memory regions and does not work on arbitrary objects.
- Copying does not allow for custom logic (unlike copy constructors in C++).
- Cloning is a more general operation and also allows for custom behavior by implementing the `Clone` trait.
- Copying does not work on types that implement the `Drop` trait.

In the above example, try the following:

- Add a `String` field to `struct Point`. It will not compile because `String` is not a `Copy` type.
- Remove `Copy` from the derive attribute. The compiler error is now in the `println!` for `p1`.
- Show that it works if you clone `p1` instead.

Daha Fazlasını Keşfedin

- Shared references are Copy/Clone, mutable references are not. This is because Rust requires that mutable references be exclusive, so while it's valid to make a copy of a shared reference, creating a copy of a mutable reference would violate Rust's borrowing rules.

19.7 The Drop Trait

Values which implement `Drop` can specify code to run when they go out of scope:

```
struct Droppable {
    name: &'static str,
}

impl Drop for Droppable {
    fn drop(&mut self) {
        println!("Dropping {}", self.name);
    }
}

fn main() {
    let a = Droppable { name: "a" };
    {
        let b = Droppable { name: "b" };
        {
            let c = Droppable { name: "c" };
            let d = Droppable { name: "d" };
            println!("Exiting block B");
        }
        println!("Exiting block A");
    }
    drop(a);
    println!("Exiting main");
}
```

- Note that `std::mem::drop` is not the same as `std::ops::Drop::drop`.
- Values are automatically dropped when they go out of scope.
- When a value is dropped, if it implements `std::ops::Drop` then its `Drop::drop` implementation will be called.
- All its fields will then be dropped too, whether or not it implements `Drop`.
- `std::mem::drop` is just an empty function that takes any value. The significance is that it takes ownership of the value, so at the end of its scope it gets dropped. This makes it a convenient way to explicitly drop values earlier than they would otherwise go out of scope.
 - This can be useful for objects that do some work on drop: releasing locks, closing files, etc.

Discussion points:

- Why doesn't `Drop::drop` take `self`?

- Short-answer: If it did, `std::mem::drop` would be called at the end of the block, resulting in another call to `Drop::drop`, and a stack overflow!
- Try replacing `drop(a)` with `a.drop()`.

19.8 Alıştırma: İnşa Edici / Yapıcı Tür (Builder Type)

In this example, we will implement a complex data type that owns all of its data. We will use the "builder pattern" to support building a new value piece-by-piece, using convenience functions.

Fill in the missing pieces.

```
enum Language {
    Rust,
    Java,
    Perl,
}

struct Dependency {
    name: String,
    version_expression: String,
}

/// A representation of a software package.
struct Package {
    name: String,
    version: String,
    authors: Vec<String>,
    dependencies: Vec<Dependency>,
    language: Option<Language>,
}

impl Package {
    /// Return a representation of this package as a dependency, for use in
    /// building other packages.
    fn as_dependency(&self) -> Dependency {
        todo!("1")
    }
}

/// A builder for a Package. Use `build()` to create the `Package` itself.
struct PackageBuilder(Package);

impl PackageBuilder {
    fn new(name: impl Into<String>) -> Self {
        todo!("2")
    }

    /// Set the package version.
    fn version(mut self, version: impl Into<String>) -> Self {
        self.0.version = version.into();
    }
}
```

```

    self
}

/// Set the package authors.
fn authors(mut self, authors: Vec<String>) -> Self {
    todo!("3")
}

/// Add an additional dependency.
fn dependency(mut self, dependency: Dependency) -> Self {
    todo!("4")
}

/// Set the language. If not set, language defaults to None.
fn language(mut self, language: Language) -> Self {
    todo!("5")
}

fn build(self) -> Package {
    self.0
}
}

fn main() {
    let base64 = PackageBuilder::new("base64").version("0.13").build();
    println!("base64: {base64:?}");
    let log =
        PackageBuilder::new("log").version("0.4").language(Language::Rust).build();
    println!("log: {log:?}");
    let serde = PackageBuilder::new("serde")
        .authors(vec!["djmitche".into()])
        .version(String::from("4.0"))
        .dependency(base64.as_dependency())
        .dependency(log.as_dependency())
        .build();
    println!("serde: {serde:?}");
}

```

19.8.1 Çözüm

```

enum Language {
    Rust,
    Java,
    Perl,
}

struct Dependency {
    name: String,
    version_expression: String,
}

```

```

/// A representation of a software package.
struct Package {
    name: String,
    version: String,
    authors: Vec<String>,
    dependencies: Vec<Dependency>,
    language: Option<Language>,
}

impl Package {
    /// Return a representation of this package as a dependency, for use in
    /// building other packages.
    fn as_dependency(&self) -> Dependency {
        Dependency {
            name: self.name.clone(),
            version_expression: self.version.clone(),
        }
    }
}

/// A builder for a Package. Use `build()` to create the `Package` itself.
struct PackageBuilder(Package);

impl PackageBuilder {
    fn new(name: impl Into<String>) -> Self {
        Self(Package {
            name: name.into(),
            version: "0.1".into(),
            authors: vec![],
            dependencies: vec![],
            language: None,
        })
    }

    /// Set the package version.
    fn version(mut self, version: impl Into<String>) -> Self {
        self.0.version = version.into();
        self
    }

    /// Set the package authors.
    fn authors(mut self, authors: Vec<String>) -> Self {
        self.0.authors = authors;
        self
    }

    /// Add an additional dependency.
    fn dependency(mut self, dependency: Dependency) -> Self {
        self.0.dependencies.push(dependency);
        self
    }
}

```

```

/// Set the language. If not set, language defaults to None.
fn language(mut self, language: Language) -> Self {
    self.0.language = Some(language);
    self
}

fn build(self) -> Package {
    self.0
}

}

fn main() {
    let base64 = PackageBuilder::new("base64").version("0.13").build();
    println!("base64: {base64:?}");
    let log =
        PackageBuilder::new("log").version("0.4").language(Language::Rust).build();
    println!("log: {log:?}");
    let serde = PackageBuilder::new("serde")
        .authors(vec!["djmitche".into()])
        .version(String::from("4.0"))
        .dependency(base64.as_dependency())
        .dependency(log.as_dependency())
        .build();
    println!("serde: {serde:?}");
}

```

Bölüm 20

Akıllı Göstericiler

Bu bölüm yaklaşık 55 dakika sürmelidir. İçerir:

Slayt	Süre
Box	

| 10 dakika | | Rc | 5 dakika | | Sahipli Özellik Nesneleri (Owned Trait Objects) | 10 dakika |
| Alıştırma: İkili Ağaç | 30 dakika |

20.1 Box<T>

Box is an owned pointer to data on the heap:

```
fn main() {  
    let five = Box::new(5);  
    println!("five: {}", *five);  
}
```

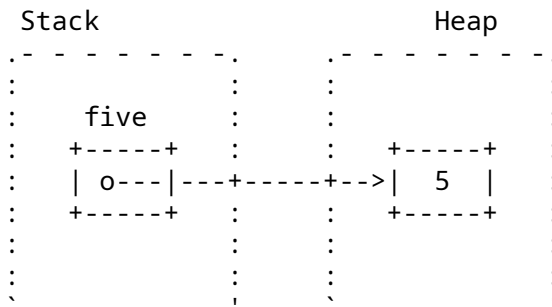

`Box<T>` implements `Deref<Target = T>`, which means that you can **call methods from T directly on a `Box<T>`**.

Recursive data types or data types with dynamic sizes cannot be stored inline without a pointer indirection. `Box` accomplishes that indirection:

```

enum List<T> {
    // A non-empty list: first element and the rest of the list.
    Element(T, Box<List<T>>),
    // An empty list.
    Nil,
}

fn main() {
    let list: List<i32> =
        List::Element(1, Box::new(List::Element(2, Box::new(List::Nil))));
    println!("{}", list);
}

```

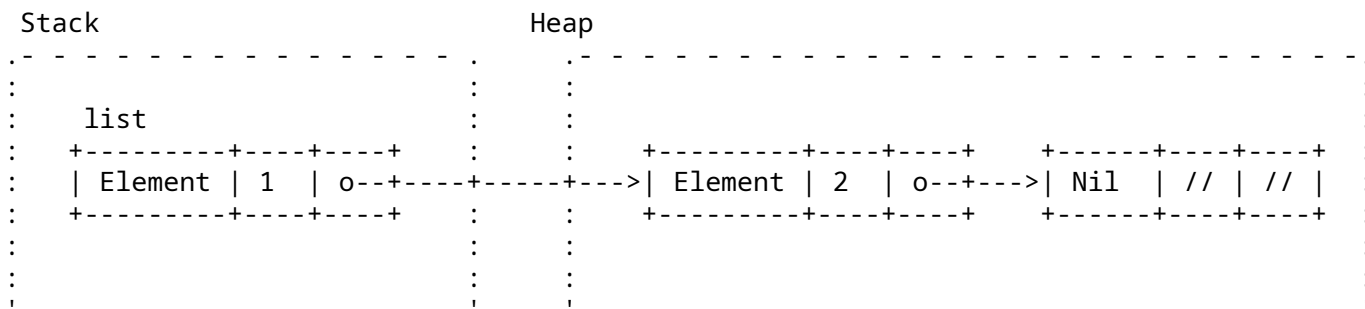

- Box is like `std::unique_ptr` in C++, except that it's guaranteed to be not null.
- A Box can be useful when you:
 - have a type whose size can't be known at compile time, but the Rust compiler wants to know an exact size.
 - want to transfer ownership of a large amount of data. To avoid copying large amounts of data on the stack, instead store the data on the heap in a Box so only the pointer is moved.
- If Box was not used and we attempted to embed a List directly into the List, the compiler would not be able to compute a fixed size for the struct in memory (the List would be of infinite size).
- Box solves this problem as it has the same size as a regular pointer and just points at the next element of the List in the heap.
- Remove the Box in the List definition and show the compiler error. We get the message "recursive without indirection", because for data recursion, we have to use indirection, a Box or reference of some kind, instead of storing the value directly.
- Though Box looks like `std::unique_ptr` in C++, it cannot be empty/null. This makes Box one of the types that allow the compiler to optimize storage of some enums (the "niche optimization").

20.2 Rc

Rc is a reference-counted shared pointer. Use this when you need to refer to the same data from multiple places:

```

use std::rc::Rc;

fn main() {
    let a = Rc::new(10);
    let b = Rc::clone(&a);

    println!("a: {a}");
    println!("b: {b}");
}

```

- See [Arc](#) and [Mutex](#) if you are in a multi-threaded context.
- You can *downgrade* a shared pointer into a [Weak](#) pointer to create cycles that will get dropped.
- Rc's count ensures that its contained value is valid for as long as there are references.
- Rc in Rust is like `std::shared_ptr` in C++.
- `Rc::clone` is cheap: it creates a pointer to the same allocation and increases the reference count. Does not make a deep clone and can generally be ignored when looking for performance issues in code.
- `make_mut` actually clones the inner value if necessary ("clone-on-write") and returns a mutable reference.
- Use `Rc::strong_count` to check the reference count.
- `Rc::downgrade` gives you a *weakly reference-counted* object to create cycles that will be dropped properly (likely in combination with `RefCell`).

20.3 Sahipli Özellik Nesneleri (Owned Trait Objects)

We previously saw how trait objects can be used with references, e.g `&dyn Pet`. However, we can also use trait objects with smart pointers like `Box` to create an owned trait object: `Box<dyn Pet>`.

```

struct Dog {
    name: String,
    age: i8,
}

struct Cat {
    lives: i8,
}

trait Pet {
    fn talk(&self) -> String;
}

impl Pet for Dog {
    fn talk(&self) -> String {
        format!("Woof, my name is {}!", self.name)
    }
}

impl Pet for Cat {
    fn talk(&self) -> String {

```

```

        String::from("Miau!")
    }
}

fn main() {
    let pets: Vec<Box<dyn Pet>> = vec![
        Box::new(Cat { lives: 9 }),
        Box::new(Dog { name: String::from("Fido"), age: 5 }),
    ];
    for pet in pets {
        println!("Merhaba, nasılsın? {}", pet.talk());
    }
}

```

Memory layout after allocating pets:

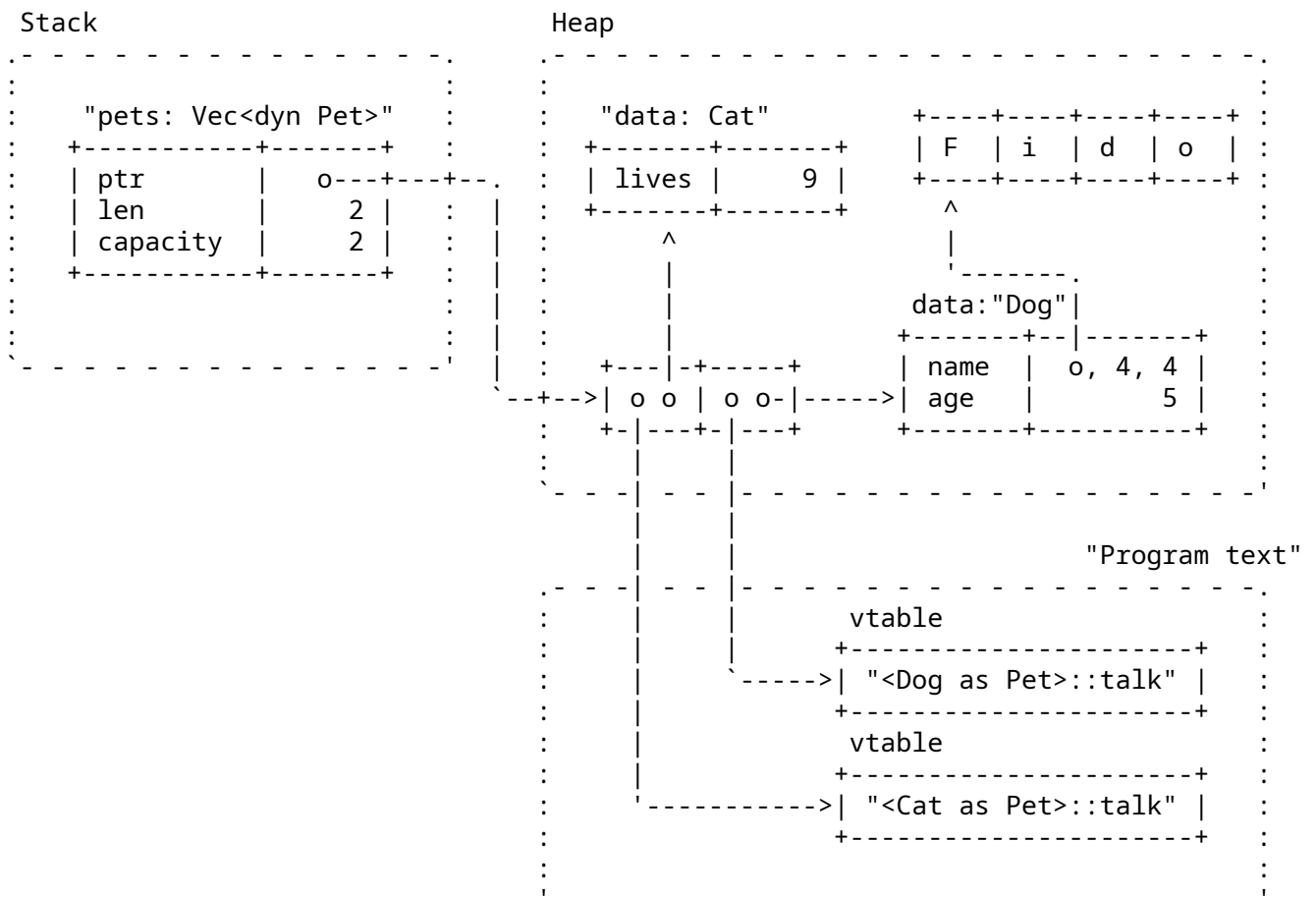

- Types that implement a given trait may be of different sizes. This makes it impossible to have things like `Vec<dyn Pet>` in the example above.
- `dyn Pet` is a way to tell the compiler about a dynamically sized type that implements `Pet`.
- In the example, `pets` is allocated on the stack and the vector data is on the heap. The two vector elements are *fat pointers*:

- A fat pointer is a double-width pointer. It has two components: a pointer to the actual object and a pointer to the **virtual method table** (vtable) for the Pet implementation of that particular object.
- The data for the Dog named Fido is the name and age fields. The Cat has a lives field.
- Compare these outputs in the above example:

```
println!("{}", std::mem::size_of::<Dog>(), std::mem::size_of::<Cat>());
println!("{}", std::mem::size_of::<&Dog>(), std::mem::size_of::<&Cat>());
println!("{}", std::mem::size_of::<&dyn Pet>());
println!("{}", std::mem::size_of::<Box<dyn Pet>>());
```

20.4 Alıştırma: İkili Ağaç

A binary tree is a tree-type data structure where every node has two children (left and right). We will create a tree where each node stores a value. For a given node N, all nodes in a N's left subtree contain smaller values, and all nodes in N's right subtree will contain larger values.

Implement the following types, so that the given tests pass.

Extra Credit: implement an iterator over a binary tree that returns the values in order.

```
/// A node in the binary tree.
struct Node<T: Ord> {
    value: T,
    left: Subtree<T>,
    right: Subtree<T>,
}

/// A possibly-empty subtree.
struct Subtree<T: Ord>(Option<Box<Node<T>>>);

/// A container storing a set of values, using a binary tree.
///
/// If the same value is added multiple times, it is only stored once.
pub struct BinaryTree<T: Ord> {
    root: Subtree<T>,
}

impl<T: Ord> BinaryTree<T> {
    fn new() -> Self {
        Self { root: Subtree::new() }
    }

    fn insert(&mut self, value: T) {
        self.root.insert(value);
    }

    fn has(&self, value: &T) -> bool {
        self.root.has(value)
    }
}
```

```

    fn len(&self) -> usize {
        self.root.len()
    }
}

// Implement `new`, `insert`, `len`, and `has` for `Subtree`.

mod tests {
    use super::*;

    fn len() {
        let mut tree = BinaryTree::new();
        assert_eq!(tree.len(), 0);
        tree.insert(2);
        assert_eq!(tree.len(), 1);
        tree.insert(1);
        assert_eq!(tree.len(), 2);
        tree.insert(2); // not a unique item
        assert_eq!(tree.len(), 2);
    }

    fn has() {
        let mut tree = BinaryTree::new();
        fn check_has(tree: &BinaryTree<i32>, exp: &[bool]) {
            let got: Vec<bool> =
                (0..exp.len()).map(|i| tree.has(&(i as i32))).collect();
            assert_eq!(&got, exp);
        }

        check_has(&tree, &[false, false, false, false, false]);
        tree.insert(0);
        check_has(&tree, &[true, false, false, false, false]);
        tree.insert(4);
        check_has(&tree, &[true, false, false, false, true]);
        tree.insert(4);
        check_has(&tree, &[true, false, false, false, true]);
        tree.insert(3);
        check_has(&tree, &[true, false, false, true, true]);
    }

    fn unbalanced() {
        let mut tree = BinaryTree::new();
        for i in 0..100 {
            tree.insert(i);
        }
        assert_eq!(tree.len(), 100);
        assert!(tree.has(&50));
    }
}

```

20.4.1 Çözüm

```
use std::cmp::Ordering;

/// A node in the binary tree.
struct Node<T: Ord> {
    value: T,
    left: Subtree<T>,
    right: Subtree<T>,
}

/// A possibly-empty subtree.
struct Subtree<T: Ord>(Option<Box<Node<T>>>);

/// A container storing a set of values, using a binary tree.
///
/// If the same value is added multiple times, it is only stored once.
pub struct BinaryTree<T: Ord> {
    root: Subtree<T>,
}

impl<T: Ord> BinaryTree<T> {
    fn new() -> Self {
        Self { root: Subtree::new() }
    }

    fn insert(&mut self, value: T) {
        self.root.insert(value);
    }

    fn has(&self, value: &T) -> bool {
        self.root.has(value)
    }

    fn len(&self) -> usize {
        self.root.len()
    }
}

impl<T: Ord> Subtree<T> {
    fn new() -> Self {
        Self(None)
    }

    fn insert(&mut self, value: T) {
        match &mut self.0 {
            None => self.0 = Some(Box::new(Node::new(value))),
            Some(n) => match value.cmp(&n.value) {
                Ordering::Less => n.left.insert(value),
                Ordering::Equal => {},
                Ordering::Greater => n.right.insert(value),
            }
        }
    }
}
```

```

    },
  }
}

fn has(&self, value: &T) -> bool {
  match &self.0 {
    None => false,
    Some(n) => match value.cmp(&n.value) {
      Ordering::Less => n.left.has(value),
      Ordering::Equal => true,
      Ordering::Greater => n.right.has(value),
    },
  }
}

fn len(&self) -> usize {
  match &self.0 {
    None => 0,
    Some(n) => 1 + n.left.len() + n.right.len(),
  }
}
}

impl<T: Ord> Node<T> {
  fn new(value: T) -> Self {
    Self { value, left: Subtree::new(), right: Subtree::new() }
  }
}

fn main() {
  let mut tree = BinaryTree::new();
  tree.insert("foo");
  assert_eq!(tree.len(), 1);
  tree.insert("bar");
  assert!(tree.has(&"foo"));
}

mod tests {
  use super::*;

  fn len() {
    let mut tree = BinaryTree::new();
    assert_eq!(tree.len(), 0);
    tree.insert(2);
    assert_eq!(tree.len(), 1);
    tree.insert(1);
    assert_eq!(tree.len(), 2);
    tree.insert(2); // not a unique item
    assert_eq!(tree.len(), 2);
  }
}

```

```

fn has() {
    let mut tree = BinaryTree::new();
    fn check_has(tree: &BinaryTree<i32>, exp: &[bool]) {
        let got: Vec<bool> =
            (0..exp.len()).map(|i| tree.has(&(i as i32))).collect();
        assert_eq!(&got, exp);
    }

    check_has(&tree, &[false, false, false, false, false]);
    tree.insert(0);
    check_has(&tree, &[true, false, false, false, false]);
    tree.insert(4);
    check_has(&tree, &[true, false, false, false, true]);
    tree.insert(4);
    check_has(&tree, &[true, false, false, false, true]);
    tree.insert(3);
    check_has(&tree, &[true, false, false, true, true]);
}

fn unbalanced() {
    let mut tree = BinaryTree::new();
    for i in 0..100 {
        tree.insert(i);
    }
    assert_eq!(tree.len(), 100);
    assert!(tree.has(&50));
}
}

```

Kısım VI

Gün 3: Öğleden Sonra

Bölüm 21

Tekrar Hoş Geldiniz

Bu oturum 10 dakikalık aralar dahil yaklaşık 1 saat 55 dakika sürmelidir. İçeriği:

Bölüm	Süre
Ödünç Alma	55 dakika
Ömürler (Lifetimes)	50 dakika

Bölüm 22

Ödünç Alma

Bu bölüm yaklaşık 55 dakika sürmelidir. İçerir:

Slayt	Süre
Bir Değeri Ödünç Alma	10 dakika
Ödünç Alma Kontrolü	10 dakika
Ödünç Alma Hataları	3 dakika
İç Değişebilirlik (Interior Mutability)	10 dakika
Alıştırma: Sağlık İstatistikleri	20 dakika

22.1 Bir Değeri Ödünç Alma

As we saw before, instead of transferring ownership when calling a function, you can let a function *borrow* the value:

```
struct Point(i32, i32);

fn add(p1: &Point, p2: &Point) -> Point {
    Point(p1.0 + p2.0, p1.1 + p2.1)
}

fn main() {
    let p1 = Point(3, 4);
    let p2 = Point(10, 20);
    let p3 = add(&p1, &p2);
    println!("{p1:?} + {p2:?} = {p3:?}");
}
```

- The `add` function *borrow*s two points and returns a new point.
- The caller retains ownership of the inputs.

This slide is a review of the material on references from day 1, expanding slightly to include function arguments and return values.

Daha Fazlasını Keşfedin

Notes on stack returns and inlining:

- Demonstrate that the return from `add` is cheap because the compiler can eliminate the copy operation, by inlining the call to `add` into `main`. Change the above code to print stack addresses and run it on the [Playground](#) or look at the assembly in [Godbolt](#). In the "DEBUG" optimization level, the addresses should change, while they stay the same when changing to the "RELEASE" setting:

```
struct Point(i32, i32);

fn add(p1: &Point, p2: &Point) -> Point {
    let p = Point(p1.0 + p2.0, p1.1 + p2.1);
    println!("&p.0: {:p}", &p.0);
    p
}

pub fn main() {
    let p1 = Point(3, 4);
    let p2 = Point(10, 20);
    let p3 = add(&p1, &p2);
    println!("&p3.0: {:p}", &p3.0);
    println!("{p1:?} + {p2:?} = {p3:?}");
}
```

- The Rust compiler can do automatic inlining, that can be disabled on a function level with `#[inline(never)]`.
- Once disabled, the printed address will change on all optimization levels. Looking at [Godbolt](#) or [Playground](#), one can see that in this case, the return of the value depends on the ABI, e.g. on amd64 the two `i32` that is making up the point will be returned in 2 registers (`eax` and `edx`).

22.2 Ödünç Alma Kontrolü

Rust's *borrow checker* puts constraints on the ways you can borrow values. For a given value, at any time:

- You can have one or more shared references to the value, *or*
- You can have exactly one exclusive reference to the value.

```
fn main() {
    let mut a: i32 = 10;
    let b: &i32 = &a;

    {
        let c: &mut i32 = &mut a;
        *c = 20;
    }

    println!("a: {a}");
}
```

```
println!("b: {b}");
}
```

- Note that the requirement is that conflicting references not *exist* at the same point. It does not matter where the reference is dereferenced.
- The above code does not compile because `a` is borrowed as mutable (through `c`) and as immutable (through `b`) at the same time.
- Move the `println!` statement for `b` before the scope that introduces `c` to make the code compile.
- After that change, the compiler realizes that `b` is only ever used before the new mutable borrow of `a` through `c`. This is a feature of the borrow checker called "non-lexical lifetimes".
- The exclusive reference constraint is quite strong. Rust uses it to ensure that data races do not occur. Rust also *relies* on this constraint to optimize code. For example, a value behind a shared reference can be safely cached in a register for the lifetime of that reference.
- The borrow checker is designed to accommodate many common patterns, such as taking exclusive references to different fields in a struct at the same time. But, there are some situations where it doesn't quite "get it" and this often results in "fighting with the borrow checker."

22.3 Ödünç Alma Hataları

As a concrete example of how these borrowing rules prevent memory errors, consider the case of modifying a collection while there are references to its elements:

```
fn main() {
    let mut vec = vec![1, 2, 3, 4, 5];
    let elem = &vec[2];
    vec.push(6);
    println!("{elem}");
}
```

Similarly, consider the case of iterator invalidation:

```
fn main() {
    let mut vec = vec![1, 2, 3, 4, 5];
    for elem in &vec {
        vec.push(elem * 2);
    }
}
```

- In both of these cases, modifying the collection by pushing new elements into it can potentially invalidate existing references to the collection's elements if the collection has to reallocate.

22.4 İç Değişebilirlik (Interior Mutability)

In some situations, it's necessary to modify data behind a shared (read-only) reference. For example, a shared data structure might have an internal cache, and wish to update that cache from read-only methods.

The "interior mutability" pattern allows exclusive (mutable) access behind a shared reference. The standard library provides several ways to do this, all while still ensuring safety, typically by performing a runtime check.

Cell

Cell wraps a value and allows getting or setting the value using only a shared reference to the Cell. However, it does not allow any references to the inner value. Since there are no references, borrowing rules cannot be broken.

```
use std::cell::Cell;

fn main() {
    // Note that `cell` is NOT declared as mutable.
    let cell = Cell::new(5);

    cell.set(123);
    println!("{}", cell.get());
}
```

RefCell

RefCell allows accessing and mutating a wrapped value by providing alternative types Ref and RefMut that emulate `&T` and `&mut T` without actually being Rust references.

These types perform dynamic checks using a counter in the RefCell to prevent existence of a RefMut alongside another Ref/RefMut.

By implementing Deref (and DerefMut for RefMut), these types allow calling methods on the inner value without allowing references to escape.

```
use std::cell::RefCell;

fn main() {
    // Note that `cell` is NOT declared as mutable.
    let cell = RefCell::new(5);

    {
        let mut cell_ref = cell.borrow_mut();
        *cell_ref = 123;

        // This triggers an error at runtime.
        // let other = cell.borrow();
        // println!("{}", *other);
    }

    println!("{}", cell.get());
}
```

The main thing to take away from this slide is that Rust provides *safe* ways to modify data behind a shared reference. There are a variety of ways to ensure that safety, and RefCell and Cell are two of them.

- RefCell enforces Rust's usual borrowing rules (either multiple shared references or a single exclusive reference) with a runtime check. In this case, all borrows are very short and never overlap, so the checks always succeed.
 - The extra block in the RefCell example is to end the borrow created by the call to borrow_mut before we print the cell. Trying to print a borrowed RefCell just shows the message "{borrowed}".
- Cell is a simpler means to ensure safety: it has a set method that takes &self. This needs no runtime check, but requires moving values, which can have its own cost.
- Both RefCell and Cell are !Sync, which means &RefCell and &Cell can't be passed between threads. This prevents two threads trying to access the cell at once.

22.5 Alıştırma: Sağlık İstatistikleri

You're working on implementing a health-monitoring system. As part of that, you need to keep track of users' health statistics.

You'll start with a stubbed function in an impl block as well as a User struct definition. Your goal is to implement the stubbed out method on the User struct defined in the impl block.

Copy the code below to <https://play.rust-lang.org/> and fill in the missing method:

// **TODO:** uyarlamanız (implementation) bittiğinde bu yorum satırını silin.

```
pub struct User {
    name: String,
    age: u32,
    height: f32,
    visit_count: usize,
    last_blood_pressure: Option<(u32, u32)>,
}

pub struct Measurements {
    height: f32,
    blood_pressure: (u32, u32),
}

pub struct HealthReport<'a> {
    patient_name: &'a str,
    visit_count: u32,
    height_change: f32,
    blood_pressure_change: Option<(i32, i32)>,
}

impl User {
    pub fn new(name: String, age: u32, height: f32) -> Self {
        Self { name, age, height, visit_count: 0, last_blood_pressure: None }
    }

    pub fn visit_doctor(&mut self, measurements: Measurements) -> HealthReport {
```

```

        todo!("Update a user's statistics based on measurements from a visit to the doc")
    }
}

fn main() {
    let bob = User::new(String::from("Bob"), 32, 155.2);
    println!("I'm {} and my age is {}", bob.name, bob.age);
}

fn test_visit() {
    let mut bob = User::new(String::from("Bob"), 32, 155.2);
    assert_eq!(bob.visit_count, 0);
    let report =
        bob.visit_doctor(Measurements { height: 156.1, blood_pressure: (120, 80) });
    assert_eq!(report.patient_name, "Bob");
    assert_eq!(report.visit_count, 1);
    assert_eq!(report.blood_pressure_change, None);
    assert!((report.height_change - 0.9).abs() < 0.00001);

    let report =
        bob.visit_doctor(Measurements { height: 156.1, blood_pressure: (115, 76) });

    assert_eq!(report.visit_count, 2);
    assert_eq!(report.blood_pressure_change, Some((-5, -4)));
    assert_eq!(report.height_change, 0.0);
}

```

22.5.1 Çözüm

```

pub struct User {
    name: String,
    age: u32,
    height: f32,
    visit_count: usize,
    last_blood_pressure: Option<(u32, u32)>,
}

pub struct Measurements {
    height: f32,
    blood_pressure: (u32, u32),
}

pub struct HealthReport<'a> {
    patient_name: &'a str,
    visit_count: u32,
    height_change: f32,
    blood_pressure_change: Option<(i32, i32)>,
}

impl User {

```

```

pub fn new(name: String, age: u32, height: f32) -> Self {
    Self { name, age, height, visit_count: 0, last_blood_pressure: None }
}

pub fn visit_doctor(&mut self, measurements: Measurements) -> HealthReport {
    self.visit_count += 1;
    let bp = measurements.blood_pressure;
    let report = HealthReport {
        patient_name: &self.name,
        visit_count: self.visit_count as u32,
        height_change: measurements.height - self.height,
        blood_pressure_change: match self.last_blood_pressure {
            Some(lbp) => {
                Some((bp.0 as i32 - lbp.0 as i32, bp.1 as i32 - lbp.1 as i32))
            }
            None => None,
        },
    };
    self.height = measurements.height;
    self.last_blood_pressure = Some(bp);
    report
}

fn main() {
    let bob = User::new(String::from("Bob"), 32, 155.2);
    println!("I'm {} and my age is {}", bob.name, bob.age);
}

fn test_visit() {
    let mut bob = User::new(String::from("Bob"), 32, 155.2);
    assert_eq!(bob.visit_count, 0);
    let report =
        bob.visit_doctor(Measurements { height: 156.1, blood_pressure: (120, 80) });
    assert_eq!(report.patient_name, "Bob");
    assert_eq!(report.visit_count, 1);
    assert_eq!(report.blood_pressure_change, None);
    assert!((report.height_change - 0.9).abs() < 0.00001);

    let report =
        bob.visit_doctor(Measurements { height: 156.1, blood_pressure: (115, 76) });

    assert_eq!(report.visit_count, 2);
    assert_eq!(report.blood_pressure_change, Some((-5, -4)));
    assert_eq!(report.height_change, 0.0);
}

```

Bölüm 23

Ömürler (Lifetimes)

Bu bölüm yaklaşık 50 dakika sürmelidir. İçeriği:

Slayt	Süre
Ömür için Ek Açıklamalar (Annotations)	10 dakika
Ömür Atlaması (Elision)	5 dakika
Yapıların Ömürleri	5 dakika
Alıştırma: Protobuf Ayırıştırma	30 dakika

23.1 Ömür için Ek Açıklamalar (Annotations)

A reference has a *lifetime*, which must not "outlive" the value it refers to. This is verified by the borrow checker.

The lifetime can be implicit - this is what we have seen so far. Lifetimes can also be explicit: `&'a Point`, `&'document str`. Lifetimes start with `'` and `'a` is a typical default name. Read `&'a Point` as "a borrowed `Point` which is valid for at least the lifetime `a`".

Lifetimes are always inferred by the compiler: you cannot assign a lifetime yourself. Explicit lifetime annotations create constraints where there is ambiguity; the compiler verifies that there is a valid solution.

Lifetimes become more complicated when considering passing values to and returning values from functions.

```
struct Point(i32, i32);
```

```
fn left_most(p1: &Point, p2: &Point) -> &Point {  
    if p1.0 < p2.0 {  
        p1  
    } else {  
        p2  
    }  
}
```

```

fn main() {
    let p1: Point = Point(10, 10);
    let p2: Point = Point(20, 20);
    let p3 = left_most(&p1, &p2); // What is the lifetime of p3?
    println!("p3: {p3:?}");
}

```

In this example, the compiler does not know what lifetime to infer for p3. Looking inside the function body shows that it can only safely assume that p3's lifetime is the shorter of p1 and p2. But just like types, Rust requires explicit annotations of lifetimes on function arguments and return values.

Add 'a appropriately to left_most:

```

fn left_most<'a>(p1: &'a Point, p2: &'a Point) -> &'a Point {

```

This says, "given p1 and p2 which both outlive 'a, the return value lives for at least 'a.

In common cases, lifetimes can be elided, as described on the next slide.

23.2 Fonksiyon Çağrılarında Ömürler

Lifetimes for function arguments and return values must be fully specified, but Rust allows lifetimes to be elided in most cases with **a few simple rules**. This is not inference -- it is just a syntactic shorthand.

- Each argument which does not have a lifetime annotation is given one.
- If there is only one argument lifetime, it is given to all un-annotated return values.
- If there are multiple argument lifetimes, but the first one is for self, that lifetime is given to all un-annotated return values.

```

struct Point(i32, i32);

```

```

fn cab_distance(p1: &Point, p2: &Point) -> i32 {
    (p1.0 - p2.0).abs() + (p1.1 - p2.1).abs()
}

```

```

fn nearest<'a>(points: &'a [Point], query: &Point) -> Option<&'a Point> {
    let mut nearest = None;
    for p in points {
        if let Some( (_, nearest_dist) ) = nearest {
            let dist = cab_distance(p, query);
            if dist < nearest_dist {
                nearest = Some((p, dist));
            }
        } else {
            nearest = Some((p, cab_distance(p, query)));
        }
    };
    nearest.map(|(p, _)| p)
}

```

```

fn main() {

```



```

    let points = &[Point(1, 0), Point(1, 0), Point(-1, 0), Point(0, -1)];
    println!("{:?}", nearest(points, &Point(0, 2)));
}

```

In this example, `cab_distance` is trivially elided.

The `nearest` function provides another example of a function with multiple references in its arguments that requires explicit annotation.

Try adjusting the signature to "lie" about the lifetimes returned:

```

fn nearest<'a, 'q>(points: &'a [Point], query: &'q Point) -> Option<&'q Point> {

```

This won't compile, demonstrating that the annotations are checked for validity by the compiler. Note that this is not the case for raw pointers (`unsafe`), and this is a common source of errors with `unsafe Rust`.

Students may ask when to use lifetimes. Rust borrows *always* have lifetimes. Most of the time, elision and type inference mean these don't need to be written out. In more complicated cases, lifetime annotations can help resolve ambiguity. Often, especially when prototyping, it's easier to just work with owned data by cloning values where necessary.

23.3 Veri Yapılarında Ömürler

If a data type stores borrowed data, it must be annotated with a lifetime:

```

struct Highlight<'doc>(&'doc str);

fn erase(text: String) {
    println!("Bye {text}!");
}

fn main() {
    let text = String::from("The quick brown fox jumps over the lazy dog.");
    let fox = Highlight(&text[4..19]);
    let dog = Highlight(&text[35..43]);
    // erase(text);
    println!("{fox:?}");
    println!("{dog:?}");
}

```

- In the above example, the annotation on `Highlight` enforces that the data underlying the contained `&str` lives at least as long as any instance of `Highlight` that uses that data.
- If `text` is consumed before the end of the lifetime of `fox` (or `dog`), the borrow checker throws an error.
- Types with borrowed data force users to hold on to the original data. This can be useful for creating lightweight views, but it generally makes them somewhat harder to use.
- When possible, make data structures own their data directly.
- Some structs with multiple references inside can have more than one lifetime annotation. This can be necessary if there is a need to describe lifetime relationships between the references themselves, in addition to the lifetime of the struct itself. Those are very advanced use cases.

23.4 Alıştırma: Protobuf Ayırıştırma

In this exercise, you will build a parser for the **protobuf binary encoding**. Don't worry, it's simpler than it seems! This illustrates a common parsing pattern, passing slices of data. The underlying data itself is never copied.

Fully parsing a protobuf message requires knowing the types of the fields, indexed by their field numbers. That is typically provided in a proto file. In this exercise, we'll encode that information into match statements in functions that get called for each field.

We'll use the following proto:

```
message PhoneNumber {
    optional string number = 1;
    optional string type = 2;
}

message Person {
    optional string name = 1;
    optional int32 id = 2;
    repeated PhoneNumber phones = 3;
}
```

Messages

A proto message is encoded as a series of fields, one after the next. Each is implemented as a "tag" followed by the value. The tag contains a field number (e.g., 2 for the `id` field of a `Person` message) and a wire type defining how the payload should be determined from the byte stream. These are combined into a single integer, as decoded in `unpack_tag` below.

Varint

Integers, including the tag, are represented with a variable-length encoding called VARINT. Luckily, `parse_varint` is defined for you below.

Wire Types

Proto defines several wire types, only two of which are used in this exercise.

The Varint wire type contains a single varint, and is used to encode proto values of type `int32` such as `Person.id`.

The Len wire type contains a length expressed as a varint, followed by a payload of that number of bytes. This is used to encode proto values of type `string` such as `Person.name`. It is also used to encode proto values containing sub-messages such as `Person.phones`, where the payload contains an encoding of the sub-message.

Alıştırma

The given code also defines callbacks to handle `Person` and `PhoneNumber` fields, and to parse a message into a series of calls to those callbacks.

What remains for you is to implement the `parse_field` function and the `ProtoMessage` trait for `Person` and `PhoneNumber`.

```
/// A wire type as seen on the wire.
enum WireType {
    /// The Varint WireType indicates the value is a single VARINT.
    Varint,
    /// The I64 WireType indicates that the value is precisely 8 bytes in
    /// little-endian order containing a 64-bit signed integer or double type.
    ///I64, -- not needed for this exercise
    /// The Len WireType indicates that the value is a length represented as a
    /// VARINT followed by exactly that number of bytes.
    Len,
    /// The I32 WireType indicates that the value is precisely 4 bytes in
    /// little-endian order containing a 32-bit signed integer or float type.
    ///I32, -- not needed for this exercise
}

/// A field's value, typed based on the wire type.
enum FieldValue<'a> {
    Varint(u64),
    ///I64(i64), -- not needed for this exercise
    Len(&'a [u8]),
    ///I32(i32), -- not needed for this exercise
}

/// A field, containing the field number and its value.
struct Field<'a> {
    field_num: u64,
    value: FieldValue<'a>,
}

trait ProtoMessage<'a>: Default {
    fn add_field(&mut self, field: Field<'a>);
}

impl From<u64> for WireType {
    fn from(value: u64) -> Self {
        match value {
            0 => WireType::Varint,
            //1 => WireType::I64, -- not needed for this exercise
            2 => WireType::Len,
            //5 => WireType::I32, -- not needed for this exercise
            _ => panic!("Invalid wire type: {value}"),
        }
    }
}

impl<'a> FieldValue<'a> {
    fn as_str(&self) -> &'a str {
        let FieldValue::Len(data) = self else {

```

```

        panic!("Expected string to be a `Len` field");
    };
    std::str::from_utf8(data).expect("Invalid string")
}

fn as_bytes(&self) -> &'a [u8] {
    let FieldValue::Len(data) = self else {
        panic!("Expected bytes to be a `Len` field");
    };
    data
}

fn as_u64(&self) -> u64 {
    let FieldValue::Varint(value) = self else {
        panic!("Expected `u64` to be a `Varint` field");
    };
    *value
}
}

/// Parse a VARINT, returning the parsed value and the remaining bytes.
fn parse_varint(data: &[u8]) -> (u64, &[u8]) {
    for i in 0..7 {
        let Some(b) = data.get(i) else {
            panic!("Not enough bytes for varint");
        };
        if b & 0x80 == 0 {
            // This is the last byte of the VARINT, so convert it to
            // a u64 and return it.
            let mut value = 0u64;
            for b in data[..i].iter().rev() {
                value = (value << 7) | (b & 0x7f) as u64;
            }
            return (value, &data[i + 1..]);
        }
    }

    // More than 7 bytes is invalid.
    panic!("Too many bytes for varint");
}

/// Convert a tag into a field number and a WireType.
fn unpack_tag(tag: u64) -> (u64, WireType) {
    let field_num = tag >> 3;
    let wire_type = WireType::from(tag & 0x7);
    (field_num, wire_type)
}

/// Parse a field, returning the remaining bytes
fn parse_field(data: &[u8]) -> (Field, &[u8]) {

```

```

    let (tag, remainder) = parse_varint(data);
    let (field_num, wire_type) = unpack_tag(tag);
    let (fieldvalue, remainder) = match wire_type {
        _ => todo!("Based on the wire type, build a Field, consuming as many bytes as needed.");
    };
    todo!("Return the field, and any un-consumed bytes.")
}

/// Parse a message in the given data, calling `T::add_field` for each field in
/// the message.
///
/// The entire input is consumed.
fn parse_message<'a, T: ProtoMessage<'a>>(mut data: &'a [u8]) -> T {
    let mut result = T::default();
    while !data.is_empty() {
        let parsed = parse_field(data);
        result.add_field(parsed.0);
        data = parsed.1;
    }
    result
}

struct PhoneNumber<'a> {
    number: &'a str,
    type_: &'a str,
}

struct Person<'a> {
    name: &'a str,
    id: u64,
    phone: Vec<PhoneNumber<'a>>,
}

// TODO: Implement ProtoMessage for Person and PhoneNumber.

fn main() {
    let person_id: Person = parse_message(&[0x10, 0x2a]);
    assert_eq!(person_id, Person { name: "", id: 42, phone: vec![] });

    let person_name: Person = parse_message(&[
        0x0a, 0x0e, 0x62, 0x65, 0x61, 0x75, 0x74, 0x69, 0x66, 0x75, 0x6c, 0x20,
        0x6e, 0x61, 0x6d, 0x65,
    ]);
    assert_eq!(person_name, Person { name: "beautiful name", id: 0, phone: vec![] });

    let person_name_id: Person =
        parse_message(&[0x0a, 0x04, 0x45, 0x76, 0x61, 0x6e, 0x10, 0x16]);
    assert_eq!(person_name_id, Person { name: "Evan", id: 22, phone: vec![] });

    let phone: Person = parse_message(&[
        0x0a, 0x00, 0x10, 0x00, 0x1a, 0x16, 0x0a, 0x0e, 0x2b, 0x31, 0x32, 0x33,
    ]);
}

```

```

    0x34, 0x2d, 0x37, 0x37, 0x37, 0x2d, 0x39, 0x30, 0x39, 0x30, 0x12, 0x04,
    0x68, 0x6f, 0x6d, 0x65,
]);
assert_eq!(
    phone,
    Person {
        name: "",
        id: 0,
        phone: vec![PhoneNumber { number: "+1234-777-9090", type_: "home" },],
    }
);

// Put that all together into a single parse.
let person: Person = parse_message(&[
    0x0a, 0x07, 0x6d, 0x61, 0x78, 0x77, 0x65, 0x6c, 0x6c, 0x10, 0x2a, 0x1a,
    0x16, 0x0a, 0x0e, 0x2b, 0x31, 0x32, 0x30, 0x32, 0x2d, 0x35, 0x35, 0x35,
    0x2d, 0x31, 0x32, 0x31, 0x32, 0x12, 0x04, 0x68, 0x6f, 0x6d, 0x65, 0x1a,
    0x18, 0x0a, 0x0e, 0x2b, 0x31, 0x38, 0x30, 0x30, 0x2d, 0x38, 0x36, 0x37,
    0x2d, 0x35, 0x33, 0x30, 0x38, 0x12, 0x06, 0x6d, 0x6f, 0x62, 0x69, 0x6c,
    0x65,
]);
assert_eq!(
    person,
    Person {
        name: "maxwell",
        id: 42,
        phone: vec![
            PhoneNumber { number: "+1202-555-1212", type_: "home" },
            PhoneNumber { number: "+1800-867-5308", type_: "mobile" },
        ]
    }
);
}

```

- In this exercise there are various cases where protobuf parsing might fail, e.g. if you try to parse an i32 when there are fewer than 4 bytes left in the data buffer. In normal Rust code we'd handle this with the Result enum, but for simplicity in this exercise we panic if any errors are encountered. On day 4 we'll cover error handling in Rust in more detail.

23.4.1 Çözüm

```

/// A wire type as seen on the wire.
enum WireType {
    /// The Varint WireType indicates the value is a single VARINT.
    Varint,
    /// The I64 WireType indicates that the value is precisely 8 bytes in
    /// little-endian order containing a 64-bit signed integer or double type.
    ///I64, -- not needed for this exercise
    /// The Len WireType indicates that the value is a length represented as a
    /// VARINT followed by exactly that number of bytes.

```

```

    Len,
    // The I32 wireType indicates that the value is precisely 4 bytes in
    // little-endian order containing a 32-bit signed integer or float type.
    //I32, -- not needed for this exercise
}

/// A field's value, typed based on the wire type.
enum FieldValue<'a> {
    Varint(u64),
    //I64(i64), -- not needed for this exercise
    Len(&'a [u8]),
    //I32(i32), -- not needed for this exercise
}

/// A field, containing the field number and its value.
struct Field<'a> {
    field_num: u64,
    value: FieldValue<'a>,
}

trait ProtoMessage<'a>: Default {
    fn add_field(&mut self, field: Field<'a>);
}

impl From<u64> for WireType {
    fn from(value: u64) -> Self {
        match value {
            0 => WireType::Varint,
            //1 => WireType::I64, -- not needed for this exercise
            2 => WireType::Len,
            //5 => WireType::I32, -- not needed for this exercise
            _ => panic!("Invalid wire type: {value}"),
        }
    }
}

impl<'a> FieldValue<'a> {
    fn as_str(&self) -> &'a str {
        let FieldValue::Len(data) = self else {
            panic!("Expected string to be a `Len` field");
        };
        std::str::from_utf8(data).expect("Invalid string")
    }

    fn as_bytes(&self) -> &'a [u8] {
        let FieldValue::Len(data) = self else {
            panic!("Expected bytes to be a `Len` field");
        };
        data
    }
}

```

```

fn as_u64(&self) -> u64 {
    let fieldValue: Varint(value) = self else {
        panic!("Expected `u64` to be a `Varint` field");
    };
    *value
}

}

/// Parse a VARINT, returning the parsed value and the remaining bytes.
fn parse_varint(data: &[u8]) -> (u64, &[u8]) {
    for i in 0..7 {
        let Some(b) = data.get(i) else {
            panic!("Not enough bytes for varint");
        };
        if b & 0x80 == 0 {
            // This is the last byte of the VARINT, so convert it to
            // a u64 and return it.
            let mut value = 0u64;
            for b in data[..i].iter().rev() {
                value = (value << 7) | (b & 0x7f) as u64;
            }
            return (value, &data[i + 1..]);
        }
    }

    // More than 7 bytes is invalid.
    panic!("Too many bytes for varint");
}

/// Convert a tag into a field number and a WireType.
fn unpack_tag(tag: u64) -> (u64, WireType) {
    let field_num = tag >> 3;
    let wire_type = WireType::from(tag & 0x7);
    (field_num, wire_type)
}

/// Parse a field, returning the remaining bytes
fn parse_field(data: &[u8]) -> (Field, &[u8]) {
    let (tag, remainder) = parse_varint(data);
    let (field_num, wire_type) = unpack_tag(tag);
    let (fieldvalue, remainder) = match wire_type {
        WireType::Varint => {
            let (value, remainder) = parse_varint(remainder);
            (FieldValue::Varint(value), remainder)
        }
        WireType::Len => {
            let (len, remainder) = parse_varint(remainder);
            let len: usize = len.try_into().expect("len not a valid `usize`");
            if remainder.len() < len {
                panic!("Unexpected EOF");
            }
        }
    }
}

```



```

        let (value, remainder) = remainder.split_at(len);
        (FieldValue::Len(value), remainder)
    }
};
(Field { field_num, value: fieldvalue }, remainder)
}

/// Parse a message in the given data, calling `T::add_field` for each field in
/// the message.
///
/// The entire input is consumed.
fn parse_message<'a, T: ProtoMessage<'a>>(mut data: &'a [u8]) -> T {
    let mut result = T::default();
    while !data.is_empty() {
        let parsed = parse_field(data);
        result.add_field(parsed.0);
        data = parsed.1;
    }
    result
}

struct PhoneNumber<'a> {
    number: &'a str,
    type_: &'a str,
}

struct Person<'a> {
    name: &'a str,
    id: u64,
    phone: Vec<PhoneNumber<'a>>,
}

impl<'a> ProtoMessage<'a> for Person<'a> {
    fn add_field(&mut self, field: Field<'a>) {
        match field.field_num {
            1 => self.name = field.value.as_str(),
            2 => self.id = field.value.as_u64(),
            3 => self.phone.push(parse_message(field.value.as_bytes())),
            _ => {} // skip everything else
        }
    }
}

impl<'a> ProtoMessage<'a> for PhoneNumber<'a> {
    fn add_field(&mut self, field: Field<'a>) {
        match field.field_num {
            1 => self.number = field.value.as_str(),
            2 => self.type_ = field.value.as_str(),
            _ => {} // skip everything else
        }
    }
}

```

```

}

fn main() {
  let person_id: Person = parse_message(&[0x10, 0x2a]);
  assert_eq!(person_id, Person { name: "", id: 42, phone: vec![] });

  let person_name: Person = parse_message(&[
    0x0a, 0x0e, 0x62, 0x65, 0x61, 0x75, 0x74, 0x69, 0x66, 0x75, 0x6c, 0x20,
    0x6e, 0x61, 0x6d, 0x65,
  ]);
  assert_eq!(person_name, Person { name: "beautiful name", id: 0, phone: vec![] });

  let person_name_id: Person =
    parse_message(&[0x0a, 0x04, 0x45, 0x76, 0x61, 0x6e, 0x10, 0x16]);
  assert_eq!(person_name_id, Person { name: "Evan", id: 22, phone: vec![] });

  let phone: Person = parse_message(&[
    0x0a, 0x00, 0x10, 0x00, 0x1a, 0x16, 0x0a, 0x0e, 0x2b, 0x31, 0x32, 0x33,
    0x34, 0x2d, 0x37, 0x37, 0x37, 0x2d, 0x39, 0x30, 0x39, 0x30, 0x12, 0x04,
    0x68, 0x6f, 0x6d, 0x65,
  ]);
  assert_eq!(
    phone,
    Person {
      name: "",
      id: 0,
      phone: vec![PhoneNumber { number: "+1234-777-9090", type_: "home" },],
    }
  );

  // Put that all together into a single parse.
  let person: Person = parse_message(&[
    0x0a, 0x07, 0x6d, 0x61, 0x78, 0x77, 0x65, 0x6c, 0x6c, 0x10, 0x2a, 0x1a,
    0x16, 0x0a, 0x0e, 0x2b, 0x31, 0x32, 0x30, 0x32, 0x2d, 0x35, 0x35, 0x35,
    0x2d, 0x31, 0x32, 0x31, 0x32, 0x12, 0x04, 0x68, 0x6f, 0x6d, 0x65, 0x1a,
    0x18, 0x0a, 0x0e, 0x2b, 0x31, 0x38, 0x30, 0x30, 0x2d, 0x38, 0x36, 0x37,
    0x2d, 0x35, 0x33, 0x30, 0x38, 0x12, 0x06, 0x6d, 0x6f, 0x62, 0x69, 0x6c,
    0x65,
  ]);
  assert_eq!(
    person,
    Person {
      name: "maxwell",
      id: 42,
      phone: vec![
        PhoneNumber { number: "+1202-555-1212", type_: "home" },
        PhoneNumber { number: "+1800-867-5308", type_: "mobile" },
      ]
    }
  );
}

```

Kısım VII

Gün 4: Sabah

Bölüm 24

4. Gün'e Hoş Geldiniz

Today we will cover topics relating to building large-scale software in Rust:

- Iterators: a deep dive on the `Iterator` trait.
- Modules and visibility.
- Testing.
- Error handling: panics, `Result`, and the `try` operator ?.
- Unsafe Rust: the escape hatch when you can't express yourself in safe Rust.

Zamanlama (Schedule)

Bu oturum 10 dakikalık aralar dahil yaklaşık 2 saat 40 dakika sürmelidir. İçeriği:

Bölüm	Süre
Hoş Geldiniz	3 dakika
Adımlayıcılar (Iterators)	45 dakika
Modüller	40 dakika
Test Etme	45 dakika

Bölüm 25

Adımlayıcılar (Iterators)

Bu bölüm yaklaşık 45 dakika sürmelidir. İçeriği:

Slayt	Süre
Iterator	5 dakika
IntoIterator	5 dakika
FromIterator	5 dakika
Alıştırma: Adımlayıcı Metot Zincirleme	30 dakika

25.1 Iterator

The `Iterator` trait supports iterating over values in a collection. It requires a `next` method and provides lots of methods. Many standard library types implement `Iterator`, and you can implement it yourself, too:

```
struct Fibonacci {
    curr: u32,
    next: u32,
}

impl Iterator for Fibonacci {
    type Item = u32;

    fn next(&mut self) -> Option<Self::Item> {
        let new_next = self.curr + self.next;
        self.curr = self.next;
        self.next = new_next;
        Some(self.curr)
    }
}

fn main() {
    let fib = Fibonacci { curr: 0, next: 1 };
    for (i, n) in fib.enumerate().take(5) {
```

```

        println!("fib({i}): {n}");
    }
}

```

- The `Iterator` trait implements many common functional programming operations over collections (e.g. `map`, `filter`, `reduce`, etc). This is the trait where you can find all the documentation about them. In Rust these functions should produce the code as efficient as equivalent imperative implementations.
- `IntoIterator` is the trait that makes for loops work. It is implemented by collection types such as `Vec<T>` and references to them such as `&Vec<T>` and `&[T]`. Ranges also implement it. This is why you can iterate over a vector with `for i in some_vec { .. }` but `some_vec.next()` doesn't exist.

25.2 IntoIterator

The `Iterator` trait tells you how to *iterate* once you have created an iterator. The related trait `IntoIterator` defines how to create an iterator for a type. It is used automatically by the `for` loop.

```

struct Grid {
    x_coords: Vec<u32>,
    y_coords: Vec<u32>,
}

impl IntoIterator for Grid {
    type Item = (u32, u32);
    type IntoIter = GridIter;
    fn into_iter(self) -> GridIter {
        GridIter { grid: self, i: 0, j: 0 }
    }
}

struct GridIter {
    grid: Grid,
    i: usize,
    j: usize,
}

impl Iterator for GridIter {
    type Item = (u32, u32);

    fn next(&mut self) -> Option<(u32, u32)> {
        if self.i >= self.grid.x_coords.len() {
            self.i = 0;
            self.j += 1;
            if self.j >= self.grid.y_coords.len() {
                return None;
            }
        }
        let res = Some((self.grid.x_coords[self.i], self.grid.y_coords[self.j]));
    }
}

```

```

        self.i += 1;
        res
    }
}

fn main() {
    let grid = Grid { x_coords: vec![3, 5, 7, 9], y_coords: vec![10, 20, 30, 40] };
    for (x, y) in grid {
        println!("point = {x}, {y}");
    }
}

```

Click through to the docs for `IntoIterator`. Every implementation of `IntoIterator` must declare two types:

- `Item`: the type to iterate over, such as `i8`,
- `IntoIter`: the `Iterator` type returned by the `into_iter` method.

Note that `IntoIter` and `Item` are linked: the iterator must have the same `Item` type, which means that it returns `Option<Item>`

The example iterates over all combinations of `x` and `y` coordinates.

Try iterating over the grid twice in `main`. Why does this fail? Note that `IntoIterator::into_iter` takes ownership of `self`.

Fix this issue by implementing `IntoIterator` for `&Grid` and storing a reference to the `Grid` in `GridIter`.

The same problem can occur for standard library types: `for e in some_vector` will take ownership of `some_vector` and iterate over owned elements from that vector. Use `for e in &some_vector` instead, to iterate over references to elements of `some_vector`.

25.3 FromIterator

`FromIterator` lets you build a collection from an `Iterator`.

```

fn main() {
    let primes = vec![2, 3, 5, 7];
    let prime_squares = primes.into_iter().map(|p| p * p).collect::<Vec<_>>();
    println!("prime_squares: {prime_squares:?}");
}

```

`Iterator` implements

```

fn collect<B>(self) -> B
where
    B: FromIterator<Self::Item>,
    Self: Sized

```

There are two ways to specify `B` for this method:

- With the "turbofish": `some_iterator.collect::<COLLECTION_TYPE>()`, as shown. The `_` shorthand used here lets Rust infer the type of the `Vec` elements.
- With type inference: `let prime_squares: Vec<_> = some_iterator.collect()`. Rewrite the example to use this form.

There are basic implementations of `FromIterator` for `Vec`, `HashMap`, etc. There are also more specialized implementations which let you do cool things like convert an `Iterator<Item> = Result<V, E>` into a `Result<Vec<V>, E>`.

25.4 Alıştırma: Adımlayıcı Metot Zincirleme

In this exercise, you will need to find and use some of the provided methods in the `Iterator` trait to implement a complex calculation.

Copy the following code to <https://play.rust-lang.org/> and make the tests pass. Use an iterator expression and collect the result to construct the return value.

```
/// Calculate the differences between elements of `values` offset by `offset`,
/// wrapping around from the end of `values` to the beginning.
///
/// Element `n` of the result is `values[(n+offset)%len] - values[n]`.
fn offset_differences(offset: usize, values: Vec<i32>) -> Vec<i32> {
    unimplemented!()
}

fn test_offset_one() {
    assert_eq!(offset_differences(1, vec![1, 3, 5, 7]), vec![2, 2, 2, -6]);
    assert_eq!(offset_differences(1, vec![1, 3, 5]), vec![2, 2, -4]);
    assert_eq!(offset_differences(1, vec![1, 3]), vec![2, -2]);
}

fn test_larger_offsets() {
    assert_eq!(offset_differences(2, vec![1, 3, 5, 7]), vec![4, 4, -4, -4]);
    assert_eq!(offset_differences(3, vec![1, 3, 5, 7]), vec![6, -2, -2, -2]);
    assert_eq!(offset_differences(4, vec![1, 3, 5, 7]), vec![0, 0, 0, 0]);
    assert_eq!(offset_differences(5, vec![1, 3, 5, 7]), vec![2, 2, 2, -6]);
}

fn test_degenerate_cases() {
    assert_eq!(offset_differences(1, vec![0]), vec![0]);
    assert_eq!(offset_differences(1, vec![1]), vec![0]);
    let empty: Vec<i32> = vec![];
    assert_eq!(offset_differences(1, empty), vec![]);
}
```

25.4.1 Çözüm

```
/// Calculate the differences between elements of `values` offset by `offset`,
/// wrapping around from the end of `values` to the beginning.
///
/// Element `n` of the result is `values[(n+offset)%len] - values[n]`.
fn offset_differences(offset: usize, values: Vec<i32>) -> Vec<i32> {
    let a = (&values).into_iter();
    let b = (&values).into_iter().cycle().skip(offset);
    a.zip(b).map(|(a, b)| *b - *a).collect()
}
```



```

fn test_offset_one() {
    assert_eq!(offset_differences(1, vec![1, 3, 5, 7]), vec![2, 2, 2, -6]);
    assert_eq!(offset_differences(1, vec![1, 3, 5]), vec![2, 2, -4]);
    assert_eq!(offset_differences(1, vec![1, 3]), vec![2, -2]);
}

fn test_larger_offsets() {
    assert_eq!(offset_differences(2, vec![1, 3, 5, 7]), vec![4, 4, -4, -4]);
    assert_eq!(offset_differences(3, vec![1, 3, 5, 7]), vec![6, -2, -2, -2]);
    assert_eq!(offset_differences(4, vec![1, 3, 5, 7]), vec![0, 0, 0, 0]);
    assert_eq!(offset_differences(5, vec![1, 3, 5, 7]), vec![2, 2, 2, -6]);
}

fn test_degenerate_cases() {
    assert_eq!(offset_differences(1, vec![0]), vec![0]);
    assert_eq!(offset_differences(1, vec![1]), vec![0]);
    let empty: Vec<i32> = vec![];
    assert_eq!(offset_differences(1, empty), vec![]);
}

fn main() {}

```

Bölüm 26

Modüller

Bu bölüm yaklaşık 40 dakika sürmelidir. İçeriği:

Slayt	Süre
Modüller	3 dakika
Dosya Sistemi Hiyerarşisi	5 dakika
Görünürlük	5 dakika
use, super, self	10 dakika
Alıştırma: Bir GUI Kütüphanesi için Modüller	15 dakika

26.1 Modüller

We have seen how `impl` blocks let us namespace functions to a type.

Similarly, `mod` lets us namespace types and functions:

```
mod foo {
    pub fn do_something() {
        println!("In the foo module");
    }
}

mod bar {
    pub fn do_something() {
        println!("In the bar module");
    }
}

fn main() {
    foo::do_something();
    bar::do_something();
}
```

- Packages provide functionality and include a `Cargo.toml` file that describes how to build a bundle of 1+ crates.

- Crates are a tree of modules, where a binary crate creates an executable and a library crate compiles to a library.
- Modules define organization, scope, and are the focus of this section.

26.2 Dosya Sistemi Hiyerarşisi

Omitting the module content will tell Rust to look for it in another file:

```
mod garden;
```

This tells Rust that the garden module content is found at `src/garden.rs`. Similarly, a `garden::vegetables` module can be found at `src/garden/vegetables.rs`.

The crate root is in:

- `src/lib.rs` (for a library crate)
- `src/main.rs` (for a binary crate)

Modules defined in files can be documented, too, using "inner doc comments". These document the item that contains them -- in this case, a module.

```
/// This module implements the garden, including a highly performant germination
/// implementation.
```

```
// Re-export types from this module.
```

```
pub use garden::Garden;
pub use seeds::SeedPacket;
```

```
/// Sow the given seed packets.
```

```
pub fn sow(seeds: Vec<SeedPacket>) {
    todo!()
}
```

```
/// Harvest the produce in the garden that is ready.
```

```
pub fn harvest(garden: &mut Garden) {
    todo!()
}
```

- Before Rust 2018, modules needed to be located at `module/mod.rs` instead of `module.rs`, and this is still a working alternative for editions after 2018.
- The main reason to introduce `filename.rs` as alternative to `filename/mod.rs` was because many files named `mod.rs` can be hard to distinguish in IDEs.
- Deeper nesting can use folders, even if the main module is a file:

```
src/
├── main.rs
├── top_module.rs
├── top_module/
│   └── sub_module.rs
```

- The place rust will look for modules can be changed with a compiler directive:

```
mod some_module;
```

This is useful, for example, if you would like to place tests for a module in a file named `some_module_test.rs`, similar to the convention in Go.

26.3 Görünürlük

Modules are a privacy boundary:

- Module items are private by default (hides implementation details).
- Parent and sibling items are always visible.
- In other words, if an item is visible in module `foo`, it's visible in all the descendants of `foo`.

```
mod outer {
    fn private() {
        println!("outer::private");
    }

    pub fn public() {
        println!("outer::public");
    }
}

mod inner {
    fn private() {
        println!("outer::inner::private");
    }

    pub fn public() {
        println!("outer::inner::public");
        super::private();
    }
}

fn main() {
    outer::public();
}
```

- Use the `pub` keyword to make modules public.

Additionally, there are advanced `pub(. . .)` specifiers to restrict the scope of public visibility.

- See the [Rust Reference](#).
- Configuring `pub(crate)` visibility is a common pattern.
- Less commonly, you can give visibility to a specific path.
- In any case, visibility must be granted to an ancestor module (and all of its descendants).

26.4 use, super, self

A module can bring symbols from another module into scope with `use`. You will typically see something like this at the top of each module:

```
use std::collections::HashSet;
use std::process::abort;
```

Yollar (Paths)

Paths are resolved as follows:

1. As a relative path:
 - `foo` or `self::foo` refers to `foo` in the current module,
 - `super::foo` refers to `foo` in the parent module.
 2. As an absolute path:
 - `crate::foo` refers to `foo` in the root of the current crate,
 - `bar::foo` refers to `foo` in the `bar` crate.
- It is common to "re-export" symbols at a shorter path. For example, the top-level `lib.rs` in a crate might have

```
mod storage;
```

```
pub use storage::disk::DiskStorage;
pub use storage::network::NetworkStorage;
```

making `DiskStorage` and `NetworkStorage` available to other crates with a convenient, short path.

- For the most part, only items that appear in a module need to be use'd. However, a trait must be in scope to call any methods on that trait, even if a type implementing that trait is already in scope. For example, to use the `read_to_string` method on a type implementing the `Read` trait, you need to use `std::io::Read`.
- The `use` statement can have a wildcard: `use std::io::*`. This is discouraged because it is not clear which items are imported, and those might change over time.

26.5 Alıştırma: Bir GUI Kütüphanesi için Modüller

In this exercise, you will reorganize a small GUI Library implementation. This library defines a `Widget` trait and a few implementations of that trait, as well as a `main` function.

It is typical to put each type or set of closely-related types into its own module, so each widget type should get its own module.

Cargo Kurulumu (Setup)

The Rust playground only supports one file, so you will need to make a Cargo project on your local filesystem:

```
cargo init gui-modules
cd gui-modules
cargo run
```

Edit the resulting `src/main.rs` to add `mod` statements, and add additional files in the `src` directory.

Source

Here's the single-module implementation of the GUI library:

```
pub trait Widget {
    /// Natural width of `self`.
    fn width(&self) -> usize;

    /// Draw the widget into a buffer.
    fn draw_into(&self, buffer: &mut dyn std::fmt::Write);

    /// Draw the widget on standard output.
    fn draw(&self) {
        let mut buffer = String::new();
        self.draw_into(&mut buffer);
        println!("{}", buffer);
    }
}

pub struct Label {
    label: String,
}

impl Label {
    fn new(label: &str) -> Label {
        Label { label: label.to_owned() }
    }
}

pub struct Button {
    label: Label,
}

impl Button {
    fn new(label: &str) -> Button {
        Button { label: Label::new(label) }
    }
}

pub struct Window {
    title: String,
    widgets: Vec<Box<dyn Widget>>,
}

impl Window {
    fn new(title: &str) -> Window {
        Window { title: title.to_owned(), widgets: Vec::new() }
    }

    fn add_widget(&mut self, widget: Box<dyn Widget>) {
        self.widgets.push(widget);
    }
}
```

```

fn inner_width(&self) -> usize {
    std::cmp::max(
        self.title.chars().count(),
        self.widgets.iter().map(|w| w.width()).max().unwrap_or(0),
    )
}

impl Widget for Window {
    fn width(&self) -> usize {
        // Add 4 paddings for borders
        self.inner_width() + 4
    }

    fn draw_into(&self, buffer: &mut dyn std::fmt::Write) {
        let mut inner = String::new();
        for widget in &self.widgets {
            widget.draw_into(&mut inner);
        }

        let inner_width = self.inner_width();

        // TODO: Change draw_into to return Result<(), std::fmt::Error>. Then use the
        // ?-operator here instead of .unwrap().
        writeln!(buffer, "+-{:~<inner_width$}-+", "").unwrap();
        writeln!(buffer, "| {:^inner_width$} |", &self.title).unwrap();
        writeln!(buffer, "+={:~<inner_width$}=+", "").unwrap();
        for line in inner.lines() {
            writeln!(buffer, "| {:inner_width$} |", line).unwrap();
        }
        writeln!(buffer, "+-{:~<inner_width$}-+", "").unwrap();
    }
}

impl Widget for Button {
    fn width(&self) -> usize {
        self.label.width() + 8 // add a bit of padding
    }

    fn draw_into(&self, buffer: &mut dyn std::fmt::Write) {
        let width = self.width();
        let mut label = String::new();
        self.label.draw_into(&mut label);

        writeln!(buffer, "+{:~<width$}+", "").unwrap();
        for line in label.lines() {
            writeln!(buffer, "|{:~^width$}|", &line).unwrap();
        }
        writeln!(buffer, "+{:~<width$}+", "").unwrap();
    }
}

```

```

}

impl Widget for Label {
    fn width(&self) -> usize {
        self.label.lines().map(|line| line.chars().count()).max().unwrap_or(0)
    }

    fn draw_into(&self, buffer: &mut dyn std::fmt::Write) {
        writeln!(buffer, "{}", &self.label).unwrap();
    }
}

fn main() {
    let mut window = Window::new("Rust GUI Demo 1.23");
    window.add_widget(Box::new(Label::new("This is a small text GUI demo.")));
    window.add_widget(Box::new(Button::new("Click me!")));
    window.draw();
}

```

Encourage students to divide the code in a way that feels natural for them, and get accustomed to the required `mod`, `use`, and `pub` declarations. Afterward, discuss what organizations are most idiomatic.

26.5.1 Çözüm

```

src
├── main.rs
├── widgets
│   ├── button.rs
│   ├── label.rs
│   └── window.rs
└── widgets.rs

// ---- src/widgets.rs ----
mod button;
mod label;
mod window;

pub trait Widget {
    /// Natural width of `self`.
    fn width(&self) -> usize;

    /// Draw the widget into a buffer.
    fn draw_into(&self, buffer: &mut dyn std::fmt::Write);

    /// Draw the widget on standard output.
    fn draw(&self) {
        let mut buffer = String::new();
        self.draw_into(&mut buffer);
        println!("{}", buffer);
    }
}

```



```

}

pub use button::Button;
pub use label::Label;
pub use window::Window;

// ---- src/widgets/label.rs ----
use super::Widget;

pub struct Label {
    label: String,
}

impl Label {
    pub fn new(label: &str) -> Label {
        Label { label: label.to_owned() }
    }
}

impl Widget for Label {
    fn width(&self) -> usize {
        // ANCHOR_END: Label-width
        self.label.lines().map(|line| line.chars().count()).max().unwrap_or(0)
    }

    // ANCHOR: Label-draw_into
    fn draw_into(&self, buffer: &mut dyn std::fmt::Write) {
        // ANCHOR_END: Label-draw_into
        writeln!(buffer, "{}", &self.label).unwrap();
    }
}

// ---- src/widgets/button.rs ----
use super::{Label, Widget};

pub struct Button {
    label: Label,
}

impl Button {
    pub fn new(label: &str) -> Button {
        Button { label: Label::new(label) }
    }
}

impl Widget for Button {
    fn width(&self) -> usize {
        // ANCHOR_END: Button-width
        self.label.width() + 8 // add a bit of padding
    }

    // ANCHOR: Button-draw_into

```

```

fn draw_into(&self, buffer: &mut dyn std::fmt::Write) {
    // ANCHOR_END: Button-draw_into
    let width = self.width();
    let mut label = String::new();
    self.label.draw_into(&mut label);

    writeln!(buffer, "+{:<width$}+", "").unwrap();
    for line in label.lines() {
        writeln!(buffer, "|{:<width$}|", &line).unwrap();
    }
    writeln!(buffer, "+{:<width$}+", "").unwrap();
}
}

// ---- src/widgets/window.rs ----
use super::Widget;

pub struct Window {
    title: String,
    widgets: Vec<Box<dyn Widget>>,
}

impl Window {
    pub fn new(title: &str) -> Window {
        Window { title: title.to_owned(), widgets: Vec::new() }
    }

    pub fn add_widget(&mut self, widget: Box<dyn Widget>) {
        self.widgets.push(widget);
    }

    fn inner_width(&self) -> usize {
        std::cmp::max(
            self.title.chars().count(),
            self.widgets.iter().map(|w| w.width()).max().unwrap_or(0),
        )
    }
}

impl Widget for Window {
    fn width(&self) -> usize {
        // ANCHOR_END: Window-width
        // Add 4 paddings for borders
        self.inner_width() + 4
    }

    // ANCHOR: Window-draw_into
    fn draw_into(&self, buffer: &mut dyn std::fmt::Write) {
        // ANCHOR_END: Window-draw_into
        let mut inner = String::new();
        for widget in &self.widgets {

```

```

        widget.draw_into(&mut inner);
    }

    let inner_width = self.inner_width();

    // TODO: after learning about error handling, you can change
    // draw_into to return Result<(), std::fmt::Error>. Then use
    // the ?-operator here instead of .unwrap().
    writeln!(buffer, "+-{:~<inner_width$}-+", "").unwrap();
    writeln!(buffer, "| {:^inner_width$} |", &self.title).unwrap();
    writeln!(buffer, "+={:~<inner_width$}=+", "").unwrap();
    for line in inner.lines() {
        writeln!(buffer, "| {:inner_width$} |", line).unwrap();
    }
    writeln!(buffer, "+-{:~<inner_width$}-+", "").unwrap();
}
}

// ---- src/main.rs ----
mod widgets;

use widgets::Widget;

fn main() {
    let mut window = widgets::Window::new("Rust GUI Demo 1.23");
    window
        .add_widget(Box::new(widgets::Label::new("This is a small text GUI demo.")));
    window.add_widget(Box::new(widgets::Button::new("Click me!")));
    window.draw();
}

```

Bölüm 27

Test Etme

Bu bölüm yaklaşık 45 dakika sürmelidir. İçeriği:

Slayt	Süre
Test Modülleri	5 dakika
Diğer Test Türleri	5 dakika
Derleyici Tüyleri (Lint) ve Clippy Aracı	3 dakika
Alıştırma: Luhn Algoritması	30 dakika

27.1 Birim Testleri

Rust and Cargo come with a simple unit test framework:

- Unit tests are supported throughout your code.
- Integration tests are supported via the `tests/` directory.

Tests are marked with `#[test]`. Unit tests are often put in a nested `tests` module, using `#[cfg(test)]` to conditionally compile them only when building tests.

```
fn first_word(text: &str) -> &str {
    match text.find(' ') {
        Some(idx) => &text[..idx],
        None => &text,
    }
}

mod tests {
    use super::*;

    fn test_empty() {
        assert_eq!(first_word(""), "");
    }

    fn test_single_word() {
```

```

    assert_eq!(first_word("Merhaba"), "Merhaba");
}

fn test_multiple_words() {
    assert_eq!(first_word("Merhaba Dünya"), "Merhaba");
}
}

```

- This lets you unit test private helpers.
- The `#[cfg(test)]` attribute is only active when you run `cargo test`.

Run the tests in the playground in order to show their results.

27.2 Diğer Test Türleri

Entegrasyon Testleri

If you want to test your library as a client, use an integration test.

Create a `.rs` file under `tests/`:

```

// tests/my_library.rs
use my_library::init;

fn test_init() {
    assert!(init().is_ok());
}

```

These tests only have access to the public API of your crate.

Dokümantasyon Testleri

Rust has built-in support for documentation tests:

```

/// Shortens a string to the given length.
///
/// ```
/// # use playground::shorten_string;
/// assert_eq!(shorten_string("Hello World", 5), "Hello");
/// assert_eq!(shorten_string("Hello World", 20), "Hello World");
/// ```
pub fn shorten_string(s: &str, length: usize) -> &str {
    &s[..std::cmp::min(length, s.len())]
}

```

- Code blocks in `///` comments are automatically seen as Rust code.
- The code will be compiled and executed as part of `cargo test`.
- Adding `#` in the code will hide it from the docs, but will still compile/run it.
- Test the above code on the [Rust Playground](#).

27.3 Derleyici Tüyleri (Lint) ve Clippy Aracı

The Rust compiler produces fantastic error messages, as well as helpful built-in lints. **Clippy** provides even more lints, organized into groups that can be enabled per-project.

```
fn main() {
    let x = 3;
    while (x < 70000) {
        x *= 2;
    }
    println!("X probably fits in a u16, right? {}", x as u16);
}
```

Run the code sample and examine the error message. There are also lints visible here, but those will not be shown once the code compiles. Switch to the Playground site to show those lints.

After resolving the lints, run `clippy` on the playground site to show clippy warnings. Clippy has extensive documentation of its lints, and adds new lints (including default-deny lints) all the time.

Note that errors or warnings with help: ... can be fixed with `cargo fix` or via your editor.

27.4 Alıştırma: Luhn Algoritması

The **Luhn algorithm** is used to validate credit card numbers. The algorithm takes a string as input and does the following to validate the credit card number:

- Ignore all spaces. Reject numbers with fewer than two digits.
- Moving from **right to left**, double every second digit: for the number 1234, we double 3 and 1. For the number 98765, we double 6 and 8.
- After doubling a digit, sum the digits if the result is greater than 9. So doubling 7 becomes 14 which becomes $1 + 4 = 5$.
- Sum all the undoubled and doubled digits.
- The credit card number is valid if the sum ends with 0.

The provided code provides a buggy implementation of the luhn algorithm, along with two basic unit tests that confirm that most of the algorithm is implemented correctly.

Copy the code below to <https://play.rust-lang.org/> and write additional tests to uncover bugs in the provided implementation, fixing any bugs you find.

```
pub fn luhn(cc_number: &str) -> bool {
    let mut sum = 0;
    let mut double = false;

    for c in cc_number.chars().rev() {
        if let Some(digit) = c.to_digit(10) {
            if double {
                let double_digit = digit * 2;
                sum +=
                    if double_digit > 9 { double_digit - 9 } else { double_digit };
            }
        }
    }
}
```

```

        } else {
            sum += digit;
        }
        double = !double;
    } else {
        continue;
    }
}

sum % 10 == 0
}

mod test {
    use super::*;

    fn test_valid_cc_number() {
        assert!(luhn("4263 9826 4026 9299"));
        assert!(luhn("4539 3195 0343 6467"));
        assert!(luhn("7992 7398 713"));
    }

    fn test_invalid_cc_number() {
        assert!(!luhn("4223 9826 4026 9299"));
        assert!(!luhn("4539 3195 0343 6476"));
        assert!(!luhn("8273 1232 7352 0569"));
    }
}

```

27.4.1 Çözüm

```

// This is the buggy version that appears in the problem.
pub fn luhn(cc_number: &str) -> bool {
    let mut sum = 0;
    let mut double = false;

    for c in cc_number.chars().rev() {
        if let Some(digit) = c.to_digit(10) {
            if double {
                let double_digit = digit * 2;
                sum +=
                    if double_digit > 9 { double_digit - 9 } else { double_digit };
            } else {
                sum += digit;
            }
            double = !double;
        } else {
            continue;
        }
    }

    sum % 10 == 0
}

```

```

}

// This is the solution and passes all of the tests below.
pub fn luhn(cc_number: &str) -> bool {
    let mut sum = 0;
    let mut double = false;
    let mut digits = 0;

    for c in cc_number.chars().rev() {
        if let Some(digit) = c.to_digit(10) {
            digits += 1;
            if double {
                let double_digit = digit * 2;
                sum +=
                    if double_digit > 9 { double_digit - 9 } else { double_digit };
            } else {
                sum += digit;
            }
            double = !double;
        } else if c.is_whitespace() {
            // New: accept whitespace.
            continue;
        } else {
            // New: reject all other characters.
            return false;
        }
    }

    // New: check that we have at least two digits
    digits >= 2 && sum % 10 == 0
}

fn main() {
    let cc_number = "1234 5678 1234 5670";
    println!(
        "Is {cc_number} a valid credit card number? {}",
        if luhn(cc_number) { "yes" } else { "no" }
    );
}

mod test {
    use super::*;

    fn test_valid_cc_number() {
        assert!(luhn("4263 9826 4026 9299"));
        assert!(luhn("4539 3195 0343 6467"));
        assert!(luhn("7992 7398 713"));
    }

    fn test_invalid_cc_number() {
        assert!(!luhn("4223 9826 4026 9299"));
    }
}

```



```

    assert!(!luhn("4539 3195 0343 6476"));
    assert!(!luhn("8273 1232 7352 0569"));
}

fn test_non_digit_cc_number() {
    assert!(!luhn("foo"));
    assert!(!luhn("foo 0 0"));
}

fn test_empty_cc_number() {
    assert!(!luhn(""));
    assert!(!luhn(" "));
    assert!(!luhn("  "));
    assert!(!luhn("   "));
}

fn test_single_digit_cc_number() {
    assert!(!luhn("0"));
}

fn test_two_digit_cc_number() {
    assert!(luhn(" 0 0 "));
}
}

```

Kısım VIII

Gün 4: Öğleden Sonra

Bölüm 28

Tekrar Hoş Geldiniz

Bu oturum 10 dakikalık aralar dahil yaklaşık 2 saat 20 dakika sürmelidir. İçeriği:

Bölüm	Süre
Hata İşleme	1 saat 5 dakika
Emniyetsiz (Unsafe) Rust	1 saat 5 dakika

Bölüm 29

Hata İşleme

Bu bölüm yaklaşık 1 saat 5 dakika sürmelidir. İçeriği:

Slayt	Süre
Panic'ler	3 dakika
Result	5 dakika
Try Operatörü	5 dakika
Try Dönüşümleri	5 dakika
Error Özelliği (Trait)	5 dakika
thiserror	5 dakika
anyhow	5 dakika
Alıştırma: Result ile Yeniden Yazma	30 dakika

29.1 Panic'ler

Rust handles fatal errors with a "panic".

Rust will trigger a panic if a fatal error happens at runtime:

```
fn main() {  
    let v = vec![10, 20, 30];  
    println!("v[100]: {}", v[100]);  
}
```

- Panics are for unrecoverable and unexpected errors.
 - Panics are symptoms of bugs in the program.
 - Runtime failures like failed bounds checks can panic
 - Assertions (such as `assert!`) panic on failure
 - Purpose-specific panics can use the `panic!` macro.
- A panic will "unwind" the stack, dropping values just as if the functions had returned.
- Use non-panicking APIs (such as `Vec::get`) if crashing is not acceptable.

By default, a panic will cause the stack to unwind. The unwinding can be caught:

```
use std::panic;
```

```

fn main() {
    let result = panic::catch_unwind(|| "No problem here!");
    println!("{result:?}");

    let result = panic::catch_unwind(|| {
        panic!("oh no!");
    });
    println!("{result:?}");
}

```

- Catching is unusual; do not attempt to implement exceptions with `catch_unwind!`
- This can be useful in servers which should keep running even if a single request crashes.
- This does not work if `panic = 'abort'` is set in your `Cargo.toml`.

29.2 Result

Our primary mechanism for error handling in Rust is the `Result` enum, which we briefly saw when discussing standard library types.

```

use std::fs::File;
use std::io::Read;

fn main() {
    let file: Result<File, std::io::Error> = File::open("diary.txt");
    match file {
        Ok(mut file) => {
            let mut contents = String::new();
            if let Ok(bytes) = file.read_to_string(&mut contents) {
                println!("Dear diary: {contents} ({bytes} bytes)");
            } else {
                println!("Could not read file content");
            }
        }
        Err(err) => {
            println!("The diary could not be opened: {err}");
        }
    }
}

```

- `Result` has two variants: `Ok` which contains the success value, and `Err` which contains an error value of some kind.
- Whether or not a function can produce an error is encoded in the function's type signature by having the function return a `Result` value.
- Like with `Option`, there is no way to forget to handle an error: You cannot access either the success value or the error value without first pattern matching on the `Result` to check which variant you have. Methods like `unwrap` make it easier to write quick-and-dirty code that doesn't do robust error handling, but means that you can always see in your source code where proper error handling is being skipped.

Daha Fazlasını Keşfedin

It may be helpful to compare error handling in Rust to error handling conventions that students may be familiar with from other programming languages.

İstisnalar

- Many languages use exceptions, e.g. C++, Java, Python.
- In most languages with exceptions, whether or not a function can throw an exception is not visible as part of its type signature. This generally means that you can't tell when calling a function if it may throw an exception or not.
- Exceptions generally unwind the call stack, propagating upward until a try block is reached. An error originating deep in the call stack may impact an unrelated function further up.

Error Numbers

- Some languages have functions return an error number (or some other error value) separately from the successful return value of the function. Examples include C and Go.
- Depending on the language it may be possible to forget to check the error value, in which case you may be accessing an uninitialized or otherwise invalid success value.

29.3 Try Operatörü

Runtime errors like connection-refused or file-not-found are handled with the `Result` type, but matching this type on every call can be cumbersome. The try-operator `?` is used to return errors to the caller. It lets you turn the common

```
match some_expression {
    Ok(value) => value,
    Err(err) => return Err(err),
}
```

into the much simpler

```
some_expression?
```

We can use this to simplify our error handling code:

```
use std::io::Read;
use std::{fs, io};

fn read_username(path: &str) -> Result<String, io::Error> {
    let username_file_result = fs::File::open(path);
    let mut username_file = match username_file_result {
        Ok(file) => file,
        Err(err) => return Err(err),
    };

    let mut username = String::new();
```

```

    match username_file.read_to_string(&mut username) {
        Ok(_) => Ok(username),
        Err(err) => Err(err),
    }
}

fn main() {
    //fs::write("config.dat", "alice").unwrap();
    let username = read_username("config.dat");
    println!("username or error: {username:?}");
}

```

Simplify the `read_username` function to use `?`.

Anahtar noktalar:

- The `username` variable can be either `Ok(string)` or `Err(error)`.
- Use the `fs::write` call to test out the different scenarios: no file, empty file, file with username.
- Note that `main` can return a `Result<(), E>` as long as it implements `std::process::Termination`. In practice, this means that `E` implements `Debug`. The executable will print the `Err` variant and return a nonzero exit status on error.

29.4 Try Dönüşümleri

The effective expansion of `?` is a little more complicated than previously indicated:
expression?

works the same as

```

match expression {
    Ok(value) => value,
    Err(err) => return Err(From::from(err)),
}

```

The `From::from` call here means we attempt to convert the error type to the type returned by the function. This makes it easy to encapsulate errors into higher-level errors.

Örnek

```

use std::error::Error;
use std::io::Read;
use std::{fmt, fs, io};

enum ReadUsernameError {
    IoError(io::Error),
    EmptyUsername(String),
}

impl Error for ReadUsernameError {}

impl fmt::Display for ReadUsernameError {

```

```

fn fmt(&self, f: &mut fmt::Formatter) -> fmt::Result {
    match self {
        Self::IoError(e) => write!(f, "I/O error: {e}"),
        Self::EmptyUsername(path) => write!(f, "Found no username in {path}"),
    }
}

impl From<io::Error> for ReadUsernameError {
    fn from(err: io::Error) -> Self {
        Self::IoError(err)
    }
}

fn read_username(path: &str) -> Result<String, ReadUsernameError> {
    let mut username = String::with_capacity(100);
    fs::File::open(path)?.read_to_string(&mut username)?;
    if username.is_empty() {
        return Err(ReadUsernameError::EmptyUsername(String::from(path)));
    }
    Ok(username)
}

fn main() {
    //std::fs::write("config.dat", "").unwrap();
    let username = read_username("config.dat");
    println!("username or error: {username:?}");
}

```

The `?` operator must return a value compatible with the return type of the function. For `Result`, it means that the error types have to be compatible. A function that returns `Result<T, ErrorOuter>` can only use `?` on a value of type `Result<U, ErrorInner>` if `ErrorOuter` and `ErrorInner` are the same type or if `ErrorOuter` implements `From<ErrorInner>`.

A common alternative to a `From` implementation is `Result::map_err`, especially when the conversion only happens in one place.

There is no compatibility requirement for `Option`. A function returning `Option<T>` can use the `?` operator on `Option<U>` for arbitrary `T` and `U` types.

A function that returns `Result` cannot use `?` on `Option` and vice versa. However, `Option::ok_or` converts `Option` to `Result` whereas `Result::ok` turns `Result` into `Option`.

29.5 Dinamik Hata Türleri

Sometimes we want to allow any type of error to be returned without writing our own enum covering all the different possibilities. The `std::error::Error` trait makes it easy to create a trait object that can contain any error.

```

use std::error::Error;
use std::fs;
use std::io::Read;

fn read_count(path: &str) -> Result<i32, Box<dyn Error>> {
    let mut count_str = String::new();
    fs::File::open(path)?.read_to_string(&mut count_str)?;
    let count: i32 = count_str.parse()?;
    Ok(count)
}

fn main() {
    fs::write("count.dat", "1i3").unwrap();
    match read_count("count.dat") {
        Ok(count) => println!("Count: {count}"),
        Err(err) => println!("Error: {err}"),
    }
}

```

The `read_count` function can return `std::io::Error` (from file operations) or `std::num::ParseIntError` (from `String::parse`).

Boxing errors saves on code, but gives up the ability to cleanly handle different error cases differently in the program. As such it's generally not a good idea to use `Box<dyn Error>` in the public API of a library, but it can be a good option in a program where you just want to display the error message somewhere.

Make sure to implement the `std::error::Error` trait when defining a custom error type so it can be boxed.

29.6 thiserror

The `thiserror` crate provides macros to help avoid boilerplate when defining error types. It provides derive macros that assist in implementing `From<T>`, `Display`, and the `Error` trait.

```

use std::io::Read;
use std::{fs, io};
use thiserror::Error;

enum ReadUsernameError {
    IoError(#[from] io::Error),
    EmptyUsername(String),
}

fn read_username(path: &str) -> Result<String, ReadUsernameError> {
    let mut username = String::with_capacity(100);
    fs::File::open(path)?.read_to_string(&mut username)?;
    if username.is_empty() {
        return Err(ReadUsernameError::EmptyUsername(String::from(path)));
    }
    Ok(username)
}

```

```
fn main() {
    //fs::write("config.dat", "").unwrap();
    match read_username("config.dat") {
        Ok(username) => println!("Username: {username}"),
        Err(err) => println!("Error: {err:?}"),
    }
}
```

- The `Error` derive macro is provided by `thiserror`, and has lots of useful attributes to help define error types in a compact way.
- The message from `#[error]` is used to derive the `Display` trait.
- Note that the `(thiserror::)Error` derive macro, while it has the effect of implementing the `(std::error::)Error` trait, is not the same this; traits and macros do not share a namespace.

29.7 anyhow

The `anyhow` crate provides a rich error type with support for carrying additional contextual information, which can be used to provide a semantic trace of what the program was doing leading up to the error.

This can be combined with the convenience macros from `thiserror` to avoid writing out trait impls explicitly for custom error types.

```
use anyhow::{bail, Context, Result};
use std::fs;
use std::io::Read;
use thiserror::Error;

struct EmptyUsernameError(String);

fn read_username(path: &str) -> Result<String> {
    let mut username = String::with_capacity(100);
    fs::File::open(path)
        .with_context(|| format!("Failed to open {path}"))?
        .read_to_string(&mut username)
        .context("Failed to read")?;
    if username.is_empty() {
        bail!(EmptyUsernameError(path.to_string()));
    }
    Ok(username)
}

fn main() {
    //fs::write("config.dat", "").unwrap();
    match read_username("config.dat") {
        Ok(username) => println!("Username: {username}"),
        Err(err) => println!("Error: {err:?}"),
    }
}
```

- `anyhow::Error` is essentially a wrapper around `Box<dyn Error>`. As such it's again generally not a good choice for the public API of a library, but is widely used in applications.
- `anyhow::Result<V>` is a type alias for `Result<V, anyhow::Error>`.
- Functionality provided by `anyhow::Error` may be familiar to Go developers, as it provides similar behavior to the Go error type and `Result<T, anyhow::Error>` is much like a Go `(T, error)` (with the convention that only one element of the pair is meaningful).
- `anyhow::Context` is a trait implemented for the standard `Result` and `Option` types. use `anyhow::Context` is necessary to enable `.context()` and `.with_context()` on those types.

Daha Fazlasını Keşfedin

- `anyhow::Error` has support for downcasting, much like `std::any::Any`; the specific error type stored inside can be extracted for examination if desired with `Error::downcast`.

29.8 Alıştırma: Result ile Yeniden Yazma

The following implements a very simple parser for an expression language. However, it handles errors by panicking. Rewrite it to instead use idiomatic error handling and propagate errors to a return from `main`. Feel free to use `thiserror` and `anyhow`.

Hint: start by fixing error handling in the `parse` function. Once that is working correctly, update `Tokenizer` to implement `Iterator<Item=Result<Token, TokenizerError>>` and handle that in the parser.

```
use std::iter::Peekable;
use std::str::Chars;

/// An arithmetic operator.
enum Op {
    Add,
    Sub,
}

/// A token in the expression language.
enum Token {
    Number(String),
    Identifier(String),
    Operator(Op),
}

/// An expression in the expression language.
enum Expression {
    /// A reference to a variable.
    Var(String),
    /// A literal number.
    Number(u32),
}
```

```

    /// A binary operation.
    Operation(Box<Expression>, Op, Box<Expression>),
}

fn tokenize(input: &str) -> Tokenizer {
    return Tokenizer(input.chars().peekable());
}

struct Tokenizer<'a>(Peekable<Chars<'a>>);

impl<'a> Tokenizer<'a> {
    fn collect_number(&mut self, first_char: char) -> Token {
        let mut num = String::from(first_char);
        while let Some(&c @ '0'..'9') = self.0.peek() {
            num.push(c);
            self.0.next();
        }
        Token::Number(num)
    }

    fn collect_identifier(&mut self, first_char: char) -> Token {
        let mut ident = String::from(first_char);
        while let Some(&c @ ('a'..'z' | '_' | '0'..'9')) = self.0.peek() {
            ident.push(c);
            self.0.next();
        }
        Token::Identifier(ident)
    }
}

impl<'a> Iterator for Tokenizer<'a> {
    type Item = Token;

    fn next(&mut self) -> Option<Token> {
        let c = self.0.next()?;
        match c {
            '0'..'9' => Some(self.collect_number(c)),
            'a'..'z' => Some(self.collect_identifier(c)),
            '+' => Some(Token::Operator(Op::Add)),
            '-' => Some(Token::Operator(Op::Sub)),
            _ => panic!("Unexpected character {c}"),
        }
    }
}

fn parse(input: &str) -> Expression {
    let mut tokens = tokenize(input);

    fn parse_expr<'a>(tokens: &mut Tokenizer<'a>) -> Expression {
        let Some(tok) = tokens.next() else {
            panic!("Unexpected end of input");
        }
    }
}

```

```

};
let expr = match tok {
    Token::Number(num) => {
        let v = num.parse().expect("Invalid 32-bit integer");
        Expression::Number(v)
    }
    Token::Identifier(ident) => Expression::Var(ident),
    Token::Operator(_) => panic!("Unexpected token {tok:?}"),
};
// Look ahead to parse a binary operation if present.
match tokens.next() {
    None => expr,
    Some(Token::Operator(op)) => Expression::Operation(
        Box::new(expr),
        op,
        Box::new(parse_expr(tokens)),
    ),
    Some(tok) => panic!("Unexpected token {tok:?}"),
}
}

parse_expr(&mut tokens)
}

fn main() {
    let expr = parse("10+foo+20-30");
    println!("{expr:?}");
}

```

29.8.1 Çözüm

```

use thiserror::Error;
use std::iter::Peekable;
use std::str::Chars;

/// An arithmetic operator.
enum Op {
    Add,
    Sub,
}

/// A token in the expression language.
enum Token {
    Number(String),
    Identifier(String),
    Operator(Op),
}

/// An expression in the expression language.
enum Expression {
    /// A reference to a variable.

```

```

    Var(String),
    /// A literal number.
    Number(u32),
    /// A binary operation.
    Operation(Box<Expression>, Op, Box<Expression>),
}

fn tokenize(input: &str) -> Tokenizer {
    return Tokenizer(input.chars().peekable());
}

enum TokenizerError {
    UnexpectedCharacter(char),
}

struct Tokenizer<'a>(Peekable<Chars<'a>>);

impl<'a> Tokenizer<'a> {
    fn collect_number(&mut self, first_char: char) -> Token {
        let mut num = String::from(first_char);
        while let Some(&c @ '0'..'9') = self.0.peek() {
            num.push(c);
            self.0.next();
        }
        Token::Number(num)
    }

    fn collect_identifier(&mut self, first_char: char) -> Token {
        let mut ident = String::from(first_char);
        while let Some(&c @ ('a'..'z' | '_' | '0'..'9')) = self.0.peek() {
            ident.push(c);
            self.0.next();
        }
        Token::Identifier(ident)
    }
}

impl<'a> Iterator for Tokenizer<'a> {
    type Item = Result<Token, TokenizerError>;

    fn next(&mut self) -> Option<Result<Token, TokenizerError>> {
        let c = self.0.next()?;
        match c {
            '0'..'9' => Some(Ok(self.collect_number(c))),
            'a'..'z' | '_' => Some(Ok(self.collect_identifier(c))),
            '+' => Some(Ok(Token::Operator(Op::Add))),
            '-' => Some(Ok(Token::Operator(Op::Sub))),
            _ => Some(Err(TokenizerError::UnexpectedCharacter(c))),
        }
    }
}

```

```

enum ParserError {
    TokenizerError(#[from] TokenizerError),
    UnexpectedEOF,
    UnexpectedToken(Token),
    InvalidNumber(#[from] std::num::ParseIntError),
}

fn parse(input: &str) -> Result<Expression, ParserError> {
    let mut tokens = tokenize(input);

    fn parse_expr<'a>(
        tokens: &mut Tokenizer<'a>,
    ) -> Result<Expression, ParserError> {
        let tok = tokens.next().ok_or(ParserError::UnexpectedEOF)?;
        let expr = match tok {
            Token::Number(num) => {
                let v = num.parse()?;
                Expression::Number(v)
            }
            Token::Identifier(ident) => Expression::Var(ident),
            Token::Operator(_) => return Err(ParserError::UnexpectedToken(tok)),
        };
        // Look ahead to parse a binary operation if present.
        Ok(match tokens.next() {
            None => expr,
            Some(Ok(Token::Operator(op))) => Expression::Operation(
                Box::new(expr),
                op,
                Box::new(parse_expr(tokens)?),
            ),
            Some(Err(e)) => return Err(e.into()),
            Some(Ok(tok)) => return Err(ParserError::UnexpectedToken(tok)),
        })
    }

    parse_expr(&mut tokens)
}

fn main() -> anyhow::Result<()> {
    let expr = parse("10+foo+20-30")?;
    println!("{}", expr);
    Ok(())
}

```

Bölüm 30

Emniyetsiz (Unsafe) Rust

Bu bölüm yaklaşık 1 saat 5 dakika sürmelidir. İçeriği:

Slayt	Süre
Emniyetsiz	5 dakika
Ham Göstericilerinin İçeriği (Dereferencing)	10 dakika
Değişebilir Statik Değişkenler	5 dakika
Birlikler (Unions)	5 dakika
Emniyetsiz Fonksiyonlar	5 dakika
Emniyetsiz Özellikler (Traits)	5 dakika
Alıştırma: FFI Sarmalayıcı	30 dakika

30.1 Emniyetsiz (Unsafe) Rust

The Rust language has two parts:

- **Safe Rust:** memory safe, no undefined behavior possible.
- **Unsafe Rust:** can trigger undefined behavior if preconditions are violated.

We saw mostly safe Rust in this course, but it's important to know what Unsafe Rust is.

Unsafe code is usually small and isolated, and its correctness should be carefully documented. It is usually wrapped in a safe abstraction layer.

Unsafe Rust gives you access to five new capabilities:

- Dereference raw pointers.
- Access or modify mutable static variables.
- Access union fields.
- Call unsafe functions, including extern functions.
- Implement unsafe traits.

We will briefly cover unsafe capabilities next. For full details, please see [Chapter 19.1 in the Rust Book](#) and the [Rustonomicon](#).

Unsafe Rust does not mean the code is incorrect. It means that developers have turned off some compiler safety features and have to write correct code by themselves. It means the compiler no longer enforces Rust's memory-safety rules.

30.2 Ham Göstericilerinin İçeriği (Dereferencing)

Creating pointers is safe, but dereferencing them requires `unsafe`:

```
fn main() {
    let mut s = String::from("careful!");

    let r1 = &raw mut s;
    let r2 = r1 as *const String;

    // SAFETY: r1 and r2 were obtained from references and so are guaranteed to
    // be non-null and properly aligned, the objects underlying the references
    // from which they were obtained are live throughout the whole unsafe
    // block, and they are not accessed either through the references or
    // concurrently through any other pointers.
    unsafe {
        println!("r1 is: {}", *r1);
        *r1 = String::from("uhoh");
        println!("r2 is: {}", *r2);
    }

    // NOT SAFE. DO NOT DO THIS.
    /*
    let r3: &String = unsafe { &*r1 };
    drop(s);
    println!("r3 is: {}", *r3);
    */
}
```

It is good practice (and required by the Android Rust style guide) to write a comment for each `unsafe` block explaining how the code inside it satisfies the safety requirements of the unsafe operations it is doing.

In the case of pointer dereferences, this means that the pointers must be *valid*, i.e.:

- The pointer must be non-null.
- The pointer must be *dereferenceable* (within the bounds of a single allocated object).
- The object must not have been deallocated.
- There must not be concurrent accesses to the same location.
- If the pointer was obtained by casting a reference, the underlying object must be live and no reference may be used to access the memory.

In most cases the pointer must also be properly aligned.

The "NOT SAFE" section gives an example of a common kind of UB bug: `*r1` has the 'static lifetime, so `r3` has type `&'static String`, and thus outlives `s`. Creating a reference from a pointer requires *great care*.

30.3 Değişebilir Statik Değişkenler

It is safe to read an immutable static variable:

```
static HELLO_WORLD: &str = "Merhaba, dünya!";

fn main() {
    println!("HELLO_WORLD: {HELLO_WORLD}");
}
```

However, since data races can occur, it is unsafe to read and write mutable static variables:

```
static mut COUNTER: u32 = 0;

fn add_to_counter(inc: u32) {
    // SAFETY: There are no other threads which could be accessing `COUNTER`.
    unsafe {
        COUNTER += inc;
    }
}

fn main() {
    add_to_counter(42);

    // SAFETY: There are no other threads which could be accessing `COUNTER`.
    unsafe {
        println!("COUNTER: {COUNTER}");
    }
}
```

- The program here is safe because it is single-threaded. However, the Rust compiler is conservative and will assume the worst. Try removing the `unsafe` and see how the compiler explains that it is undefined behavior to mutate a static from multiple threads.
- Using a mutable static is generally a bad idea, but there are some cases where it might make sense in low-level `no_std` code, such as implementing a heap allocator or working with some C APIs.

30.4 Birlikler (Unions)

Unions are like enums, but you need to track the active field yourself:

```
union MyUnion {
    i: u8,
    b: bool,
}

fn main() {
    let u = MyUnion { i: 42 };
    println!("int: {}", unsafe { u.i });
    println!("bool: {}", unsafe { u.b }); // Undefined behavior!
}
```

Unions are very rarely needed in Rust as you can usually use an enum. They are occasionally needed for interacting with C library APIs.

If you just want to reinterpret bytes as a different type, you probably want `std::mem::transmute` or a safe wrapper such as the `zerocopy` crate.

30.5 Emniyetsiz Fonksiyonlar

Emniyetsiz (Unsafe) Fonksiyonları Çağırma

A function or method can be marked `unsafe` if it has extra preconditions you must uphold to avoid undefined behaviour:

```
extern "C" {
    fn abs(input: i32) -> i32;
}

fn main() {
    let emojis = "🌋🇪🇺";

    // SAFETY: The indices are in the correct order, within the bounds of the
    // string slice, and lie on UTF-8 sequence boundaries.
    unsafe {
        println!("emoji: {}", emojis.get_unchecked(0..4));
        println!("emoji: {}", emojis.get_unchecked(4..7));
        println!("emoji: {}", emojis.get_unchecked(7..11));
    }

    println!("char count: {}", count_chars(unsafe { emojis.get_unchecked(0..7) }));

    // SAFETY: `abs` doesn't deal with pointers and doesn't have any safety
    // requirements.
    unsafe {
        println!("Absolute value of -3 according to C: {}", abs(-3));
    }

    // Not upholding the UTF-8 encoding requirement breaks memory safety!
    // println!("emoji: {}", unsafe { emojis.get_unchecked(0..3) });
    // println!("char count: {}", count_chars(unsafe {
    //     emojis.get_unchecked(0..3) }));
}

fn count_chars(s: &str) -> usize {
    s.chars().count()
}
```

Emniyetsiz (Unsafe) Fonksiyonlar Yazma

You can mark your own functions as `unsafe` if they require particular conditions to avoid undefined behaviour.

```

/// Swaps the values pointed to by the given pointers.
///
/// # Safety
///
/// The pointers must be valid and properly aligned.
unsafe fn swap(a: *mut u8, b: *mut u8) {
    let temp = *a;
    *a = *b;
    *b = temp;
}

fn main() {
    let mut a = 42;
    let mut b = 66;

    // SAFETY: ...
    unsafe {
        swap(&mut a, &mut b);
    }

    println!("a = {}, b = {}", a, b);
}

```

Emniyetsiz (Unsafe) Fonksiyonları Çağırma

`get_unchecked`, like most `_unchecked` functions, is unsafe, because it can create UB if the range is incorrect. `abs` is unsafe for a different reason: it is an external function (FFI). Calling external functions is usually only a problem when those functions do things with pointers which might violate Rust's memory model, but in general any C function might have undefined behaviour under any arbitrary circumstances.

The "C" in this example is the ABI; **other ABIs are available too**.

Emniyetsiz (Unsafe) Fonksiyonlar Yazma

We wouldn't actually use pointers for a swap function - it can be done safely with references.

Note that unsafe code is allowed within an unsafe function without an `unsafe` block. We can prohibit this with `#[deny(unsafe_op_in_unsafe_fn)]`. Try adding it and see what happens. This will likely change in a future Rust edition.

30.6 Emniyetsiz Özelliklerin (Unsafe Traits) Gerçekleştirilmesi

Like with functions, you can mark a trait as `unsafe` if the implementation must guarantee particular conditions to avoid undefined behaviour.

For example, the `zerocopy` crate has an unsafe trait that looks **something like this**:

```

use std::{mem, slice};

/// ...

```

```

/// # Safety
/// The type must have a defined representation and no padding.
pub unsafe trait IntoBytes {
    fn as_bytes(&self) -> &[u8] {
        let len = mem::size_of_val(self);
        unsafe { slice::from_raw_parts((&raw const self).cast::<u8>(), len) }
    }
}

```

```

// SAFETY: `u32` has a defined representation and no padding.
unsafe impl IntoBytes for u32 {}

```

There should be a # Safety section on the Rustdoc for the trait explaining the requirements for the trait to be safely implemented.

The actual safety section for IntoBytes is rather longer and more complicated.

The built-in Send and Sync traits are unsafe.

30.7 Emniyetli FFI Sarıcı (Wrapper)

Rust has great support for calling functions through a *foreign function interface* (FFI). We will use this to build a safe wrapper for the libc functions you would use from C to read the names of files in a directory.

You will want to consult the manual pages:

- `opendir(3)`
- `readdir(3)`
- `closedir(3)`

You will also want to browse the `std::ffi` module. There you find a number of string types which you need for the exercise:

Türler	Encoding	Use
<code>str</code> and <code>String</code>	UTF-8	Text processing in Rust
<code>CStr</code> and <code>CString</code>	NUL-terminated	Communicating with C functions
<code>OsStr</code> and <code>OsString</code>	OS-specific	Communicating with the OS

You will convert between all these types:

- `&str` to `CString`: you need to allocate space for a trailing `\0` character,
- `CString` to `*const i8`: you need a pointer to call C functions,
- `*const i8` to `&CStr`: you need something which can find the trailing `\0` character,
- `&CStr` to `&[u8]`: a slice of bytes is the universal interface for "some unknown data",
- `&[u8]` to `&OsStr`: `&OsStr` is a step towards `OsString`, use `OsStrExt` to create it,

- `&OsStr` to `OsString`: you need to clone the data in `&OsStr` to be able to return it and call `readdir` again.

The **Nomicon** also has a very useful chapter about FFI.

Copy the code below to <https://play.rust-lang.org/> and fill in the missing functions and methods:

// **TODO**: uyarlamanız (implementation) bittiğinde bu yorum satırını silin.

```
mod ffi {
    use std::os::raw::{c_char, c_int};
    use std::os::raw::{c_long, c_uchar, c_ulong, c_ushort};

    // Opaque type. See https://doc.rust-lang.org/nomicon/ffi.html.
    pub struct DIR {
        _data: [u8; 0],
        _marker: core::marker::PhantomData<(*mut u8, core::marker::PhantomPinned)>,
    }

    // Layout according to the Linux man page for readdir(3), where ino_t and
    // off_t are resolved according to the definitions in
    // /usr/include/x86_64-linux-gnu/{sys/types.h, bits/typesizes.h}.
    pub struct dirent {
        pub d_ino: c_ulong,
        pub d_off: c_long,
        pub d_reclen: c_ushort,
        pub d_type: c_uchar,
        pub d_name: [c_char; 256],
    }

    // Layout according to the macOS man page for dir(5).
    pub struct dirent {
        pub d_fileno: u64,
        pub d_seekoff: u64,
        pub d_reclen: u16,
        pub d_namlen: u16,
        pub d_type: u8,
        pub d_name: [c_char; 1024],
    }

    unsafe extern "C" {
        pub unsafe fn opendir(s: *const c_char) -> *mut DIR;

        pub unsafe fn readdir(s: *mut DIR) -> *const dirent;

        // See https://github.com/rust-lang/libc/issues/414 and the section on
        // _DARWIN_FEATURE_64_BIT_INODE in the macOS man page for stat(2).
        //
        // "Platforms that existed before these updates were available" refers
        // to macOS (as opposed to iOS / wearOS / etc.) on Intel and PowerPC.
        pub unsafe fn readdir(s: *mut DIR) -> *const dirent;
    }
}
```

```

        pub unsafe fn closedir(s: *mut DIR) -> c_int;
    }
}

use std::ffi::{CStr, CString, OsStr, OsString};
use std::os::unix::ffi::OsStrExt;

struct DirectoryIterator {
    path: CString,
    dir: *mut ffi::DIR,
}

impl DirectoryIterator {
    fn new(path: &str) -> Result<DirectoryIterator, String> {
        // Call opendir and return a Ok value if that worked,
        // otherwise return Err with a message.
        unimplemented!()
    }
}

impl Iterator for DirectoryIterator {
    type Item = OsString;
    fn next(&mut self) -> Option<OsString> {
        // Keep calling readdir until we get a NULL pointer back.
        unimplemented!()
    }
}

impl Drop for DirectoryIterator {
    fn drop(&mut self) {
        // Call closedir as needed.
        unimplemented!()
    }
}

fn main() -> Result<(), String> {
    let iter = DirectoryIterator::new(".")?;
    println!("files: {:#?}", iter.collect::<Vec<_>>());
    Ok(())
}

```

30.7.1 Çözüm

```

mod ffi {
    use std::os::raw::{c_char, c_int};
    use std::os::raw::{c_long, c_uchar, c_ulong, c_ushort};

    // Opaque type. See https://doc.rust-lang.org/nomicon/ffi.html.
    pub struct DIR {
        _data: [u8; 0],
        _marker: core::marker::PhantomData<(*mut u8, core::marker::PhantomPinned)>,
    }
}

```

```

}

// Layout according to the Linux man page for readdir(3), where ino_t and
// off_t are resolved according to the definitions in
// /usr/include/x86_64-linux-gnu/{sys/types.h, bits/typesizes.h}.
pub struct dirent {
    pub d_ino: c_ulong,
    pub d_off: c_long,
    pub d_reclen: c_ushort,
    pub d_type: c_uchar,
    pub d_name: [c_char; 256],
}

// Layout according to the macOS man page for dir(5).
pub struct dirent {
    pub d_fileno: u64,
    pub d_seekoff: u64,
    pub d_reclen: u16,
    pub d_namlen: u16,
    pub d_type: u8,
    pub d_name: [c_char; 1024],
}

unsafe extern "C" {
    pub unsafe fn opendir(s: *const c_char) -> *mut DIR;

    pub unsafe fn readdir(s: *mut DIR) -> *const dirent;

    // See https://github.com/rust-lang/libc/issues/414 and the section on
    // _DARWIN_FEATURE_64_BIT_INODE in the macOS man page for stat(2).
    //
    // "Platforms that existed before these updates were available" refers
    // to macOS (as opposed to iOS / wearOS / etc.) on Intel and PowerPC.
    pub unsafe fn readdir(s: *mut DIR) -> *const dirent;

    pub unsafe fn closedir(s: *mut DIR) -> c_int;
}
}

use std::ffi::{CStr, CString, OsStr, OsString};
use std::os::unix::ffi::OsStrExt;

struct DirectoryIterator {
    path: CString,
    dir: *mut ffi::DIR,
}

impl DirectoryIterator {
    fn new(path: &str) -> Result<DirectoryIterator, String> {
        // Call opendir and return a Ok value if that worked,
        // otherwise return Err with a message.

```



```

    let path =
        CString::new(path).map_err(|err| format!("Invalid path: {err}"))?;
    // SAFETY: path.as_ptr() cannot be NULL.
    let dir = unsafe { ffi::opendir(path.as_ptr()) };
    if dir.is_null() {
        Err(format!("Could not open {path:?}"))
    } else {
        Ok(DirectoryIterator { path, dir })
    }
}

impl Iterator for DirectoryIterator {
    type Item = OsString;
    fn next(&mut self) -> Option<OsString> {
        // Keep calling readdir until we get a NULL pointer back.
        // SAFETY: self.dir is never NULL.
        let dirent = unsafe { ffi::readdir(self.dir) };
        if dirent.is_null() {
            // We have reached the end of the directory.
            return None;
        }
        // SAFETY: dirent is not NULL and dirent.d_name is NUL
        // terminated.
        let d_name = unsafe { CString::from_ptr((*dirent).d_name.as_ptr()) };
        let os_str = OsStr::from_bytes(d_name.to_bytes());
        Some(os_str.to_owned())
    }
}

impl Drop for DirectoryIterator {
    fn drop(&mut self) {
        // Call closedir as needed.
        // SAFETY: self.dir is never NULL.
        if unsafe { ffi::closedir(self.dir) } != 0 {
            panic!("Could not close {:?}", self.path);
        }
    }
}

fn main() -> Result<(), String> {
    let iter = DirectoryIterator::new(".")?;
    println!("files: {:#?}", iter.collect::<Vec<_>>());
    Ok(())
}

mod tests {
    use super::*;
    use std::error::Error;

    fn test_nonexisting_directory() {

```

```

    let iter = DirectoryIterator::new("no-such-directory");
    assert!(iter.is_err());
}

fn test_empty_directory() -> Result<(), Box<dyn Error>> {
    let tmp = tempfile::TempDir::new()?;
    let iter = DirectoryIterator::new(
        tmp.path().to_str().ok_or("Non UTF-8 character in path")?,
    );
    let mut entries = iter.collect::<Vec<_>>();
    entries.sort();
    assert_eq!(entries, &[".", ".."]);
    Ok(())
}

fn test_nonempty_directory() -> Result<(), Box<dyn Error>> {
    let tmp = tempfile::TempDir::new()?;
    std::fs::write(tmp.path().join("foo.txt"), "The Foo Diaries\n")?;
    std::fs::write(tmp.path().join("bar.png"), "<PNG>\n")?;
    std::fs::write(tmp.path().join("crab.rs"), "//! Crab\n")?;
    let iter = DirectoryIterator::new(
        tmp.path().to_str().ok_or("Non UTF-8 character in path")?,
    );
    let mut entries = iter.collect::<Vec<_>>();
    entries.sort();
    assert_eq!(entries, &[".", "..", "bar.png", "crab.rs", "foo.txt"]);
    Ok(())
}
}

```

Kısım IX

Android

Bölüm 31

Welcome to Rust in Android

Rust is supported for system software on Android. This means that you can write new services, libraries, drivers or even firmware in Rust (or improve existing code as needed).

The speaker may mention any of the following given the increased use of Rust in Android:

- Service example: [DNS over HTTP](#).
- Libraries: [Rutabaga Virtual Graphics Interface](#).
- Kernel Drivers: [Binder](#).
- Firmware: [pKVM firmware](#).

Bölüm 32

Kurulum (Setup)

We will be using a Cuttlefish Android Virtual Device to test our code. Make sure you have access to one or create a new one with:

```
source build/envsetup.sh
lunch aosp_cf_x86_64_phone-trunk_staging-userdebug
acloud create
```

Please see the [Android Developer Codelab](#) for details.

The code on the following pages can be found in the [src/android/ directory](#) of the course material. Please `git clone` the repository to follow along.

Anahtar noktalar:

- Cuttlefish is a reference Android device designed to work on generic Linux desktops. MacOS support is also planned.
- The Cuttlefish system image maintains high fidelity to real devices, and is the ideal emulator to run many Rust use cases.

Bölüm 33

İnşa (Build) Kuralları

The Android build system (Soong) supports Rust via a number of modules:

Module Type	Description
<code>rust_binary</code>	Produces a Rust binary.
<code>rust_library</code>	Produces a Rust library, and provides both <code>rlib</code> and <code>dllib</code> variants.
<code>rust_ffi</code>	Produces a Rust C library usable by <code>cc</code> modules, and provides both static and shared variants.
<code>rust_proc_macro</code>	Produces a <code>proc-macro</code> Rust library. These are analogous to compiler plugins.
<code>rust_test</code>	Produces a Rust test binary that uses the standard Rust test harness.
<code>rust_fuzz</code>	Produces a Rust fuzz binary leveraging <code>libfuzzer</code> .
<code>rust_protobuf</code>	Generates source and produces a Rust library that provides an interface for a particular <code>protobuf</code> .
<code>rust_bindgen</code>	Generates source and produces a Rust library containing Rust bindings to C libraries.

We will look at `rust_binary` and `rust_library` next.

Additional items speaker may mention:

- Cargo is not optimized for multi-language repos, and also downloads packages from the internet.
- For compliance and performance, Android must have crates in-tree. It must also interop with C/C++/Java code. Soong fills that gap.
- Soong has many similarities to [Bazel](#), which is the open-source variant of Blaze (used in `google3`).
- Fun fact: Data from Star Trek is a Soong-type Android.

33.1 Rust Binaries

Let us start with a simple application. At the root of an AOSP checkout, create the following files:

hello_rust/Android.bp:

```
rust_binary {
    name: "hello_rust",
    crate_name: "hello_rust",
    srcs: ["src/main.rs"],
}
```

hello_rust/src/main.rs:

```
/// Rust demo.

/// Prints a greeting to standard output.
fn main() {
    println!("Rust dilinden merhaba!");
}
```

You can now build, push, and run the binary:

```
m hello_rust
adb push "$ANDROID_PRODUCT_OUT/system/bin/hello_rust" /data/local/tmp
adb shell /data/local/tmp/hello_rust
```

Hello from Rust!

33.2 Rust Libraries

You use `rust_library` to create a new Rust library for Android.

Here we declare a dependency on two libraries:

- `libgreeting`, which we define below,
- `libtextwrap`, which is a crate already vendored in `external/rust/crates/`.

hello_rust/Android.bp:

```
rust_binary {
    name: "hello_rust_with_dep",
    crate_name: "hello_rust_with_dep",
    srcs: ["src/main.rs"],
    rustlibs: [
        "libgreetings",
        "libtextwrap",
    ],
    prefer_rlib: true, // Need this to avoid dynamic link error.
}
```

```
rust_library {
    name: "libgreetings",
    crate_name: "greetings",
```

```

    srcs: ["src/lib.rs"],
}
hello_rust/src/main.rs:
//! Rust demo.

use greetings::greeting;
use textwrap::fill;

/// Prints a greeting to standard output.
fn main() {
    println!("{}", fill(&greeting("Bob"), 24));
}
hello_rust/src/lib.rs:
//! Greeting library.

/// Greet `name`.
pub fn greeting(name: &str) -> String {
    format!("Hello {name}, it is very nice to meet you!")
}

```

You build, push, and run the binary like before:

```

m hello_rust_with_dep
adb push "$ANDROID_PRODUCT_OUT/system/bin/hello_rust_with_dep" /data/local/tmp
adb shell /data/local/tmp/hello_rust_with_dep
Hello Bob, it is very
nice to meet you!

```

Bölüm 34

AIDL

The **Android Interface Definition Language (AIDL)** is supported in Rust:

- Rust code can call existing AIDL servers,
- You can create new AIDL servers in Rust.
- AIDL is what enables Android apps to interact with each other.
- Since Rust is supported as a first-class citizen in this ecosystem, Rust services can be called by any other process on the phone.

34.1 Doğum Günü Servisi Eğitimi

To illustrate how to use Rust with Binder, we're going to walk through the process of creating a Binder interface. We're then going to both implement the described service and write client code that talks to that service.

34.1.1 AIDL Interfaces

You declare the API of your service using an AIDL interface:

birthday_service/aidl/com/example/birthdayservice/IBirthdayService.aidl:

```
package com.example.birthdayservice;  
  
/** Birthday service interface. */  
interface IBirthdayService {  
    /** Generate a Happy Birthday message. */  
    String wishHappyBirthday(String name, int years);  
}
```

birthday_service/aidl/Android.bp:

```
aidl_interface {  
    name: "com.example.birthdayservice",  
    srcs: ["com/example/birthdayservice/*.aidl"],  
    unstable: true,  
    backend: {
```

```

        rust: { // Rust is not enabled by default
            enabled: true,
        },
    },
}

```

- Note that the directory structure under the `aidl/` directory needs to match the package name used in the AIDL file, i.e. the package is `com.example.birthdayservice` and the file is at `aidl/com/example/IBirthdayService.aidl`.

34.1.2 Generated Service API

Binder generates a trait for each interface definition.

birthday_service/aidl/com/example/birthdayservice/IBirthdayService.aidl:

```

/** Birthday service interface. */
interface IBirthdayService {
    /** Generate a Happy Birthday message. */
    String wishHappyBirthday(String name, int years);
}

```

out/soong/intermediates/.../birthdayservice/IBirthdayService.rs:

```

trait IBirthdayService {
    fn wishHappyBirthday(&self, name: &str, years: i32) -> binder::Result<String>;
}

```

Your service will need to implement this trait, and your client will use this trait to talk to the service.

- Point out how the generated function signature, specifically the argument and return types, correspond the interface definition.
 - `String` for an argument results in a different Rust type than `String` as a return type.

34.1.3 Service Implementation

We can now implement the AIDL service:

birthday_service/src/lib.rs:

```

//! Implementation of the `IBirthdayService` AIDL interface.
use com_example_birthdayservice::aidl::com::example::birthdayservice::IBirthdayService;
use com_example_birthdayservice::binder;

/// The `IBirthdayService` implementation.
pub struct BirthdayService;

impl binder::Interface for BirthdayService {}

impl IBirthdayService for BirthdayService {
    fn wishHappyBirthday(&self, name: &str, years: i32) -> binder::Result<String> {
        Ok(format!("Happy Birthday {name}, congratulations with the {years} years!"))
    }
}

```

```

    }
}
birthday_service/Android.bp:
rust_library {
    name: "libbirthdayservice",
    srcs: ["src/lib.rs"],
    crate_name: "birthdayservice",
    rustlibs: [
        "com.example.birthdayservice-rust",
        "libbinder_rs",
    ],
}

```

- Point out the path to the generated `IBirthdayService` trait, and explain why each of the segments is necessary.
- TODO: What does the `binder::Interface` trait do? Are there methods to override? Where source?

34.1.4 AIDL Server

Finally, we can create a server which exposes the service:

```

birthday_service/src/server.rs:
/// Birthday service.
use birthdayservice::BirthdayService;
use com_example_birthdayservice::aidl::com::example::birthdayservice::IBirthdayService;
use com_example_birthdayservice::binder;

const SERVICE_IDENTIFIER: &str = "birthdayservice";

/// Entry point for birthday service.
fn main() {
    let birthday_service = BirthdayService;
    let birthday_service_binder = BnBirthdayService::new_binder(
        birthday_service,
        binder::BinderFeatures::default(),
    );
    binder::add_service(SERVICE_IDENTIFIER, birthday_service_binder.as_binder())
        .expect("Failed to register service");
    binder::ProcessState::join_thread_pool();
}

```

```

birthday_service/Android.bp:
rust_binary {
    name: "birthday_server",
    crate_name: "birthday_server",
    srcs: ["src/server.rs"],
    rustlibs: [
        "com.example.birthdayservice-rust",
        "libbinder_rs",
    ],
}

```

```

        "libbirthdayservice",
    ],
    prefer_rlib: true, // To avoid dynamic link error.
}

```

The process for taking a user-defined service implementation (in this case the `BirthdayService` type, which implements the `IBirthdayService`) and starting it as a Binder service has multiple steps, and may appear more complicated than students are used to if they've used Binder from C++ or another language. Explain to students why each step is necessary.

1. Create an instance of your service type (`BirthdayService`).
2. Wrap the service object in corresponding `Bn*` type (`BnBirthdayService` in this case). This type is generated by Binder and provides the common Binder functionality that would be provided by the `BnBinder` base class in C++. We don't have inheritance in Rust, so instead we use composition, putting our `BirthdayService` within the generated `BnBinderService`.
3. Call `add_service`, giving it a service identifier and your service object (the `BnBirthdayService` object in the example).
4. Call `join_thread_pool` to add the current thread to Binder's thread pool and start listening for connections.

34.1.5 Dağıtmak (Deploy)

We can now build, push, and start the service:

```

m birthday_server
adb push "$ANDROID_PRODUCT_OUT/system/bin/birthday_server" /data/local/tmp
adb root
adb shell /data/local/tmp/birthday_server

```

In another terminal, check that the service runs:

```
adb shell service check birthdayservice
```

```
Service birthdayservice: found
```

You can also call the service with `service call`:

```
adb shell service call birthdayservice 1 s16 Bob i32 24
```

```

Result: Parcel(
  0x00000000: 00000000 00000036 00610048 00700070 '...6...H.a.p.p.'
  0x00000010: 00200079 00690042 00740072 00640068 'y. .B.i.r.t.h.d.'
  0x00000020: 00790061 00420020 0062006f 0020002c 'a.y. .B.o.b.,. .'
  0x00000030: 006f0063 0067006e 00610072 00750074 'c.o.n.g.r.a.t.u.'
  0x00000040: 0061006c 00690074 006e006f 00200073 'l.a.t.i.o.n.s. .'
  0x00000050: 00690077 00680074 00740020 00650068 'w.i.t.h. .t.h.e.'
  0x00000060: 00320020 00200034 00650079 00720061 ' .2.4. .y.e.a.r.'
  0x00000070: 00210073 00000000 's.!..... ')

```

34.1.6 AIDL Client

Finally, we can create a Rust client for our new service.

birthday_service/src/client.rs:

```

use com_example_birthdayservice::aidl::com::example::birthdayservice::IBirthdayService;
use com_example_birthdayservice::binder;

const SERVICE_IDENTIFIER: &str = "birthdayservice";

// Call the birthday service.
fn main() -> Result<(), Box<dyn Error>> {
    let name = std::env::args().nth(1).unwrap_or_else(|| String::from("Bob"));
    let years = std::env::args()
        .nth(2)
        .and_then(|arg| arg.parse::<i32>().ok())
        .unwrap_or(42);

    binder::ProcessState::start_thread_pool();
    let service = binder::get_interface::<dyn IBirthdayService>(SERVICE_IDENTIFIER)
        .map_err(|_| "Failed to connect to BirthdayService"?);

    // Call the service.
    let msg = service.wishHappyBirthday(&name, years)?;
    println!("{}", msg);
}

birthday_service/Android.bp:
rust_binary {
    name: "birthday_client",
    crate_name: "birthday_client",
    srcs: ["src/client.rs"],
    rustlibs: [
        "com.example.birthdayservice-rust",
        "libbinder_rs",
    ],
    prefer_rlib: true, // To avoid dynamic link error.
}

```

Notice that the client does not depend on libbirthdayservice.

Build, push, and run the client on your device:

```

m birthday_client
adb push "$ANDROID_PRODUCT_OUT/system/bin/birthday_client" /data/local/tmp
adb shell /data/local/tmp/birthday_client Charlie 60

```

Happy Birthday Charlie, congratulations with the 60 years!

- `Strong<dyn IBirthdayService>` is the trait object representing the service that the client has connected to.
 - `Strong` is a custom smart pointer type for Binder. It handles both an in-process ref count for the service trait object, and the global Binder ref count that tracks how many processes have a reference to the object.
 - Note that the trait object that the client uses to talk to the service uses the exact same trait that the server implements. For a given Binder interface, there is a single Rust trait generated that both client and server use.

- Use the same service identifier used when registering the service. This should ideally be defined in a common crate that both the client and server can depend on.

34.1.7 API'yi Değiştirme

Let us extend the API with more functionality: we want to let clients specify a list of lines for the birthday card:

```
package com.example.birthdayservice;

/** Birthday service interface. */
interface IBirthdayService {
    /** Generate a Happy Birthday message. */
    String wishHappyBirthday(String name, int years, in String[] text);
}
```

This results in an updated trait definition for IBirthdayService:

```
trait IBirthdayService {
    fn wishHappyBirthday(
        &self,
        name: &str,
        years: i32,
        text: &[String],
    ) -> binder::Result<String>;
}
```

- Note how the `String[]` in the AIDL definition is translated as a `&[String]` in Rust, i.e. that idiomatic Rust types are used in the generated bindings wherever possible:
 - in array arguments are translated to slices.
 - out and inout args are translated to `&mut Vec<T>`.
 - Return values are translated to returning a `Vec<T>`.

34.1.8 Updating Client and Service

Update the client and server code to account for the new API.

birthday_service/src/lib.rs:

```
impl IBirthdayService for BirthdayService {
    fn wishHappyBirthday(
        &self,
        name: &str,
        years: i32,
        text: &[String],
    ) -> binder::Result<String> {
        let mut msg = format!(
            "Happy Birthday {name}, congratulations with the {years} years!",
        );

        for line in text {
            msg.push('\n');
            msg.push_str(line);
        }
    }
}
```

```

    }
    Ok(msg)
}
}

```

birthday_service/src/client.rs:

```

let msg = service.wishHappyBirthday(
    &name,
    years,
    &[
        String::from("Habby birfday to yuuuuu"),
        String::from("And also: many more"),
    ],
)?;

```

- TODO: Move code snippets into project files where they'll actually be built?

34.2 Working With AIDL Types

AIDL types translate into the appropriate idiomatic Rust type:

- Primitive types map (mostly) to idiomatic Rust types.
- Collection types like slices, Vecs and string types are supported.
- References to AIDL objects and file handles can be sent between clients and services.
- File handles and parcelables are fully supported.

34.2.1 İlkel (Primitive) Türler

Primitive types map (mostly) idiomatically:

AIDL Türü	Rust Türü	Note
boolean	bool	
byte	i8	Note that bytes are signed.
char	u16	Note the usage of u16, NOT u32.
int	i32	
long	i64	
float	f32	
double	f64	
String	String	

34.2.2 Dizi Türleri

The array types (`T[]`, `byte[]`, and `List<T>`) get translated to the appropriate Rust array type depending on how they are used in the function signature:

Position	Rust Türü
in argument	&[T]

Position	Rust Türü
out/inout argument	&mut Vec<T>
Return	Vec<T>

- In Android 13 or higher, fixed-size arrays are supported, i.e. `T[N]` becomes `[T; N]`. Fixed-size arrays can have multiple dimensions (e.g. `int [3] [4]`). In the Java backend, fixed-size arrays are represented as array types.
- Arrays in parcelable fields always get translated to `Vec<T>`.

34.2.3 Nesnelerin Gönderilmesi

AIDL objects can be sent either as a concrete AIDL type or as the type-erased `IBinder` interface:

birthday_service/aidl/com/example/birthdayservice/IBirthdayInfoProvider.aidl:

```
package com.example.birthdayservice;
```

```
interface IBirthdayInfoProvider {
    String name();
    int years();
}
```

birthday_service/aidl/com/example/birthdayservice/IBirthdayService.aidl:

```
import com.example.birthdayservice.IBirthdayInfoProvider;
```

```
interface IBirthdayService {
    /** The same thing, but using a binder object. */
    String wishWithProvider(IBirthdayInfoProvider provider);

    /** The same thing, but using `IBinder`. */
    String wishWithErasedProvider(IBinder provider);
}
```

birthday_service/src/client.rs:

```
/// Rust struct implementing the `IBirthdayInfoProvider` interface.
```

```
struct InfoProvider {
    name: String,
    age: u8,
}
```

```
impl binder::Interface for InfoProvider {}
```

```
impl IBirthdayInfoProvider for InfoProvider {
    fn name(&self) -> binder::Result<String> {
        Ok(self.name.clone())
    }
}
```

```
fn years(&self) -> binder::Result<i32> {
    Ok(self.age as i32)
}
```



```

    }
}

fn main() {
    binder::ProcessState::start_thread_pool();
    let service = connect().expect("Failed to connect to BirthdayService");

    // Create a binder object for the `IBirthdayInfoProvider` interface.
    let provider = BnBirthdayInfoProvider::new_binder(
        InfoProvider { name: name.clone(), age: years as u8 },
        BinderFeatures::default(),
    );

    // Send the binder object to the service.
    service.wishWithProvider(&provider)?;

    // Perform the same operation but passing the provider as an `SpIBinder`.
    service.wishWithErasedProvider(&provider.as_binder())?;
}

```

- Note the usage of BnBirthdayInfoProvider. This serves the same purpose as BnBirthdayService that we saw previously.

34.2.4 Parsellenebilir Gönderme

Binder for Rust supports sending parcelables directly:

birthday_service/aidl/com/example/birthdayservice/BirthdayInfo.aidl:

```
package com.example.birthdayservice;
```

```
parcelable BirthdayInfo {
    String name;
    int years;
}
```

birthday_service/aidl/com/example/birthdayservice/IBirthdayService.aidl:

```
import com.example.birthdayservice.BirthdayInfo;
```

```
interface IBirthdayService {
    /** The same thing, but with a parcelable. */
    String wishWithInfo(in BirthdayInfo info);
}
```

birthday_service/src/client.rs:

```
fn main() {
    binder::ProcessState::start_thread_pool();
    let service = connect().expect("Failed to connect to BirthdayService");

    let info = BirthdayInfo { name: "Alice".into(), years: 123 };
    service.wishWithInfo(&info)?;
}

```

34.2.5 Dosyaların Gönderilmesi

Files can be sent between Binder clients/servers using the `ParcelFileDescriptor` type:

birthday_service/aidl/com/example/birthdayservice/IBirthdayService.aidl:

```
interface IBirthdayService {  
    /** The same thing, but loads info from a file. */  
    String wishFromFile(in ParcelFileDescriptor infoFile);  
}
```

birthday_service/src/client.rs:

```
fn main() {  
    binder::ProcessState::start_thread_pool();  
    let service = connect().expect("Failed to connect to BirthdayService");  
  
    // Open a file and put the birthday info in it.  
    let mut file = File::create("/data/local/tmp/birthday.info").unwrap();  
    writeln!(file, "{name}")?;  
    writeln!(file, "{years}")?;  
  
    // Create a `ParcelFileDescriptor` from the file and send it.  
    let file = ParcelFileDescriptor::new(file);  
    service.wishFromFile(&file)?;  
}
```

birthday_service/src/lib.rs:

```
impl IBirthdayService for BirthdayService {  
    fn wishFromFile(  
        &self,  
        info_file: &ParcelFileDescriptor,  
    ) -> binder::Result<String> {  
        // Convert the file descriptor to a `File`. `ParcelFileDescriptor` wraps  
        // an `OwnedFd`, which can be cloned and then used to create a `File`  
        // object.  
        let mut info_file = info_file  
            .as_ref()  
            .try_clone()  
            .map(File::from)  
            .expect("Invalid file handle");  
  
        let mut contents = String::new();  
        info_file.read_to_string(&mut contents).unwrap();  
  
        let mut lines = contents.lines();  
        let name = lines.next().unwrap();  
        let years: i32 = lines.next().unwrap().parse().unwrap();  
  
        Ok(format!("Happy Birthday {name}, congratulations with the {years} years!"))  
    }  
}
```

- `ParcelFileDescriptor` wraps an `OwnedFd`, and so can be created from a `File` (or any

other type that wraps an `OwnedFd`), and can be used to create a new `File` handle on the other side.

- Other types of file descriptors can be wrapped and sent, e.g. TCP, UDP, and UNIX sockets.

Bölüm 35

Android'de Test Etme

Building on [Testing](#), we will now look at how unit tests work in AOSP. Use the `rust_test` module for your unit tests:

testing/Android.bp:

```
rust_library {
    name: "libleftpad",
    crate_name: "leftpad",
    srcs: ["src/lib.rs"],
}

rust_test {
    name: "libleftpad_test",
    crate_name: "leftpad_test",
    srcs: ["src/lib.rs"],
    host_supported: true,
    test_suites: ["general-tests"],
}
```

testing/src/lib.rs:

```
/// Left-padding library.

/// Left-pad `s` to `width`.
pub fn leftpad(s: &str, width: usize) -> String {
    format!("{s:>width$}")
}

mod tests {
    use super::*;

    fn short_string() {
        assert_eq!(leftpad("foo", 5), "  foo");
    }

    fn long_string() {
        assert_eq!(leftpad("foobar", 6), "foobar");
    }
}
```

```
}  
}
```

You can now run the test with

```
atext --host libleftpad_test
```

The output looks like this:

```
INFO: Elapsed time: 2.666s, Critical Path: 2.40s  
INFO: 3 processes: 2 internal, 1 linux-sandbox.  
INFO: Build completed successfully, 3 total actions  
//comprehensive-rust-android/testing:libleftpad_test_host          PASSED in 2.3s  
  PASSED libleftpad_test.tests::long_string (0.0s)  
  PASSED libleftpad_test.tests::short_string (0.0s)  
Test cases: finished with 2 passing and 0 failing out of 2 test cases
```

Notice how you only mention the root of the library crate. Tests are found recursively in nested modules.

35.1 GoogleTest

The `GoogleTest` crate allows for flexible test assertions using *matchers*:

```
use googletest::prelude::*;
```

```
fn test_elements_are() {  
    let value = vec!["foo", "bar", "baz"];  
    expect_that!(value, elements_are!(eq(&"foo"), lt(&"xyz"), starts_with("b")));  
}
```

If we change the last element to "!", the test fails with a structured error message pin-pointing the error:

```
---- test_elements_are stdout ----  
Value of: value  
Expected: has elements:  
  0. is equal to "foo"  
  1. is less than "xyz"  
  2. starts with prefix "!"  
Actual: ["foo", "bar", "baz"],  
  where element #2 is "baz", which does not start with "!"  
  at src/testing/googletest.rs:6:5  
Error: See failure output above
```

- `GoogleTest` is not part of the Rust Playground, so you need to run this example in a local environment. Use `cargo add googletest` to quickly add it to an existing Cargo project.
- The use `googletest::prelude::*`; line imports a number of **commonly used macros and types**.
- This just scratches the surface, there are many builtin matchers. Consider going through the first chapter of **"Advanced testing for Rust applications"**, a self-guided Rust course: it

provides a guided introduction to the library, with exercises to help you get comfortable with `googletest` macros, its matchers and its overall philosophy.

- A particularly nice feature is that mismatches in multi-line strings are shown as a diff:

```
fn test_multiline_string_diff() {
    let haiku = "Memory safety found,\n\
                Rust's strong typing guides the way,\n\
                Secure code you'll write.";
    assert_that!(
        haiku,
        eq("Memory safety found,\n\
            Rust's silly humor guides the way,\n\
            Secure code you'll write.")
    );
}
```

shows a color-coded diff (colors not shown here):

```
Value of: haiku
Expected: is equal to "Memory safety found,\nRust's silly humor guides the way,\nSecure
Actual: "Memory safety found,\nRust's strong typing guides the way,\nSecure code you'll
which isn't equal to "Memory safety found,\nRust's silly humor guides the way,\nSecure
Difference(-actual / +expected):
Memory safety found,
-Rust's strong typing guides the way,
+Rust's silly humor guides the way,
Secure code you'll write.
at src/testing/googletest.rs:17:5
```

- The crate is a Rust port of [GoogleTest for C++](#).

35.2 Taklit Etme (Mocking)

For mocking, `Mockall` is a widely used library. You need to refactor your code to use traits, which you can then quickly mock:

```
use std::time::Duration;

pub trait Pet {
    fn is_hungry(&self, since_last_meal: Duration) -> bool;
}

fn test_robot_dog() {
    let mut mock_dog = MockPet::new();
    mock_dog.expect_is_hungry().return_const(true);
    assert_eq!(mock_dog.is_hungry(Duration::from_secs(10)), true);
}
```

- `Mockall` is the recommended mocking library in Android (AOSP). There are other [mocking libraries available on crates.io](#), in particular in the area of mocking HTTP services. The other mocking libraries work in a similar fashion as `Mockall`, meaning that they make it easy to get a mock implementation of a given trait.

- Note that mocking is somewhat *controversial*: mocks allow you to completely isolate a test from its dependencies. The immediate result is faster and more stable test execution. On the other hand, the mocks can be configured wrongly and return output different from what the real dependencies would do.

If at all possible, it is recommended that you use the real dependencies. As an example, many databases allow you to configure an in-memory backend. This means that you get the correct behavior in your tests, plus they are fast and will automatically clean up after themselves.

Similarly, many web frameworks allow you to start an in-process server which binds to a random port on localhost. Always prefer this over mocking away the framework since it helps you test your code in the real environment.

- Mockall is not part of the Rust Playground, so you need to run this example in a local environment. Use `cargo add mockall` to quickly add Mockall to an existing Cargo project.
- Mockall has a lot more functionality. In particular, you can set up expectations which depend on the arguments passed. Here we use this to mock a cat which becomes hungry 3 hours after the last time it was fed:

```
fn test_robot_cat() {
    let mut mock_cat = MockPet::new();
    mock_cat
        .expect_is_hungry()
        .with(mockall::predicate::gt(Duration::from_secs(3 * 3600)))
        .return_const(true);
    mock_cat.expect_is_hungry().return_const(false);
    assert_eq!(mock_cat.is_hungry(Duration::from_secs(1 * 3600)), false);
    assert_eq!(mock_cat.is_hungry(Duration::from_secs(5 * 3600)), true);
}
```

- You can use `.times(n)` to limit the number of times a mock method can be called to n --- the mock will automatically panic when dropped if this isn't satisfied.

Bölüm 36

Kayıt Tutma (Logging)

You should use the log crate to automatically log to logcat (on-device) or stdout (on-host):

hello_rust_logs/Android.bp:

```
rust_binary {
    name: "hello_rust_logs",
    crate_name: "hello_rust_logs",
    srcs: ["src/main.rs"],
    rustlibs: [
        "liblog_rust",
        "liblogger",
    ],
    host_supported: true,
}
```

hello_rust_logs/src/main.rs:

```
/// Rust logging demo.

use log::{debug, error, info};

/// Logs a greeting.
fn main() {
    logger::init(
        logger::Config::default()
            .with_tag_on_device("rust")
            .with_max_level(log::LevelFilter::Trace),
    );
    debug!("Starting program.");
    info!("Things are going fine.");
    error!("Something went wrong!");
}
```

Build, push, and run the binary on your device:

```
m hello_rust_logs
adb push "$ANDROID_PRODUCT_OUT/system/bin/hello_rust_logs" /data/local/tmp
```



```
adb shell /data/local/tmp/hello_rust_logs
```

The logs show up in adb logcat:

```
adb logcat -s rust
```

```
09-08 08:38:32.454 2420 2420 D rust: hello_rust_logs: Starting program.
```

```
09-08 08:38:32.454 2420 2420 I rust: hello_rust_logs: Things are going fine.
```

```
09-08 08:38:32.454 2420 2420 E rust: hello_rust_logs: Something went wrong!
```

- The logger implementation in `liblogger` is only needed in the final binary, if you're logging from a library you only need the `log` facade crate.

Bölüm 37

Birlikte Çalışabilirlik

Rust has excellent support for interoperability with other languages. This means that you can:

- Call Rust functions from other languages.
- Call functions written in other languages from Rust.

When you call functions in a foreign language we say that you're using a *foreign function interface*, also known as FFI.

37.1 Interoperability with C

Rust has full support for linking object files with a C calling convention. Similarly, you can export Rust functions and call them from C.

You can do it by hand if you want:

```
unsafe extern "C" {
    safe fn abs(x: i32) -> i32;
}

fn main() {
    let x = -42;
    let abs_x = abs(x);
    println!("{x}, {abs_x}");
}
```

We already saw this in the [Safe FFI Wrapper exercise](#).

This assumes full knowledge of the target platform. Not recommended for production.

We will look at better options next.

37.1.1 Using Bindgen

The `bindgen` tool can auto-generate bindings from a C header file.

First create a small C library:

interoperability/bindgen/libbirthday.h:

```
typedef struct card {
    const char* name;
    int years;
} card;
```

```
void print_card(const card* card);
```

interoperability/bindgen/libbirthday.c:

```
#include <stdio.h>
#include "libbirthday.h"
```

```
void print_card(const card* card) {
    printf("+-----\n");
    printf("| Happy Birthday %s!\n", card->name);
    printf("| Congratulations with the %i years!\n", card->years);
    printf("+-----\n");
}
```

Add this to your `Android.bp` file:

interoperability/bindgen/Android.bp:

```
cc_library {
    name: "libbirthday",
    srcs: ["libbirthday.c"],
}
```

Create a wrapper header file for the library (not strictly needed in this example):

interoperability/bindgen/libbirthday_wrapper.h:

```
#include "libbirthday.h"
```

You can now auto-generate the bindings:

interoperability/bindgen/Android.bp:

```
rust_bindgen {
    name: "libbirthday_bindgen",
    crate_name: "birthday_bindgen",
    wrapper_src: "libbirthday_wrapper.h",
    source_stem: "bindings",
    static_libs: ["libbirthday"],
}
```

Finally, we can use the bindings in our Rust program:

interoperability/bindgen/Android.bp:

```
rust_binary {
    name: "print_birthday_card",
    srcs: ["main.rs"],
    rustlibs: ["libbirthday_bindgen"],
}
```

interoperability/bindgen/main.rs:

```
///! Bindgen demo.

use birthday_bindgen::{card, print_card};

fn main() {
    let name = std::ffi::CString::new("Peter").unwrap();
    let card = card { name: name.as_ptr(), years: 42 };
    // SAFETY: The pointer we pass is valid because it came from a Rust
    // reference, and the `name` it contains refers to `name` above which also
    // remains valid. `print_card` doesn't store either pointer to use later
    // after it returns.
    unsafe {
        print_card(&card as *const card);
    }
}
```

Build, push, and run the binary on your device:

```
m print_birthday_card
adb push "$ANDROID_PRODUCT_OUT/system/bin/print_birthday_card" /data/local/tmp
adb shell /data/local/tmp/print_birthday_card
```

Finally, we can run auto-generated tests to ensure the bindings work:

interoperability/bindgen/Android.bp:

```
rust_test {
    name: "libbirthday_bindgen_test",
    srcs: [":libbirthday_bindgen"],
    crate_name: "libbirthday_bindgen_test",
    test_suites: ["general-tests"],
    auto_gen_config: true,
    clippy_lints: "none", // Generated file, skip linting
    lints: "none",
}

atest libbirthday_bindgen_test
```

37.1.2 Calling Rust

Exporting Rust functions and types to C is easy:

interoperability/rust/libanalyze/analyze.rs

```
///! Rust FFI demo.

use std::os::raw::c_int;

/// Analyze the numbers.
// SAFETY: There is no other global function of this name.
pub extern "C" fn analyze_numbers(x: c_int, y: c_int) {
    if x < y {
        println!("x ({x}) is smallest!");
    }
}
```

```

    } else {
        println!("y ({y}) is probably larger than x ({x})");
    }
}

```

interoperability/rust/libanalyze/analyze.h

```

#ifndef ANALYSE_H
#define ANALYSE_H

void analyze_numbers(int x, int y);

#endif

```

interoperability/rust/libanalyze/Android.bp

```

rust_ffi {
    name: "libanalyze_ffi",
    crate_name: "analyze_ffi",
    srcs: ["analyze.rs"],
    include_dirs: ["."],
}

```

We can now call this from a C binary:

interoperability/rust/analyze/main.c

```

#include "analyze.h"

int main() {
    analyze_numbers(10, 20);
    analyze_numbers(123, 123);
    return 0;
}

```

interoperability/rust/analyze/Android.bp

```

cc_binary {
    name: "analyze_numbers",
    srcs: ["main.c"],
    static_libs: ["libanalyze_ffi"],
}

```

Build, push, and run the binary on your device:

```

m analyze_numbers
adb push "$ANDROID_PRODUCT_OUT/system/bin/analyze_numbers" /data/local/tmp
adb shell /data/local/tmp/analyze_numbers

```

`#[unsafe(no_mangle)]` disables Rust's usual name mangling, so the exported symbol will just be the name of the function. You can also use `#[unsafe(export_name = "some_name")]` to specify whatever name you want.

37.2 C++ ile

The **CXX crate** makes it possible to do safe interoperability between Rust and C++.

The overall approach looks like this:

37.2.1 Köprü Modülü

CXX relies on a description of the function signatures that will be exposed from each language to the other. You provide this description using extern blocks in a Rust module annotated with the `#[cxx::bridge]` attribute macro.

```
mod ffi {
    // Shared structs with fields visible to both languages.
    struct BlobMetadata {
        size: usize,
        tags: Vec<String>,
    }

    // Rust types and signatures exposed to C++.
    extern "Rust" {
        type MultiBuf;

        fn next_chunk(buf: &mut MultiBuf) -> &[u8];
    }

    // C++ types and signatures exposed to Rust.
    unsafe extern "C++" {
        include!("include/blobstore.h");

        type BlobstoreClient;

        fn new_blobstore_client() -> UniquePtr<BlobstoreClient>;
        fn put(self: Pin<&mut BlobstoreClient>, parts: &mut MultiBuf) -> u64;
        fn tag(self: Pin<&mut BlobstoreClient>, blobid: u64, tag: &str);
        fn metadata(&self, blobid: u64) -> BlobMetadata;
    }
}
```

- The bridge is generally declared in an ffi module within your crate.
- From the declarations made in the bridge module, CXX will generate matching Rust and C++ type/function definitions in order to expose those items to both languages.
- To view the generated Rust code, use `cargo-expand` to view the expanded proc macro. For most of the examples you would use `cargo expand ::ffi` to expand just the ffi module (though this doesn't apply for Android projects).
- To view the generated C++ code, look in `target/cxxbridge`.

37.2.2 Rust Bridge Declarations

```
mod ffi {
    extern "Rust" {
        type MyType; // Opaque type
        fn foo(&self); // Method on `MyType`
        fn bar() -> Box<MyType>; // Free function
    }
}
```

```

}

struct MyType(i32);

impl MyType {
    fn foo(&self) {
        println!("{}", self.0);
    }
}

fn bar() -> Box<MyType> {
    Box::new(MyType(123))
}

```

- Items declared in the `extern "Rust"` reference items that are in scope in the parent module.
- The CXX code generator uses your `extern "Rust"` section(s) to produce a C++ header file containing the corresponding C++ declarations. The generated header has the same path as the Rust source file containing the bridge, except with a `.rs.h` file extension.

37.2.3 Oluşturulan (Generated) C++

```

mod ffi {
    // Rust types and signatures exposed to C++.
    extern "Rust" {
        type MultiBuf;

        fn next_chunk(buf: &mut MultiBuf) -> &[u8];
    }
}

```

Results in (roughly) the following C++:

```

struct MultiBuf final : public ::rust::Opaque {
    ~MultiBuf() = delete;

private:
    friend ::rust::layout;
    struct layout {
        static ::std::size_t size() noexcept;
        static ::std::size_t align() noexcept;
    };
};

::rust::Slice<::std::uint8_t const> next_chunk(::org::blobstore::MultiBuf &buf) noexcept

```

37.2.4 C++ Bridge Declarations

```

mod ffi {
    // C++ types and signatures exposed to Rust.
    unsafe extern "C++" {
        include!("include/blobstore.h");
    }
}

```

```

    type BlobstoreClient;

    fn new_blobstore_client() -> UniquePtr<BlobstoreClient>;
    fn put(self: Pin<&mut BlobstoreClient>, parts: &mut MultiBuf) -> u64;
    fn tag(self: Pin<&mut BlobstoreClient>, blobid: u64, tag: &str);
    fn metadata(&self, blobid: u64) -> BlobMetadata;
}
}

```

Results in (roughly) the following Rust:

```

pub struct BlobstoreClient {
    _private: ::cxx::private::Opaque,
}

pub fn new_blobstore_client() -> ::cxx::UniquePtr<BlobstoreClient> {
    extern "C" {
        fn __new_blobstore_client() -> *mut BlobstoreClient;
    }
    unsafe { ::cxx::UniquePtr::from_raw(__new_blobstore_client()) }
}

impl BlobstoreClient {
    pub fn put(&self, parts: &mut MultiBuf) -> u64 {
        extern "C" {
            fn __put(
                _: &BlobstoreClient,
                parts: *mut ::cxx::core::ffi::c_void,
            ) -> u64;
        }
        unsafe {
            __put(self, parts as *mut MultiBuf as *mut ::cxx::core::ffi::c_void)
        }
    }
}

// ...

```

- The programmer does not need to promise that the signatures they have typed in are accurate. CXX performs static assertions that the signatures exactly correspond with what is declared in C++.
- `unsafe extern` blocks allow you to declare C++ functions that are safe to call from Rust.

37.2.5 Paylaşılan (Shared) Türler

```

mod ffi {
    struct PlayingCard {
        suit: Suit,
        value: u8, // A=1, J=11, Q=12, K=13
    }
}

```



```

enum Suit {
    Clubs,
    Diamonds,
    Hearts,
    Spades,
}
}

```

- Only C-like (unit) enums are supported.
- A limited number of traits are supported for `#[derive()]` on shared types. Corresponding functionality is also generated for the C++ code, e.g. if you derive `Hash` also generates an implementation of `std::hash` for the corresponding C++ type.

37.2.6 Paylaşılan (Shared) Enum'lar

```

mod ffi {
    enum Suit {
        Clubs,
        Diamonds,
        Hearts,
        Spades,
    }
}

```

Oluşturulan (Generated) Rust:

```

pub struct Suit {
    pub repr: u8,
}

impl Suit {
    pub const Clubs: Self = Suit { repr: 0 };
    pub const Diamonds: Self = Suit { repr: 1 };
    pub const Hearts: Self = Suit { repr: 2 };
    pub const Spades: Self = Suit { repr: 3 };
}

```

Generated C++:

```

enum class Suit : uint8_t {
    Clubs = 0,
    Diamonds = 1,
    Hearts = 2,
    Spades = 3,
};

```

- On the Rust side, the code generated for shared enums is actually a struct wrapping a numeric value. This is because it is not UB in C++ for an enum class to hold a value different from all of the listed variants, and our Rust representation needs to have the same behavior.

37.2.7 Rust Hata İşleme

```
mod ffi {
    extern "Rust" {
        fn fallible(depth: usize) -> Result<String>;
    }
}

fn fallible(depth: usize) -> anyhow::Result<String> {
    if depth == 0 {
        return Err(anyhow::Error::msg("fallible1 requires depth > 0"));
    }

    Ok("Success!".into())
}
```

- Rust functions that return `Result` are translated to exceptions on the C++ side.
- The exception thrown will always be of type `rust::Error`, which primarily exposes a way to get the error message string. The error message will come from the error type's `Display` impl.
- A panic unwinding from Rust to C++ will always cause the process to immediately terminate.

37.2.8 C++ Hata İşleme

```
mod ffi {
    unsafe extern "C++" {
        include!("example/include/example.h");
        fn fallible(depth: usize) -> Result<String>;
    }
}

fn main() {
    if let Err(err) = ffi::fallible(99) {
        eprintln!("Error: {}", err);
        process::exit(1);
    }
}
```

- C++ functions declared to return a `Result` will catch any thrown exception on the C++ side and return it as an `Err` value to the calling Rust function.
- If an exception is thrown from an `extern "C++"` function that is not declared by the CXX bridge to return `Result`, the program calls C++'s `std::terminate`. The behavior is equivalent to the same exception being thrown through a `noexcept` C++ function.

37.2.9 Ek Türler

Rust Türü	C++ Türü
String	rust::String
&str	rust::Str

Rust Türü	C++ Türü
CxxString	std::string
&[T]/&mut [T]	rust::Slice
Box<T>	rust::Box<T>
UniquePtr<T>	std::unique_ptr<T>
Vec<T>	rust::Vec<T>
CxxVector<T>	std::vector<T>

- These types can be used in the fields of shared structs and the arguments and returns of extern functions.
- Note that Rust's String does not map directly to std::string. There are a few reasons for this:
 - std::string does not uphold the UTF-8 invariant that String requires.
 - The two types have different layouts in memory and so can't be passed directly between languages.
 - std::string requires move constructors that don't match Rust's move semantics, so a std::string can't be passed by value to Rust.

37.2.10 Android'de İnşa Etme (Build)

Create a cc_library_static to build the C++ library, including the CXX generated header and source file.

```
cc_library_static {
    name: "libcxx_test_cpp",
    srcs: ["cxx_test.cpp"],
    generated_headers: [
        "cxx-bridge-header",
        "libcxx_test_bridge_header"
    ],
    generated_sources: ["libcxx_test_bridge_code"],
}
```

- Point out that libcxx_test_bridge_header and libcxx_test_bridge_code are the dependencies for the CXX-generated C++ bindings. We'll show how these are setup on the next slide.
- Note that you also need to depend on the cxx-bridge-header library in order to pull in common CXX definitions.
- Full docs for using CXX in Android can be found in [the Android docs](#). You may want to share that link with the class so that students know where they can find these instructions again in the future.

37.2.11 Android'de İnşa Etme (Build)

Create two genrules: One to generate the CXX header, and one to generate the CXX source file. These are then used as inputs to the cc_library_static.

```
// Generate a C++ header containing the C++ bindings
// to the Rust exported functions in lib.rs.
genrule {
    name: "libcxx_test_bridge_header",
```

```

    tools: ["cxxbridge"],
    cmd: "$(location cxxbridge) $(in) --header > $(out)",
    srcs: ["lib.rs"],
    out: ["lib.rs.h"],
}

// Generate the C++ code that Rust calls into.
genrule {
    name: "libcxx_test_bridge_code",
    tools: ["cxxbridge"],
    cmd: "$(location cxxbridge) $(in) > $(out)",
    srcs: ["lib.rs"],
    out: ["lib.rs.cc"],
}

```

- The `cxxbridge` tool is a standalone tool that generates the C++ side of the bridge module. It is included in Android and available as a Soong tool.
- By convention, if your Rust source file is `lib.rs` your header file will be named `lib.rs.h` and your source file will be named `lib.rs.cc`. This naming convention isn't enforced, though.

37.2.12 Android'de İnşa Etme (Build)

Create a `rust_binary` that depends on `libcxx` and your `cc_library_static`.

```

rust_binary {
    name: "cxx_test",
    srcs: ["lib.rs"],
    rustlibs: ["libcxx"],
    static_libs: ["libcxx_test_cpp"],
}

```

37.3 Interoperability with Java

Java can load shared objects via [Java Native Interface \(JNI\)](#). The `jni` crate allows you to create a compatible library.

First, we create a Rust function to export to Java:

interoperability/java/src/lib.rs:

```

///! Rust <-> Java FFI demo.

use jni::objects::{JClass, JString};
use jni::sys::jstring;
use jni::JNIEnv;

/// HelloWorld::hello method implementation.
// SAFETY: There is no other global function of this name.
pub extern "system" fn Java_HelloWorld_hello(
    mut env: JNIEnv,
    _class: JClass,

```

```

    name: JString,
) -> jstring {
    let input: String = env.get_string(&name).unwrap().into();
    let greeting = format!("Merhaba, {input}!");
    let output = env.new_string(greeting).unwrap();
    output.into_raw()
}

```

interoperability/java/Android.bp:

```

rust_ffi_shared {
    name: "libhello_jni",
    crate_name: "hello_jni",
    srcs: ["src/lib.rs"],
    rustlibs: ["libjni"],
}

```

We then call this function from Java:

interoperability/java/HelloWorld.java:

```

class HelloWorld {
    private static native String hello(String name);

    static {
        System.loadLibrary("hello_jni");
    }

    public static void main(String[] args) {
        String output = HelloWorld.hello("Alice");
        System.out.println(output);
    }
}

```

interoperability/java/Android.bp:

```

java_binary {
    name: "helloworld_jni",
    srcs: ["HelloWorld.java"],
    main_class: "HelloWorld",
    required: ["libhello_jni"],
}

```

Finally, you can build, sync, and run the binary:

```

m helloworld_jni
adb sync # requires adb root && adb remount
adb shell /system/bin/helloworld_jni

```

- The `unsafe(no_mangle)` attribute instructs Rust to emit the `Java_HelloWorld_hello` symbol exactly as written. This is important so that Java can recognize the symbol as a `hello` method on the `HelloWorld` class.
 - By default, Rust will mangle (rename) symbols so that a binary can link in two versions of the same Rust crate.

Kısım X

Chromium

Bölüm 38

Chromium'daki Rust'a Hoş Geldiniz

Rust is supported for third-party libraries in Chromium, with first-party glue code to connect between Rust and existing Chromium C++ code.

Today, we'll call into Rust to do something silly with strings. If you've got a corner of the code where you're displaying a UTF8 string to the user, feel free to follow this recipe in your part of the codebase instead of the exact part we talk about.

Bölüm 39

Kurulum (Setup)

Make sure you can build and run Chromium. Any platform and set of build flags is OK, so long as your code is relatively recent (commit position 1223636 onwards, corresponding to November 2023):

```
gn gen out/Debug
autoninja -C out/Debug chrome
out/Debug/chrome # or on Mac, out/Debug/Chromium.app/Contents/MacOS/Chromium
```

(A component, debug build is recommended for quickest iteration time. This is the default!)

See [How to build Chromium](#) if you aren't already at that point. Be warned: setting up to build Chromium takes time.

It's also recommended that you have Visual Studio code installed.

Alıřtırmalar hakkında

This part of the course has a series of exercises which build on each other. We'll be doing them spread throughout the course instead of just at the end. If you don't have time to complete a certain part, don't worry: you can catch up in the next slot.

Bölüm 40

Chromium ve Cargo Ekosistemlerinin Karşılaştırılması

The Rust community typically uses cargo and libraries from crates.io. Chromium is built using gn and ninja and a curated set of dependencies.

When writing code in Rust, your choices are:

- Use gn and ninja with the help of the templates from `//build/rust/*.gni` (e.g. `rust_static_library` that we'll meet later). This uses Chromium's audited toolchain and crates.
- Use cargo, but **restrict yourself to Chromium's audited toolchain and crates**
- Use cargo, trusting a **toolchain** and/or **crates downloaded from the internet**

From here on we'll be focusing on gn and ninja, because this is how Rust code can be built into the Chromium browser. At the same time, Cargo is an important part of the Rust ecosystem and you should keep it in your toolbox.

Küçük bir alıştırma

Split into small groups and:

- Brainstorm scenarios where cargo may offer an advantage and assess the risk profile of these scenarios.
- Discuss which tools, libraries, and groups of people need to be trusted when using gn and ninja, offline cargo, etc.

Ask students to avoid peeking at the speaker notes before completing the exercise. Assuming folks taking the course are physically together, ask them to discuss in small groups of 3-4 people.

Notes/hints related to the first part of the exercise ("scenarios where Cargo may offer an advantage"):

- It's fantastic that when writing a tool, or prototyping a part of Chromium, one has access to the rich ecosystem of crates.io libraries. There is a crate for almost anything and they are usually quite pleasant to use. (`clap` for command-line parsing, `serde` for

serializing/deserializing to/from various formats, `itertools` for working with iterators, etc.).

- `cargo` makes it easy to try a library (just add a single line to `Cargo.toml` and start writing code)
- It may be worth comparing how CPAN helped make `perl` a popular choice. Or comparing with `python + pip`.
- Development experience is made really nice not only by core Rust tools (e.g. using `rustup` to switch to a different `rustc` version when testing a crate that needs to work on nightly, current stable, and older stable) but also by an ecosystem of third-party tools (e.g. Mozilla provides `cargo vet` for streamlining and sharing security audits; `criterion` crate gives a streamlined way to run benchmarks).
 - `cargo` makes it easy to add a tool via `cargo install --locked cargo-vet`.
 - It may be worth comparing with Chrome Extensions or VScode extensions.
- Broad, generic examples of projects where `cargo` may be the right choice:
 - Perhaps surprisingly, Rust is becoming increasingly popular in the industry for writing command line tools. The breadth and ergonomics of libraries is comparable to Python, while being more robust (thanks to the rich typesystem) and running faster (as a compiled, rather than interpreted language).
 - Participating in the Rust ecosystem requires using standard Rust tools like `Cargo`. Libraries that want to get external contributions, and want to be used outside of Chromium (e.g. in Bazel or Android/Soong build environments) should probably use `Cargo`.
- Examples of Chromium-related projects that are `cargo`-based:
 - `serde_json_lenient` (experimented with in other parts of Google which resulted in PRs with performance improvements)
 - Fontations libraries like `font-types`
 - `gnrt` tool (we will meet it later in the course) which depends on `clap` for command-line parsing and on `toml` for configuration files.
 - * Disclaimer: a unique reason for using `cargo` was unavailability of `gn` when building and bootstrapping Rust standard library when building Rust toolchain.
 - * `run_gnrt.py` uses Chromium's copy of `cargo` and `rustc`. `gnrt` depends on third-party libraries downloaded from the internet, but `run_gnrt.py` asks `cargo` that only `--locked` content is allowed via `Cargo.lock`.)

Students may identify the following items as being implicitly or explicitly trusted:

- `rustc` (the Rust compiler) which in turn depends on the LLVM libraries, the Clang compiler, the `rustc` sources (fetched from GitHub, reviewed by Rust compiler team), binary Rust compiler downloaded for bootstrapping
- `rustup` (it may be worth pointing out that `rustup` is developed under the umbrella of the <https://github.com/rust-lang/organization> - same as `rustc`)
- `cargo`, `rustfmt`, etc.
- Various internal infrastructure (bots that build `rustc`, system for distributing the prebuilt toolchain to Chromium engineers, etc.)
- `Cargo` tools like `cargo audit`, `cargo vet`, etc.
- Rust libraries vendored into `//third_party/rust` (audited by `security@chromium.org`)
- Other Rust libraries (some niche, some quite popular and commonly used)

Bölüm 42

İnşa (Build) Kuralları

Rust code is usually built using `cargo`. Chromium builds with `gn` and `ninja` for efficiency --- its static rules allow maximum parallelism. Rust is no exception.

Adding Rust code to Chromium

In some existing Chromium `BUILD.gn` file, declare a `rust_static_library`:

```
import("//build/rust/rust_static_library.gni")

rust_static_library("my_rust_lib") {
  crate_root = "lib.rs"
  sources = [ "lib.rs" ]
}
```

You can also add `deps` on other Rust targets. Later we'll use this to depend upon third party code.

You must specify *both* the crate root, *and* a full list of sources. The `crate_root` is the file given to the Rust compiler representing the root file of the compilation unit --- typically `lib.rs`. `sources` is a complete list of all source files which `ninja` needs in order to determine when rebuilds are necessary.

(There's no such thing as a Rust `source_set`, because in Rust, an entire crate is a compilation unit. A `static_library` is the smallest unit.)

Students might be wondering why we need a `gn` template, rather than using [gn's built-in support for Rust static libraries](#). The answer is that this template provides support for CXX interop, Rust features, and unit tests, some of which we'll use later.

42.1 Including unsafe Rust Code

Unsafe Rust code is forbidden in `rust_static_library` by default --- it won't compile. If you need unsafe Rust code, add `allow_unsafe = true` to the `gn` target. (Later in the course we'll see circumstances where this is necessary.)

```
import("//build/rust/rust_static_library.gni")

rust_static_library("my_rust_lib") {
  crate_root = "lib.rs"
  sources = [
    "lib.rs",
    "hippopotamus.rs"
  ]
  allow_unsafe = true
}
```

42.2 Chromium C++'dan Rust Koduna Bağımlılık

Simply add the above target to the deps of some Chromium C++ target.

```
import("//build/rust/rust_static_library.gni")

rust_static_library("my_rust_lib") {
  crate_root = "lib.rs"
  sources = [ "lib.rs" ]
}

# or source_set, static_library etc.
component("preexisting_cpp") {
  deps = [ ":my_rust_lib" ]
}
```

42.3 Visual Studio Code

Types are elided in Rust code, which makes a good IDE even more useful than for C++. Visual Studio code works well for Rust in Chromium. To use it,

- Ensure your VSCode has the `rust-analyzer` extension, not earlier forms of Rust support
- `gn gen out/Debug --export-rust-project` (or equivalent for your output directory)
- `ln -s out/Debug/rust-project.json rust-project.json`

A demo of some of the code annotation and exploration features of `rust-analyzer` might be beneficial if the audience are naturally skeptical of IDEs.

The following steps may help with the demo (but feel free to instead use a piece of Chromium-related Rust that you are most familiar with):

- Open `components/qr_code_generator/qr_code_generator_ffi_glue.rs`
- Place the cursor over the `QrCode::new` call (around line 26) in `qr_code_generator_ffi_glue.rs`
- Demo **show documentation** (typical bindings: `vscode = ctrl k i`; `vim/CoC = K`).
- Demo **go to definition** (typical bindings: `vscode = F12`; `vim/CoC = g d`). (This will take you to `//third_party/rust/.../qr_code-.../src/lib.rs`.)
- Demo **outline** and navigate to the `QrCode::with_bits` method (around line 164; the outline is in the file explorer pane in `vscode`; typical `vim/CoC` bindings = `space o`)

- Demo **type annotations** (there are quite a few nice examples in the `QrCode::with_bits` method)

It may be worth pointing out that `gn gen ... --export-rust-project` will need to be rerun after editing `BUILD.gn` files (which we will do a few times throughout the exercises in this session).

42.4 İnşa (build) kuralları alıştırmaları

In your Chromium build, add a new Rust target to `//ui/base/BUILD.gn` containing:

```
// SAFETY: There is no other global function of this name.
pub extern "C" fn hello_from_rust() {
    println!("Rust dilinden merhaba!")
}
```

Important: note that `no_mangle` here is considered a type of unsafety by the Rust compiler, so you'll need to allow unsafe code in your `gn` target.

Add this new Rust target as a dependency of `//ui/base:base`. Declare this function at the top of `ui/base/resource/resource_bundle.cc` (later, we'll see how this can be automated by bindings generation tools):

```
extern "C" void hello_from_rust();
```

Call this function from somewhere in `ui/base/resource/resource_bundle.cc` - we suggest the top of `ResourceBundle::MaybeMangleLocalizedString`. Build and run Chromium, and ensure that "Hello from Rust!" is printed lots of times.

If you use VSCode, now set up Rust to work well in VSCode. It will be useful in subsequent exercises. If you've succeeded, you will be able to use right-click "Go to definition" on `println!`.

Where to find help

- The options available to the [rust_static_library gn template](#)
- Information about `#[unsafe(no_mangle)]`
- Information about `extern "C"`
- Information about `gn's --export-rust-project` switch
- [How to install rust-analyzer in VSCode](#)

This example is unusual because it boils down to the lowest-common-denominator interop language, C. Both C++ and Rust can natively declare and call C ABI functions. Later in the course, we'll connect C++ directly to Rust.

`allow_unsafe = true` is required here because `#[unsafe(no_mangle)]` might allow Rust to generate two functions with the same name, and Rust can no longer guarantee that the right one is called.

If you need a pure Rust executable, you can also do that using the `rust_executable` `gn` template.

Bölüm 43

Test Etme

Rust community typically authors unit tests in a module placed in the same source file as the code being tested. This was covered [earlier](#) in the course and looks like this:

```
mod tests {  
    fn my_test() {  
        todo!()  
    }  
}
```

In Chromium we place unit tests in a separate source file and we continue to follow this practice for Rust --- this makes tests consistently discoverable and helps to avoid rebuilding .rs files a second time (in the test configuration).

This results in the following options for testing Rust code in Chromium:

- Native Rust tests (i.e. `#[test]`). Discouraged outside of `//third_party/rust`.
- `gtest` tests authored in C++ and exercising Rust via FFI calls. Sufficient when Rust code is just a thin FFI layer and the existing unit tests provide sufficient coverage for the feature.
- `gtest` tests authored in Rust and using the crate under test through its public API (using `pub mod for_testing { ... }` if needed). This is the subject of the next few slides.

Mention that native Rust tests of third-party crates should eventually be exercised by Chromium bots. (Such testing is needed rarely --- only after adding or updating third-party crates.)

Some examples may help illustrate when C++ `gtest` vs Rust `gtest` should be used:

- QR has very little functionality in the first-party Rust layer (it's just a thin FFI glue) and therefore uses the existing C++ unit tests for testing both the C++ and the Rust implementation (parameterizing the tests so they enable or disable Rust using a `ScopedFeatureList`).
- Hypothetical/WIP PNG integration may need to implement memory-safe implementation of pixel transformations that are provided by `libpng` but missing in the `png` crate - e.g. `RGBA => BGRA`, or gamma correction. Such functionality may benefit from separate tests authored in Rust.

43.1 rust_gtest_interop Kütüphanesi

The `rust_gtest_interop` library provides a way to:

- Use a Rust function as a gtest testcase (using the `#[gtest(...)]` attribute)
- Use `expect_eq!` and similar macros (similar to `assert_eq!` but not panicking and not terminating the test when the assertion fails).

Örnek:

```
use rust_gtest_interop::prelude::*;

fn test_addition() {
    expect_eq!(2 + 2, 4);
}
```

43.2 Rust Testleri için GN Kuralları

The simplest way to build Rust gtest tests is to add them to an existing test binary that already contains tests authored in C++. For example:

```
test("ui_base_unittests") {
    ...
    sources += [ "my_rust_lib_unittest.rs" ]
    deps += [ ":my_rust_lib" ]
}
```

Authoring Rust tests in a separate `static_library` also works, but requires manually declaring the dependency on the support libraries:

```
rust_static_library("my_rust_lib_unittests") {
    testonly = true
    is_gtest_unittests = true
    crate_root = "my_rust_lib_unittest.rs"
    sources = [ "my_rust_lib_unittest.rs" ]
    deps = [
        ":my_rust_lib",
        "//testing/rust_gtest_interop",
    ]
}

test("ui_base_unittests") {
    ...
    deps += [ ":my_rust_lib_unittests" ]
}
```

43.3 chromium::import! Makrosu

After adding `:my_rust_lib` to GN deps, we still need to learn how to import and use `my_rust_lib` from `my_rust_lib_unittest.rs`. We haven't provided an explicit `crate_name` for `my_rust_lib` so its crate name is computed based on the full target path

and name. Fortunately we can avoid working with such an unwieldy name by using the `chromium::import!` macro from the automatically-imported `chromium` crate:

```
chromium::import! {  
    "//ui/base:my_rust_lib";  
}
```

```
use my_rust_lib::my_function_under_test;
```

Under the covers the macro expands to something similar to:

```
extern crate ui_sbase_cmy_urust_ulib as my_rust_lib;
```

```
use my_rust_lib::my_function_under_test;
```

More information can be found in [the doc comment](#) of the `chromium::import` macro.

`rust_static_library` supports specifying an explicit name via `crate_name` property, but doing this is discouraged. And it is discouraged because the crate name has to be globally unique. `crates.io` guarantees uniqueness of its crate names so `cargo_crate` GN targets (generated by the `gnrt` tool covered in a later section) use short crate names.

43.4 Testing exercise

Time for another exercise!

In your Chromium build:

- Add a testable function next to `hello_from_rust`. Some suggestions: adding two integers received as arguments, computing the *n*th Fibonacci number, summing integers in a slice, etc.
- Add a separate `..._unittest.rs` file with a test for the new function.
- Add the new tests to `BUILD.gn`.
- Build the tests, run them, and verify that the new test works.

Bölüm 44

C++ ile Birlikte Çalışabilirlik

The Rust community offers multiple options for C++/Rust interop, with new tools being developed all the time. At the moment, Chromium uses a tool called CXX.

You describe your whole language boundary in an interface definition language (which looks a lot like Rust) and then CXX tools generate declarations for functions and types in both Rust and C++.

See the [CXX tutorial](#) for a full example of using this.

Talk through the diagram. Explain that behind the scenes, this is doing just the same as you previously did. Point out that automating the process has the following benefits:

- The tool guarantees that the C++ and Rust sides match (e.g. you get compile errors if the `#[cxx::bridge]` doesn't match the actual C++ or Rust definitions, but with out-of-sync manual bindings you'd get Undefined Behavior)
- The tool automates generation of FFI thunks (small, C-ABI-compatible, free functions) for non-C features (e.g. enabling FFI calls into Rust or C++ methods; manual bindings would require authoring such top-level, free functions manually)
- The tool and the library can handle a set of core types - for example:
 - `&[T]` can be passed across the FFI boundary, even though it doesn't guarantee any particular ABI or memory layout. With manual bindings `std::span<T> / &[T]` have to be manually deconstructed and rebuilt out of a pointer and length - this is error-prone given that each language represents empty slices slightly differently)
 - Smart pointers like `std::unique_ptr<T>`, `std::shared_ptr<T>`, and/or `Box` are natively supported. With manual bindings, one would have to pass C-ABI-compatible raw pointers, which would increase lifetime and memory-safety risks.
 - `rust::String` and `CxxString` types understand and maintain differences in string representation across the languages (e.g. `rust::String::lossy` can build a Rust string from non-UTF8 input and `rust::String::c_str` can NUL-terminate a string).

44.1 Bağlamalara Örnek

CXX requires that the whole C++/Rust boundary is declared in `cxx::bridge` modules inside `.rs` source code.

```
mod ffi {
    extern "Rust" {
        type MultiBuf;

        fn next_chunk(buf: &mut MultiBuf) -> &[u8];
    }

    unsafe extern "C++" {
        include!("example/include/blobstore.h");

        type BlobstoreClient;

        fn new_blobstore_client() -> UniquePtr<BlobstoreClient>;
        fn put(self: &BlobstoreClient, buf: &mut MultiBuf) -> Result<u64>;
    }
}

// Definitions of Rust types and functions go here
```

Point out:

- Although this looks like a regular Rust mod, the `#[cxx::bridge]` procedural macro does complex things to it. The generated code is quite a bit more sophisticated - though this does still result in a mod called `ffi` in your code.
- Native support for C++'s `std::unique_ptr` in Rust
- Native support for Rust slices in C++
- Calls from C++ to Rust, and Rust types (in the top part)
- Calls from Rust to C++, and C++ types (in the bottom part)

Common misconception: It *looks* like a C++ header is being parsed by Rust, but this is misleading. This header is never interpreted by Rust, but simply `#included` in the generated C++ code for the benefit of C++ compilers.

CXX'in Sınırlamaları

By far the most useful page when using CXX is the [type reference](#).

CXX fundamentally suits cases where:

- Your Rust-C++ interface is sufficiently simple that you can declare all of it.
- You're using only the types natively supported by CXX already, for example `std::unique_ptr`, `std::string`, `&[u8]` etc.

It has many limitations --- for example lack of support for Rust's `Option` type.

These limitations constrain us to using Rust in Chromium only for well isolated "leaf nodes" rather than for arbitrary Rust-C++ interop. When considering a use-case for Rust in Chromium, a good starting point is to draft the CXX bindings for the language boundary to see if it appears simple enough.

You should also discuss some of the other sticky points with CXX, for example:

- Its error handling is based around C++ exceptions (given on the next slide)
- Function pointers are awkward to use.

44.2 CXX Hata İşleme

CXX's `support for Result<T, E>` relies on C++ exceptions, so we can't use that in Chromium. Alternatives:

- The T part of `Result<T, E>` can be:
 - Returned via out parameters (e.g. via `&mut T`). This requires that T can be passed across the FFI boundary - for example T has to be:
 - * A primitive type (like `u32` or `usize`)
 - * A type natively supported by `cxx` (like `UniquePtr<T>`) that has a suitable default value to use in a failure case (*unlike* `Box<T>`).
 - Retained on the Rust side, and exposed via reference. This may be needed when T is a Rust type, which cannot be passed across the FFI boundary, and cannot be stored in `UniquePtr<T>`.
- The E part of `Result<T, E>` can be:
 - Returned as a boolean (e.g. `true` representing success, and `false` representing failure)
 - Preserving error details is in theory possible, but so far hasn't been needed in practice.

44.2.1 CXX Error Handling: QR Example

The QR code generator is **an example** where a boolean is used to communicate success vs failure, and where the successful result can be passed across the FFI boundary:

```
mod ffi {
    extern "Rust" {
        fn generate_qr_code_using_rust(
            data: &[u8],
            min_version: i16,
            out_pixels: Pin<&mut CxxVector<u8>>,
            out_qr_size: &mut usize,
        ) -> bool;
    }
}
```

Students may be curious about the semantics of the `out_qr_size` output. This is not the size of the vector, but the size of the QR code (and admittedly it is a bit redundant - this is the square root of the size of the vector).

It may be worth pointing out the importance of initializing `out_qr_size` before calling into the Rust function. Creation of a Rust reference that points to uninitialized memory results in Undefined Behavior (unlike in C++, when only the act of dereferencing such memory results in UB).

If students ask about `Pin`, then explain why CXX needs it for mutable references to C++ data: the answer is that C++ data can't be moved around like Rust data, because it may contain self-referential pointers.

44.2.2 CXX Error Handling: PNG Example

A prototype of a PNG decoder illustrates what can be done when the successful result cannot be passed across the FFI boundary:

```
mod ffi {
    extern "Rust" {
        /// This returns an FFI-friendly equivalent of `Result<PngReader<'a>,
        /// (>`.
        fn new_png_reader<'a>(input: &'a [u8]) -> Box<ResultOfPngReader<'a>>;

        /// C++ bindings for the `crate::png::ResultOfPngReader` type.
        type ResultOfPngReader<'a>;
        fn is_err(self: &ResultOfPngReader) -> bool;
        fn unwrap_as_mut<'a, 'b>(
            self: &'b mut ResultOfPngReader<'a>,
        ) -> &'b mut PngReader<'a>;

        /// C++ bindings for the `crate::png::PngReader` type.
        type PngReader<'a>;
        fn height(self: &PngReader) -> u32;
        fn width(self: &PngReader) -> u32;
        fn read_rgba8(self: &mut PngReader, output: &mut [u8]) -> bool;
    }
}
```

`PngReader` and `ResultOfPngReader` are Rust types --- objects of these types cannot cross the FFI boundary without indirection of a `Box<T>`. We can't have an `out_parameter: &mut PngReader`, because CXX doesn't allow C++ to store Rust objects by value.

This example illustrates that even though CXX doesn't support arbitrary generics nor templates, we can still pass them across the FFI boundary by manually specializing / monomorphizing them into a non-generic type. In the example `ResultOfPngReader` is a non-generic type that forwards into appropriate methods of `Result<T, E>` (e.g. into `is_err`, `unwrap`, and/or `as_mut`).

Using cxx in Chromium

In Chromium, we define an independent `#[cxx::bridge] mod` for each leaf-node where we want to use Rust. You'd typically have one for each `rust_static_library`. Just add

```
cxx_bindings = [ "my_rust_file.rs" ]
# list of files containing #[cxx::bridge], not all source files
allow_unsafe = true
```

to your existing `rust_static_library` target alongside `crate_root` and `sources`.

C++ headers will be generated at a sensible location, so you can just

```
#include "ui/base/my_rust_file.rs.h"
```

You will find some utility functions in `//base` to convert to/from Chromium C++ types to CXX Rust types --- for example `SpanToRustSlice`.

Students may ask --- why do we still need `allow_unsafe = true`?

The broad answer is that no C/C++ code is "safe" by the normal Rust standards. Calling back and forth to C/C++ from Rust may do arbitrary things to memory, and compromise the safety of Rust's own data layouts. Presence of *too many* `unsafe` keywords in C/C++ interop can harm the signal-to-noise ratio of such a keyword, and is **controversial**, but strictly, bringing any foreign code into a Rust binary can cause unexpected behavior from Rust's perspective.

The narrow answer lies in the diagram at the top of [this page](#) --- behind the scenes, CXX generates Rust `unsafe` and `extern "C"` functions just like we did manually in the previous section.

44.3 Alıştırma: C++ ile Birlikte Çalışabilirlik

Part one

- In the Rust file you previously created, add a `#[cxx::bridge]` which specifies a single function, to be called from C++, called `hello_from_rust`, taking no parameters and returning no value.
- Modify your previous `hello_from_rust` function to remove `extern "C"` and `#[unsafe(no_mangle)]`. This is now just a standard Rust function.
- Modify your `gn` target to build these bindings.
- In your C++ code, remove the forward-declaration of `hello_from_rust`. Instead, include the generated header file.
- İnşa et (Build) ve çalıştır!

Part two

It's a good idea to play with CXX a little. It helps you think about how flexible Rust in Chromium actually is.

Some things to try:

- Call back into C++ from Rust. You will need:
 - An additional header file which you can `include!` from your `cxx::bridge`. You'll need to declare your C++ function in that new header file.
 - An `unsafe` block to call such a function, or alternatively specify the `unsafe` keyword in your `#[cxx::bridge]` **as described here**.
 - You may also need to `#include "third_party/rust/cxx/v1/crate/include/cxx.h"`
- Pass a C++ string from C++ into Rust.
- Pass a reference to a C++ object into Rust.
- Intentionally get the Rust function signatures mismatched from the `#[cxx::bridge]`, and get used to the errors you see.
- Intentionally get the C++ function signatures mismatched from the `#[cxx::bridge]`, and get used to the errors you see.
- Pass a `std::unique_ptr` of some type from C++ into Rust, so that Rust can own some C++ object.
- Create a Rust object and pass it into C++, so that C++ owns it. (Hint: you need a `Box`).
- Declare some methods on a C++ type. Call them from Rust.

- Declare some methods on a Rust type. Call them from C++.

Part three

Now you understand the strengths and limitations of CXX interop, think of a couple of use-cases for Rust in Chromium where the interface would be sufficiently simple. Sketch how you might define that interface.

Where to find help

- The [cxx binding reference](#)
- The [rust_static_library gn template](#)

Some of the questions you may encounter:

- I'm seeing a problem initializing a variable of type X with type Y, where X and Y are both function types. This is because your C++ function doesn't quite match the declaration in your `cxx::bridge`.
- I seem to be able to freely convert C++ references into Rust references. Doesn't that risk UB? For CXX's *opaque* types, no, because they are zero-sized. For CXX trivial types yes, it's *possible* to cause UB, although CXX's design makes it quite difficult to craft such an example.

Bölüm 45

Üçüncü Taraf Kasalarını Eklenmesi

Rust libraries are called "crates" and are found at crates.io. It's *very easy* for Rust crates to depend upon one another. So they do!

Property	C++ kütüphanesi	Rust crate
Build system	Lots	Consistent: Cargo.toml
Typical library size	Large-ish	Small
Transitive dependencies	Few	Lots

For a Chromium engineer, this has pros and cons:

- All crates use a common build system so we can automate their inclusion into Chromium...
- ... but, crates typically have transitive dependencies, so you will likely have to bring in multiple libraries.

We'll discuss:

- How to put a crate in the Chromium source code tree
- How to make gn build rules for it
- How to audit its source code for sufficient safety.

45.1 Configuring the Cargo.toml file to add crates

Chromium has a single set of centrally-managed direct crate dependencies. These are managed through a single [Cargo.toml](#):

```
[dependencies]
bitflags = "1"
cfg-if = "1"
cxx = "1"
# lots more...
```

As with any other Cargo.toml, you can specify [more details about the dependencies](#) --- most commonly, you'll want to specify the features that you wish to enable in the crate.

When adding a crate to Chromium, you'll often need to provide some extra information in an additional file, `gnrt_config.toml`, which we'll meet next.

45.2 `gnrt_config.toml`'yi Yapılandırma

Alongside `Cargo.toml` is `gnrt_config.toml`. This contains Chromium-specific extensions to crate handling.

If you add a new crate, you should specify at least the `group`. This is one of:

```
# 'safe': The library satisfies the rule-of-2 and can be used in any process.
# 'sandbox': The library does not satisfy the rule-of-2 and must be used in
#             a sandboxed process such as the renderer or a utility process.
# 'test': The library is only used in tests.
```

For instance,

```
[crate.my-new-crate]
group = 'test' # only used in test code
```

Depending on the crate source code layout, you may also need to use this file to specify where its `LICENSE` file(s) can be found.

Later, we'll see some other things you will need to configure in this file to resolve problems.

45.3 Kasaların İndirilmesi

A tool called `gnrt` knows how to download crates and how to generate `BUILD.gn` rules.

To start, download the crate you want like this:

```
cd chromium/src
vpython3 tools/crates/run_gnrt.py -- vendor
```

Although the `gnrt` tool is part of the Chromium source code, by running this command you will be downloading and running its dependencies from `crates.io`. See [the earlier section](#) discussing this security decision.

This `vendor` command may download:

- Your crate
- Direct and transitive dependencies
- New versions of other crates, as required by `cargo` to resolve the complete set of crates required by Chromium.

Chromium maintains patches for some crates, kept in `//third_party/rust/chromium_crates_io/patches`. These will be reapplied automatically, but if patching fails you may need to take manual action.

45.4 `gn` İnşa Kurallarının Oluşturulması

Once you've downloaded the crate, generate the `BUILD.gn` files like this:

```
vpython3 tools/crates/run_gnrt.py -- gen
```

Now run `git status`. You should find:

- At least one new crate source code in `third_party/rust/chromium_crates_io/vendor`
- At least one new `BUILD.gn` in `third_party/rust/<crate name>/v<major semver version>`
- An appropriate `README.chromium`

The "major semver version" is a **Rust "semver" version number**.

Take a close look, especially at the things generated in `third_party/rust`.

Talk a little about semver --- and specifically the way that in Chromium it's to allow multiple incompatible versions of a crate, which is discouraged but sometimes necessary in the Cargo ecosystem.

45.5 Problemlerin Çözülmesi

If your build fails, it may be because of a `build.rs`: programs which do arbitrary things at build time. This is fundamentally at odds with the design of `gn` and `ninja` which aim for static, deterministic, build rules to maximize parallelism and repeatability of builds.

Some `build.rs` actions are automatically supported; others require action:

build script effect	Supported by our gn templates	Work required by
Checking rustc version to configure features on and off	Yes	None
Checking platform or CPU to configure features on and off	Yes	None
Generating code	Yes	Yes - specify in g
Building C/C++	No	Patch around it
Arbitrary other actions	No	Patch around it

Fortunately, most crates don't contain a build script, and fortunately, most build scripts only do the top two actions.

45.5.1 Kod Oluşturan İnşa Betikleri (Build Scripts)

If `ninja` complains about missing files, check the `build.rs` to see if it writes source code files.

If so, modify `gnrt_config.toml` to add `build-script-outputs` to the crate. If this is a transitive dependency, that is, one on which Chromium code should not directly depend, also add `allow-first-party-usage=false`. There are several examples already in that file:

```
[crate.unicode-linebreak]
allow-first-party-usage = false
build-script-outputs = ["tables.rs"]
```

Now rerun `gnrt.py -- gen` to regenerate `BUILD.gn` files to inform `ninja` that this particular output file is input to subsequent build steps.

45.5.2 C++ Kodunu İnşa Eden (Build) veya Keyfi Eylemler Gerçekleştiren İnşa Betikleri

Some crates use the `cc` crate to build and link C/C++ libraries. Other crates parse C/C++ using `bindgen` within their build scripts. These actions can't be supported in a Chromium context -- our gn, ninja and LLVM build system is very specific in expressing relationships between build actions.

So, your options are:

- Avoid these crates
- Apply a patch to the crate.

Patches should be kept in `third_party/rust/chromium_crates_io/patches/<crate>` - see for example the `patches against the cxx crate` - and will be applied automatically by gnrt each time it upgrades the crate.

45.6 Bir Kasaya Bağımlılık

Once you've added a third-party crate and generated build rules, depending on a crate is simple. Find your `rust_static_library` target, and add a dep on the `:lib` target within your crate.

Specifically,

```
      +-----+           +-----+
"//third_party/rust" | crate name | "/v" | major semver version | ":lib"
      +-----+           +-----+
```

For instance,

```
rust_static_library("my_rust_lib") {
  crate_root = "lib.rs"
  sources = [ "lib.rs" ]
  deps = [ "//third_party/rust/example_rust_crate/v1:lib" ]
}
```

45.7 Auditing Third Party Crates

Adding new libraries is subject to Chromium's standard `policies`, but of course also subject to security review. As you may be bringing in not just a single crate but also transitive dependencies, there may be a lot of code to review. On the other hand, safe Rust code can have limited negative side effects. How should you review it?

Over time Chromium aims to move to a process based around `cargo vet`.

Meanwhile, for each new crate addition, we are checking for the following:

- Understand why each crate is used. What's the relationship between crates? If the build system for each crate contains a `build.rs` or procedural macros, work out what they're for. Are they compatible with the way Chromium is normally built?
- Check each crate seems to be reasonably well maintained

- Use `cd third-party/rust/chromium_crates_io; cargo audit` to check for known vulnerabilities (first you'll need to `cargo install cargo-audit`, which ironically involves downloading lots of dependencies from the internet²)
- Ensure any unsafe code is good enough for the **Rule of Two**
- Check for any use of fs or net APIs
- Read all the code at a sufficient level to look for anything out of place that might have been maliciously inserted. (You can't realistically aim for 100% perfection here: there's often just too much code.)

These are just guidelines --- work with reviewers from `security@chromium.org` to work out the right way to become confident of the crate.

45.8 Checking Crates into Chromium Source Code

`git status` should reveal:

- Crate code in `//third_party/rust/chromium_crates_io`
- Metadata (`BUILD.gn` and `README.chromium`) in `//third_party/rust/<crate>/<version>`

Please also add an OWNERS file in the latter location.

You should land all this, along with your `Cargo.toml` and `gnrt_config.toml` changes, into the Chromium repo.

Important: you need to use `git add -f` because otherwise `.gitignore` files may result in some files being skipped.

As you do so, you might find presubmit checks fail because of non-inclusive language. This is because Rust crate data tends to include names of git branches, and many projects still use non-inclusive terminology there. So you may need to run:

```
infra/update_inclusive_language_presubmit_exempt_dirs.sh > infra/inclusive_language_pre
git add -p infra/inclusive_language_presubmit_exempt_dirs.txt # add whatever changes ar
```

45.9 Kasaları Güncel Tutmak

As the OWNER of any third party Chromium dependency, you are **expected to keep it up to date with any security fixes**. It is hoped that we will soon automate this for Rust crates, but for now, it's still your responsibility just as it is for any other third party dependency.

45.10 Alıştırma

Add `uwuify` to Chromium, turning off the crate's **default features**. Assume that the crate will be used in shipping Chromium, but won't be used to handle untrustworthy input.

(In the next exercise we'll use `uwuify` from Chromium, but feel free to skip ahead and do that now if you like. Or, you could create a new **rust_executable target** which uses `uwuify`).

Students will need to download lots of transitive dependencies.

The total crates needed are:

- `instant`,

- lock_api,
- parking_lot,
- parking_lot_core,
- redox_syscall,
- scopeguard,
- smallvec, and
- uwuify.

If students are downloading even more than that, they probably forgot to turn off the default features.

Thanks to [Daniel Liu](#) for this crate!

Bölüm 46

Bringing It Together --- Exercise

In this exercise, you're going to add a whole new Chromium feature, bringing together everything you already learned.

The Brief from Product Management

A community of pixies has been discovered living in a remote rainforest. It's important that we get Chromium for Pixies delivered to them as soon as possible.

The requirement is to translate all Chromium's UI strings into Pixie language.

There's not time to wait for proper translations, but fortunately pixie language is very close to English, and it turns out there's a Rust crate which does the translation.

In fact, you already **imported that crate in the previous exercise**.

(Obviously, real translations of Chrome require incredible care and diligence. Don't ship this!)

Steps

Modify `ResourceBundle::MaybeMangleLocalizedString` so that it unifies all strings before display. In this special build of Chromium, it should always do this irrespective of the setting of `mangle_localized_strings_`.

If you've done everything right across all these exercises, congratulations, you should have created Chrome for pixies!

- UTF16 vs UTF8. Students should be aware that Rust strings are always UTF8, and will probably decide that it's better to do the conversion on the C++ side using `base::UTF16ToUTF8` and back again.
- If students decide to do the conversion on the Rust side, they'll need to consider `String::from_utf16`, consider error handling, and consider which **CXX supported types can transfer a lot of u16s**.
- Students may design the C++/Rust boundary in several different ways, e.g. taking and returning strings by value, or taking a mutable reference to a string. If a mutable reference is used, CXX will likely tell the student that they need to use `Pin`. You may

need to explain what `Pin` does, and then explain why CXX needs it for mutable references to C++ data: the answer is that C++ data can't be moved around like Rust data, because it may contain self-referential pointers.

- The C++ target containing `ResourceBundle::MaybeMangleLocalizedString` will need to depend on a `rust_static_library` target. The student probably already did this.
- The `rust_static_library` target will need to depend on `//third_party/rust/uwuiify/v0_2:lib`.

Bölüm 47

Alıştırma Çözümleri

Solutions to the Chromium exercises can be found in [this series of CLs](#).

Kısım XI

Yalın Sistem (Bare Metal): Sabah

Bölüm 48

Welcome to Bare Metal Rust

This is a standalone one-day course about bare-metal Rust, aimed at people who are familiar with the basics of Rust (perhaps from completing the Comprehensive Rust course), and ideally also have some experience with bare-metal programming in some other language such as C.

Today we will talk about 'bare-metal' Rust: running Rust code without an OS underneath us. This will be divided into several parts:

- What is `no_std` Rust?
- Writing firmware for microcontrollers.
- Writing bootloader / kernel code for application processors.
- Some useful crates for bare-metal Rust development.

For the microcontroller part of the course we will use the **BBC micro:bit** v2 as an example. It's a **development board** based on the Nordic nRF52833 microcontroller with some LEDs and buttons, an I2C-connected accelerometer and compass, and an on-board SWD debugger.

To get started, install some tools we'll need later. On gLinux or Debian:

```
sudo apt install gdb-multiarch libudev-dev picocom pkg-config qemu-system-arm
rustup update
rustup target add aarch64-unknown-none thumbv7em-none-eabihf
rustup component add llvm-tools-preview
cargo install cargo-binutils
curl --proto '=https' --tlsv1.2 -LsSf https://github.com/probe-rs/probe-rs/releases/latest
```

And give users in the `plugdev` group access to the `micro:bit` programmer:

```
echo 'SUBSYSTEM=="hidraw", ATTRS{idVendor}=="0d28", MODE="0660", GROUP="logind", TAG+="uaccess"' |
sudo tee /etc/udev/rules.d/50-microbit.rules
sudo udevadm control --reload-rules
```

On MacOS:

```
xcode-select --install
brew install gdb picocom qemu
rustup update
rustup target add aarch64-unknown-none thumbv7em-none-eabihf
rustup component add llvm-tools-preview
```

```
cargo install cargo-binutils  
curl --proto '=https' --tlsv1.2 -LsSf https://github.com/probe-rs/probe-rs/releases/latest
```

Bölüm 49

no_std

core

alloc

std

- Slices, &str, CStr
- NonZeroU8...
- Option, Result
- Display, Debug, write!...
- Iterator
- Error
- panic!, assert_eq!...
- NonNull and all the usual pointer-related functions
- Future and async/await
- fence, AtomicBool, AtomicPtr, AtomicU32...
- Duration
- Box, Cow, Arc, Rc
- Vec, BinaryHeap, BtreeMap, LinkedList, VecDeque
- String, CString, format!
- HashMap
- Mutex, Condvar, Barrier, Once, RwLock, mpsc
- File and the rest of fs
- println!, Read, Write, Stdin, Stdout and the rest of io
- Path, OsString
- net
- Command, Child, ExitCode
- spawn, sleep and the rest of thread
- SystemTime, Instant
- HashMap depends on RNG.
- std re-exports the contents of both core and alloc.

49.1 A minimal no_std program

```
use core::panic::PanicInfo;

fn panic(_panic: &PanicInfo) -> ! {
    loop {}
}
```

- This will compile to an empty binary.
- std provides a panic handler; without it we must provide our own.
- It can also be provided by another crate, such as panic-halt.
- Depending on the target, you may need to compile with panic = "abort" to avoid an error about eh_personality.
- Note that there is no main or any other entry point; it's up to you to define your own entry point. This will typically involve a linker script and some assembly code to set things up ready for Rust code to run.

49.2 alloc

To use alloc you must implement a **global (heap) allocator**.

```
extern crate alloc;
extern crate panic_halt as _;

use alloc::string::ToString;
use alloc::vec::Vec;
use buddy_system_allocator::LockedHeap;

static HEAP_ALLOCATOR: LockedHeap<32> = LockedHeap::<32>::new();

static mut HEAP: [u8; 65536] = [0; 65536];

pub fn entry() {
    // SAFETY: `HEAP` is only used here and `entry` is only called once.
    unsafe {
        // Give the allocator some memory to allocate.
        HEAP_ALLOCATOR.lock().init(HEAP.as_mut_ptr() as usize, HEAP.len());
    }

    // Now we can do things that require heap allocation.
    let mut v = Vec::new();
    v.push("A string".to_string());
}
```

- buddy_system_allocator is a third-party crate implementing a basic buddy system allocator. Other crates are available, or you can write your own or hook into your existing allocator.
- The const parameter of LockedHeap is the max order of the allocator; i.e. in this case it can allocate regions of up to 2**32 bytes.

- If any crate in your dependency tree depends on `alloc` then you must have exactly one global allocator defined in your binary. Usually this is done in the top-level binary crate.
- `extern crate panic_halt as _;` is necessary to ensure that the `panic_halt` crate is linked in so we get its panic handler.
- This example will build but not run, as it doesn't have an entry point.

Bölüm 50

Mikrodenetleyiciler

The `cortex_m_rt` crate provides (among other things) a reset handler for Cortex M microcontrollers.

```
extern crate panic_halt as _;

mod interrupts;

use cortex_m_rt::entry;

fn main() -> ! {
    loop {}
}
```

Next we'll look at how to access peripherals, with increasing levels of abstraction.

- The `cortex_m_rt::entry` macro requires that the function have type `fn() -> !`, because returning to the reset handler doesn't make sense.
- Run the example with `cargo embed --bin minimal`

50.1 Ham MMIO

Most microcontrollers access peripherals via memory-mapped IO. Let's try turning on an LED on our micro:bit:

```
extern crate panic_halt as _;

mod interrupts;

use core::mem::size_of;
use cortex_m_rt::entry;

/// GPIO port 0 peripheral address
const GPIO_P0: usize = 0x5000_0000;
```



```

// GPIO peripheral offsets
const PIN_CNF: usize = 0x700;
const OUTSET: usize = 0x508;
const OUTCLR: usize = 0x50c;

// PIN_CNF fields
const DIR_OUTPUT: u32 = 0x1;
const INPUT_DISCONNECT: u32 = 0x1 << 1;
const PULL_DISABLED: u32 = 0x0 << 2;
const DRIVE_S0S1: u32 = 0x0 << 8;
const SENSE_DISABLED: u32 = 0x0 << 16;

fn main() -> ! {
    // Configure GPIO 0 pins 21 and 28 as push-pull outputs.
    let pin_cnf_21 = (GPIO_P0 + PIN_CNF + 21 * size_of::<u32>()) as *mut u32;
    let pin_cnf_28 = (GPIO_P0 + PIN_CNF + 28 * size_of::<u32>()) as *mut u32;
    // SAFETY: The pointers are to valid peripheral control registers, and no
    // aliases exist.
    unsafe {
        pin_cnf_21.write_volatile(
            DIR_OUTPUT
            | INPUT_DISCONNECT
            | PULL_DISABLED
            | DRIVE_S0S1
            | SENSE_DISABLED,
        );
        pin_cnf_28.write_volatile(
            DIR_OUTPUT
            | INPUT_DISCONNECT
            | PULL_DISABLED
            | DRIVE_S0S1
            | SENSE_DISABLED,
        );
    }

    // Set pin 28 low and pin 21 high to turn the LED on.
    let gpio0_outset = (GPIO_P0 + OUTSET) as *mut u32;
    let gpio0_outclr = (GPIO_P0 + OUTCLR) as *mut u32;
    // SAFETY: The pointers are to valid peripheral control registers, and no
    // aliases exist.
    unsafe {
        gpio0_outclr.write_volatile(1 << 28);
        gpio0_outset.write_volatile(1 << 21);
    }

    loop {}
}

```

- GPIO 0 pin 21 is connected to the first column of the LED matrix, and pin 28 to the first row.

Run the example with:

```
cargo embed --bin mmio
```

50.2 Peripheral Access Crates

`svd2rust` generates mostly-safe Rust wrappers for memory-mapped peripherals from `CMSIS-SVD` files.

```
extern crate panic_halt as _;

use cortex_m_rt::entry;
use nrf52833_pac::Peripherals;

fn main() -> ! {
    let p = Peripherals::take().unwrap();
    let gpio0 = p.P0;

    // Configure GPIO 0 pins 21 and 28 as push-pull outputs.
    gpio0.pin_cnf[21].write(|w| {
        w.dir().output();
        w.input().disconnect();
        w.pull().disabled();
        w.drive().s0s1();
        w.sense().disabled();
        w
    });
    gpio0.pin_cnf[28].write(|w| {
        w.dir().output();
        w.input().disconnect();
        w.pull().disabled();
        w.drive().s0s1();
        w.sense().disabled();
        w
    });

    // Set pin 28 low and pin 21 high to turn the LED on.
    gpio0.outclr.write(|w| w.pin28().clear());
    gpio0.outset.write(|w| w.pin21().set());

    loop {}
}
```

- SVD (System View Description) files are XML files typically provided by silicon vendors which describe the memory map of the device.
 - They are organised by peripheral, register, field and value, with names, descriptions, addresses and so on.
 - SVD files are often buggy and incomplete, so there are various projects which patch the mistakes, add missing details, and publish the generated crates.
- `cortex-m-rt` provides the vector table, among other things.

- If you `cargo install cargo-binutils` then you can run `cargo objdump --bin pac -- -d --no-show-raw-insn` to see the resulting binary.

Run the example with:

```
cargo embed --bin pac
```

50.3 HAL crates

HAL crates for many microcontrollers provide wrappers around various peripherals. These generally implement traits from `embedded-hal`.

```
extern crate panic_halt as _;

use cortex_m_rt::entry;
use embedded_hal::digital::OutputPin;
use nrf52833_hal::gpio::{p0, Level};
use nrf52833_hal::pac::Peripherals;

fn main() -> ! {
    let p = Peripherals::take().unwrap();

    // Create HAL wrapper for GPIO port 0.
    let gpio0 = p0::Parts::new(p.P0);

    // Configure GPIO 0 pins 21 and 28 as push-pull outputs.
    let mut col1 = gpio0.p0_28.into_push_pull_output(Level::High);
    let mut row1 = gpio0.p0_21.into_push_pull_output(Level::Low);

    // Set pin 28 low and pin 21 high to turn the LED on.
    col1.set_low().unwrap();
    row1.set_high().unwrap();

    loop {}
}
```

- `set_low` and `set_high` are methods on the `embedded_hal OutputPin` trait.
- HAL crates exist for many Cortex-M and RISC-V devices, including various STM32, GD32, nRF, NXP, MSP430, AVR and PIC microcontrollers.

Run the example with:

```
cargo embed --bin hal
```

50.4 Board support crates

Board support crates provide a further level of wrapping for a specific board for convenience.

```
extern crate panic_halt as _;
```

```

use cortex_m_rt::entry;
use embedded_hal::digital::OutputPin;
use microbit::Board;

fn main() -> ! {
    let mut board = Board::take().unwrap();

    board.display_pins.col1.set_low().unwrap();
    board.display_pins.row1.set_high().unwrap();

    loop {}
}

```

- In this case the board support crate is just providing more useful names, and a bit of initialisation.
- The crate may also include drivers for some on-board devices outside of the microcontroller itself.
 - microbit-v2 includes a simple driver for the LED matrix.

Run the example with:

```
cargo embed --bin board_support
```

50.5 The type state pattern

```

fn main() -> ! {
    let p = Peripherals::take().unwrap();
    let gpio0 = p0::Parts::new(p.P0);

    let pin: P0_01<Disconnected> = gpio0.p0_01;

    // let gpio0_01_again = gpio0.p0_01; // Error, moved.
    let mut pin_input: P0_01<Input<Floating>> = pin.into_floating_input();
    if pin_input.is_high().unwrap() {
        // ...
    }
    let mut pin_output: P0_01<Output<OpenDrain>> = pin_input
        .into_open_drain_output(OpenDrainConfig::Disconnect0Standard1, Level::Low);
    pin_output.set_high().unwrap();
    // pin_input.is_high(); // Error, moved.

    let _pin2: P0_02<Output<OpenDrain>> = gpio0
        .p0_02
        .into_open_drain_output(OpenDrainConfig::Disconnect0Standard1, Level::Low);
    let _pin3: P0_03<Output<PushPull>> =
        gpio0.p0_03.into_push_pull_output(Level::Low);

    loop {}
}

```

- Pins don't implement Copy or Clone, so only one instance of each can exist. Once a pin is moved out of the port struct nobody else can take it.

- Changing the configuration of a pin consumes the old pin instance, so you can't keep use the old instance afterwards.
- The type of a value indicates the state that it is in: e.g. in this case, the configuration state of a GPIO pin. This encodes the state machine into the type system, and ensures that you don't try to use a pin in a certain way without properly configuring it first. Illegal state transitions are caught at compile time.
- You can call `is_high` on an input pin and `set_high` on an output pin, but not vice-versa.
- Many HAL crates follow this pattern.

50.6 embedded-hal

The `embedded-hal` crate provides a number of traits covering common microcontroller peripherals:

- GPIO
- PWM
- Delay timers
- I2C and SPI buses and devices

Similar traits for byte streams (e.g. UARTs), CAN buses and RNGs and broken out into `embedded-io`, `embedded-can` and `rand_core` respectively.

Other crates then implement `drivers` in terms of these traits, e.g. an accelerometer driver might need an I2C or SPI device instance.

- The traits cover using the peripherals but not initialising or configuring them, as initialisation and configuration is usually highly platform-specific.
- There are implementations for many microcontrollers, as well as other platforms such as Linux on Raspberry Pi.
- `embedded-hal-async` provides async versions of the traits.
- `embedded-hal-nb` provides another approach to non-blocking I/O, based on the `nb` crate.

50.7 probe-rs ve cargo-embed

`probe-rs` is a handy toolset for embedded debugging, like OpenOCD but better integrated.

- SWD (Serial Wire Debug) and JTAG via CMSIS-DAP, ST-Link and J-Link probes
- GDB stub and Microsoft DAP (Debug Adapter Protocol) server
- Cargo integration

`cargo-embed` is a cargo subcommand to build and flash binaries, log RTT (Real Time Transfers) output and connect GDB. It's configured by an `Embed.toml` file in your project directory.

- `CMSIS-DAP` is an Arm standard protocol over USB for an in-circuit debugger to access the CoreSight Debug Access Port of various Arm Cortex processors. It's what the on-board debugger on the BBC micro:bit uses.
- ST-Link is a range of in-circuit debuggers from ST Microelectronics, J-Link is a range from SEGGER.
- The Debug Access Port is usually either a 5-pin JTAG interface or 2-pin Serial Wire Debug.
- `probe-rs` is a library which you can integrate into your own tools if you want to.

- The **Microsoft Debug Adapter Protocol** lets VSCode and other IDEs debug code running on any supported microcontroller.
- cargo-embed is a binary built using the probe-rs library.
- RTT (Real Time Transfers) is a mechanism to transfer data between the debug host and the target through a number of ringbuffers.

50.7.1 Hata Ayıklama

Embed.toml:

```
[default.general]
chip = "nrf52833_xxAA"
```

```
[debug.gdb]
enabled = true
```

In one terminal under `src/bare-metal/microcontrollers/examples/`:

```
cargo embed --bin board_support debug
```

In another terminal in the same directory:

On gLinux or Debian:

```
gdb-multiarch target/thumbv7em-none-eabihf/debug/board_support --eval-command="target r
```

On MacOS:

```
arm-none-eabi-gdb target/thumbv7em-none-eabihf/debug/board_support --eval-command="targ
```

In GDB, try running:

```
b src/bin/board_support.rs:29
b src/bin/board_support.rs:30
b src/bin/board_support.rs:32
c
c
c
```

50.8 Other projects

- **RTIC**
 - "Real-Time Interrupt-driven Concurrency".
 - Shared resource management, message passing, task scheduling, timer queue.
- **Embassy**
 - async executors with priorities, timers, networking, USB.
- **TockOS**
 - Security-focused RTOS with preemptive scheduling and Memory Protection Unit support.
- **Hubris**
 - Microkernel RTOS from Oxide Computer Company with memory protection, unprivileged drivers, IPC.
- **Bindings for FreeRTOS.**

Some platforms have std implementations, e.g. **esp-idf**.

- RTIC can be considered either an RTOS or a concurrency framework.
 - It doesn't include any HALs.
 - It uses the Cortex-M NVIC (Nested Virtual Interrupt Controller) for scheduling rather than a proper kernel.
 - Cortex-M only.
- Google uses TockOS on the Haven microcontroller for Titan security keys.
- FreeRTOS is mostly written in C, but there are Rust bindings for writing applications.

Bölüm 51

Alıştırmalar

We will read the direction from an I2C compass, and log the readings to a serial port. After looking at the exercises, you can look at the [solutions](#) provided.

51.1 Pusula

We will read the direction from an I2C compass, and log the readings to a serial port. If you have time, try displaying it on the LEDs somehow too, or use the buttons somehow.

Hints:

- Check the documentation for the `lsm303agr` and `microbit-v2` crates, as well as the [micro:bit hardware](#).
- The LSM303AGR Inertial Measurement Unit is connected to the internal I2C bus.
- TWI is another name for I2C, so the I2C master peripheral is called TWIM.
- The LSM303AGR driver needs something implementing the `embedded_hal::i2c::I2c` trait. The `microbit::hal::Twim` struct implements this.
- You have a `microbit::Board` struct with fields for the various pins and peripherals.
- You can also look at the [nRF52833 datasheet](#) if you want, but it shouldn't be necessary for this exercise.

Download the [exercise template](#) and look in the compass directory for the following files.

src/main.rs:

```
extern crate panic_halt as _;

use core::fmt::Write;
use cortex_m_rt::entry;
use microbit::{hal::{Delay, uarte::{Baudrate, Parity, Uarte}}, Board};

fn main() -> ! {
    let mut board = Board::take().unwrap();

    // Configure serial port.
```



```

let mut serial = Uarte::new(
    board.UARTE0,
    board.uart.into(),
    Parity::EXCLUDED,
    Baudrate::BAUD115200,
);

// Use the system timer as a delay provider.
let mut delay = Delay::new(board.SYST);

// Set up the I2C controller and Inertial Measurement Unit.
// TODO

writeln!(serial, "Ready.").unwrap();

loop {
    // Read compass data and log it to the serial port.
    // TODO
}
}

```

Cargo.toml (you shouldn't need to change this):

```

[workspace]

[package]
name = "compass"
version = "0.1.0"
edition = "2021"
publish = false

[dependencies]
cortex-m-rt = "0.7.5"
embedded-hal = "1.0.0"
lsm303agr = "1.1.0"
microbit-v2 = "0.15.1"
panic-halt = "1.0.0"

```

Embed.toml (you shouldn't need to change this):

```

[default.general]
chip = "nrf52833_xxAA"

[debug.gdb]
enabled = true

[debug.reset]
halt_afterwards = true

```

.cargo/config.toml (you shouldn't need to change this):

```

[build]
target = "thumbv7em-none-eabihf" # Cortex-M4F

```

```
[target.'cfg(all(target_arch = "arm", target_os = "none"))']  
rustflags = ["-C", "link-arg=-Tlink.x"]
```

See the serial output on Linux with:

```
picocom --baud 115200 --imap lfcrLf /dev/ttyACM0
```

Or on Mac OS something like (the device name may be slightly different):

```
picocom --baud 115200 --imap lfcrLf /dev/tty.usbmodem14502
```

Use Ctrl+A Ctrl+Q to quit picocom.

51.2 Bare Metal Rust Morning Exercise

Pusula

[\(back to exercise\)](#)

```
extern crate panic_halt as _;  
  
use core::fmt::Write;  
use cortex_m_rt::entry;  
use core::cmp::{max, min};  
use embedded_hal::digital::InputPin;  
use lsm303agr::{  
    AccelMode, AccelOutputDataRate, Lsm303agr, MagMode, MagOutputDataRate,  
};  
use microbit::display::blocking::Display;  
use microbit::hal::twim::Twim;  
use microbit::hal::uarte::{Baudrate, Parity, Uarte};  
use microbit::hal::{Delay, Timer};  
use microbit::pac::twim0::frequency::FREQUENCY_A;  
use microbit::Board;  
  
const COMPASS_SCALE: i32 = 30000;  
const ACCELEROMETER_SCALE: i32 = 700;  
  
fn main() -> ! {  
    let mut board = Board::take().unwrap();  
  
    // Configure serial port.  
    let mut serial = Uarte::new(  
        board.UARTE0,  
        board.uart.into(),  
        Parity::EXCLUDED,  
        Baudrate::BAUD115200,  
    );  
  
    // Use the system timer as a delay provider.  
    let mut delay = Delay::new(board.SYST);
```

```

// Set up the I2C controller and Inertial Measurement Unit.
writeln!(serial, "Setting up IMU...").unwrap();
let i2c = Twim::new(board.TWIM0, board.i2c_internal.into(), FREQUENCY_A::K100);
let mut imu = Lsm303agr::new_with_i2c(i2c);
imu.init().unwrap();
imu.set_mag_mode_and_odr(
    &mut delay,
    MagMode::HighResolution,
    MagOutputDataRate::Hz50,
)
.unwrap();
imu.set_accel_mode_and_odr(
    &mut delay,
    AccelMode::Normal,
    AccelOutputDataRate::Hz50,
)
.unwrap();
let mut imu = imu.into_mag_continuous().ok().unwrap();

// Set up display and timer.
let mut timer = Timer::new(board.TIMER0);
let mut display = Display::new(board.display_pins);

let mut mode = Mode::Compass;
let mut button_pressed = false;

writeln!(serial, "Ready.").unwrap();

loop {
    // Read compass data and log it to the serial port.
    while !(imu.mag_status().unwrap().xyz_new_data()
        && imu.accel_status().unwrap().xyz_new_data())
    {}
    let compass_reading = imu.magnetic_field().unwrap();
    let accelerometer_reading = imu.acceleration().unwrap();
    writeln!(
        serial,
        "{}, {}, {} \t {}, {}, {}",
        compass_reading.x_nt(),
        compass_reading.y_nt(),
        compass_reading.z_nt(),
        accelerometer_reading.x_mg(),
        accelerometer_reading.y_mg(),
        accelerometer_reading.z_mg(),
    )
    .unwrap();

    let mut image = [[0; 5]; 5];
    let (x, y) = match mode {
        Mode::Compass => (
            scale(-compass_reading.x_nt(), -COMPASS_SCALE, COMPASS_SCALE, 0, 4)

```

```

        as usize,
        scale(compass_reading.y_nt(), -COMPASS_SCALE, COMPASS_SCALE, 0, 4)
        as usize,
    ),
    Mode::Accelerometer => (
        scale(
            accelerometer_reading.x_mg(),
            -ACCELEROMETER_SCALE,
            ACCELEROMETER_SCALE,
            0,
            4,
        ) as usize,
        scale(
            -accelerometer_reading.y_mg(),
            -ACCELEROMETER_SCALE,
            ACCELEROMETER_SCALE,
            0,
            4,
        ) as usize,
    ),
};
image[y][x] = 255;
display.show(&mut timer, image, 100);

// If button A is pressed, switch to the next mode and briefly blink all LEDs
// on.
if board.buttons.button_a.is_low().unwrap() {
    if !button_pressed {
        mode = mode.next();
        display.show(&mut timer, [[255; 5]; 5], 200);
    }
    button_pressed = true;
} else {
    button_pressed = false;
}
}
}

enum Mode {
    Compass,
    Accelerometer,
}

impl Mode {
    fn next(self) -> Self {
        match self {
            Self::Compass => Self::Accelerometer,
            Self::Accelerometer => Self::Compass,
        }
    }
}
}

```

```
fn scale(value: i32, min_in: i32, max_in: i32, min_out: i32, max_out: i32) -> i32 {
    let range_in = max_in - min_in;
    let range_out = max_out - min_out;
    cap(min_out + range_out * (value - min_in) / range_in, min_out, max_out)
}

fn cap(value: i32, min_value: i32, max_value: i32) -> i32 {
    max(min_value, min(value, max_value))
}
```

Kısım XII

Yalın Sistem (Bare Metal): Öğleden Sonra

Bölüm 52

Application processors

So far we've talked about microcontrollers, such as the Arm Cortex-M series. Now let's try writing something for Cortex-A. For simplicity we'll just work with QEMU's aarch64 `'virt'` board.

- Broadly speaking, microcontrollers don't have an MMU or multiple levels of privilege (exception levels on Arm CPUs, rings on x86), while application processors do.
- QEMU supports emulating various different machines or board models for each architecture. The `'virt'` board doesn't correspond to any particular real hardware, but is designed purely for virtual machines.

52.1 Rust'a Hazırlanmak

Before we can start running Rust code, we need to do some initialisation.

```
.section .init.entry, "ax"
.global entry
entry:
    /*
     * Load and apply the memory management configuration, ready to
     * enable MMU and caches.
     */
    adrp x30, idmap
    msr ttbr0_el1, x30

    mov_i x30, .Lmairval
    msr mair_el1, x30

    mov_i x30, .Ltcrval
    /* Copy the supported PA range into TCR_EL1.IPS. */
    mrs x29, id_aa64mmfr0_el1
    bfi x30, x29, #32, #4

    msr tcr_el1, x30
```

```

mov_i x30, .Lsctlrval

/*
 * Ensure everything before this point has completed, then
 * invalidate any potentially stale local TLB entries before they
 * start being used.
 */
isb
tlbi vmalle1
ic iallu
dsb nsh
isb

/*
 * Configure sctlr_el1 to enable MMU and cache and don't proceed
 * until this has completed.
 */
msr sctlr_el1, x30
isb

/* Disable trapping floating point access in EL1. */
mrs x30, cpacr_el1
orr x30, x30, #(0x3 << 20)
msr cpacr_el1, x30
isb

/* Zero out the bss section. */
adr_l x29, bss_begin
adr_l x30, bss_end
0: cmp x29, x30
   b.hs 1f
   stp xzr, xzr, [x29], #16
   b 0b

1: /* Prepare the stack. */
   adr_l x30, boot_stack_end
   mov sp, x30

/* Set up exception vector. */
adr x30, vector_table_el1
msr vbar_el1, x30

/* Call into Rust code. */
bl main

/* Loop forever waiting for interrupts. */
2: wfi
   b 2b

```

- This is the same as it would be for C: initialising the processor state, zeroing the BSS, and setting up the stack pointer.

- The BSS (block starting symbol, for historical reasons) is the part of the object file which containing statically allocated variables which are initialised to zero. They are omitted from the image, to avoid wasting space on zeroes. The compiler assumes that the loader will take care of zeroing them.
- The BSS may already be zeroed, depending on how memory is initialised and the image is loaded, but we zero it to be sure.
- We need to enable the MMU and cache before reading or writing any memory. If we don't:
 - Unaligned accesses will fault. We build the Rust code for the aarch64-unknown-none target which sets `+strict-align` to prevent the compiler generating unaligned accesses, so it should be fine in this case, but this is not necessarily the case in general.
 - If it were running in a VM, this can lead to cache coherency issues. The problem is that the VM is accessing memory directly with the cache disabled, while the host has cacheable aliases to the same memory. Even if the host doesn't explicitly access the memory, speculative accesses can lead to cache fills, and then changes from one or the other will get lost when the cache is cleaned or the VM enables the cache. (Cache is keyed by physical address, not VA or IPA.)
- For simplicity, we just use a hardcoded pagetable (see `idmap.S`) which identity maps the first 1 GiB of address space for devices, the next 1 GiB for DRAM, and another 1 GiB higher up for more devices. This matches the memory layout that QEMU uses.
- We also set up the exception vector (`vbar_el1`), which we'll see more about later.
- All examples this afternoon assume we will be running at exception level 1 (EL1). If you need to run at a different exception level you'll need to modify `entry.S` accordingly.

52.2 Inline assembly

Sometimes we need to use assembly to do things that aren't possible with Rust code. For example, to make an HVC (hypervisor call) to tell the firmware to power off the system:

```
use core::arch::asm;
use core::panic::PanicInfo;

mod exceptions;

const PSCI_SYSTEM_OFF: u32 = 0x84000008;

// SAFETY: There is no other global function of this name.
extern "C" fn main(_x0: u64, _x1: u64, _x2: u64, _x3: u64) {
    // SAFETY: this only uses the declared registers and doesn't do anything
    // with memory.
    unsafe {
        asm!("hvc #0",
            inout("w0") PSCI_SYSTEM_OFF => _,
            inout("w1") 0 => _,
            inout("w2") 0 => _,
            inout("w3") 0 => _,
            inout("w4") 0 => _,
            inout("w5") 0 => _,
```

```

        inout("w6") 0 => _,
        inout("w7") 0 => _,
        options(nomem, nostack)
    );
}

loop {}
}

```

(If you actually want to do this, use the `smccc` crate which has wrappers for all these functions.)

- PSCI is the Arm Power State Coordination Interface, a standard set of functions to manage system and CPU power states, among other things. It is implemented by EL3 firmware and hypervisors on many systems.
- The `0 => _` syntax means initialise the register to 0 before running the inline assembly code, and ignore its contents afterwards. We need to use `inout` rather than `in` because the call could potentially clobber the contents of the registers.
- This main function needs to be `#[unsafe(no_mangle)]` and `extern "C"` because it is called from our entry point in `entry.S`.
- `_x0-_x3` are the values of registers `x0-x3`, which are conventionally used by the bootloader to pass things like a pointer to the device tree. According to the standard aarch64 calling convention (which is what `extern "C"` specifies to use), registers `x0-x7` are used for the first 8 arguments passed to a function, so `entry.S` doesn't need to do anything special except make sure it doesn't change these registers.
- Run the example in QEMU with `make qemu_psci` under `src/bare-metal/aps/examples`.

52.3 Volatile memory access for MMIO

- Use `pointer::read_volatile` and `pointer::write_volatile`.
- Never hold a reference.
- Use `&raw` to get fields of structs without creating an intermediate reference.
- Volatile access: read or write operations may have side-effects, so prevent the compiler or hardware from reordering, duplicating or eliding them.
 - Usually if you write and then read, e.g. via a mutable reference, the compiler may assume that the value read is the same as the value just written, and not bother actually reading memory.
- Some existing crates for volatile access to hardware do hold references, but this is unsound. Whenever a reference exist, the compiler may choose to dereference it.
- Use `&raw` to get struct field pointers from a pointer to the struct.
- For compatibility with old versions of Rust you can use the `addr_of!` macro instead.

52.4 Let's write a UART driver

The QEMU 'virt' machine has a `PL011` UART, so let's write a driver for that.

```

const FLAG_REGISTER_OFFSET: usize = 0x18;
const FR_BUSY: u8 = 1 << 3;
const FR_TXFF: u8 = 1 << 5;

/// Minimal driver for a PL011 UART.

```

```

pub struct Uart {
    base_address: *mut u8,
}

impl Uart {
    /// Constructs a new instance of the UART driver for a PL011 device at the
    /// given base address.
    ///
    /// # Safety
    ///
    /// The given base address must point to the 8 MMIO control registers of a
    /// PL011 device, which must be mapped into the address space of the process
    /// as device memory and not have any other aliases.
    pub unsafe fn new(base_address: *mut u8) -> Self {
        Self { base_address }
    }

    /// Writes a single byte to the UART.
    pub fn write_byte(&self, byte: u8) {
        // Wait until there is room in the TX buffer.
        while self.read_flag_register() & FR_TXFF != 0 {}

        // SAFETY: We know that the base address points to the control
        // registers of a PL011 device which is appropriately mapped.
        unsafe {
            // Write to the TX buffer.
            self.base_address.write_volatile(byte);
        }

        // Wait until the UART is no longer busy.
        while self.read_flag_register() & FR_BUSY != 0 {}
    }

    fn read_flag_register(&self) -> u8 {
        // SAFETY: We know that the base address points to the control
        // registers of a PL011 device which is appropriately mapped.
        unsafe { self.base_address.add(FLAGS_REGISTER_OFFSET).read_volatile() }
    }
}

```

- Note that `Uart::new` is unsafe while the other methods are safe. This is because as long as the caller of `Uart::new` guarantees that its safety requirements are met (i.e. that there is only ever one instance of the driver for a given UART, and nothing else aliasing its address space), then it is always safe to call `write_byte` later because we can assume the necessary preconditions.
- We could have done it the other way around (making `new` safe but `write_byte` unsafe), but that would be much less convenient to use as every place that calls `write_byte` would need to reason about the safety
- This is a common pattern for writing safe wrappers of unsafe code: moving the burden of proof for soundness from a large number of places to a smaller number of places.

52.4.1 More traits

We derived the Debug trait. It would be useful to implement a few more traits too.

```
use core::fmt::{self, Write};

impl Write for Uart {
    fn write_str(&mut self, s: &str) -> fmt::Result {
        for c in s.as_bytes() {
            self.write_byte(*c);
        }
        Ok(())
    }
}
```

```
// SAFETY: `Uart` just contains a pointer to device memory, which can be
// accessed from any context.
```

```
unsafe impl Send for Uart {}
```

- Implementing Write lets us use the write! and writeln! macros with our Uart type.
- Run the example in QEMU with make qemu_minimal under src/bare-metal/aps/examples.

52.5 A better UART driver

The PL011 actually has **a bunch more registers**, and adding offsets to construct pointers to access them is error-prone and hard to read. Plus, some of them are bit fields which would be nice to access in a structured way.

Offset	Register name	Width
0x00	DR	12
0x04	RSR	4
0x18	FR	9
0x20	ILPR	8
0x24	IBRD	16
0x28	FBRD	6
0x2c	LCR_H	8
0x30	CR	16
0x34	IFLS	6
0x38	IMSC	11
0x3c	RIS	11
0x40	MIS	11
0x44	ICR	11
0x48	DMACR	3

- There are also some ID registers which have been omitted for brevity.

52.5.1 Bitflags Kasasi

The **bitflags** crate is useful for working with bitflags.

```

use bitflags::bitflags;

bitflags! {
    /// Flags from the UART flag register.
    struct Flags: u16 {
        /// Clear to send.
        const CTS = 1 << 0;
        /// Data set ready.
        const DSR = 1 << 1;
        /// Data carrier detect.
        const DCD = 1 << 2;
        /// UART busy transmitting data.
        const BUSY = 1 << 3;
        /// Receive FIFO is empty.
        const RXFE = 1 << 4;
        /// Transmit FIFO is full.
        const TXFF = 1 << 5;
        /// Receive FIFO is full.
        const RXFF = 1 << 6;
        /// Transmit FIFO is empty.
        const TXFE = 1 << 7;
        /// Ring indicator.
        const RI = 1 << 8;
    }
}

```

- The `bitflags!` macro creates a newtype something like `Flags(u16)`, along with a bunch of method implementations to get and set flags.

52.5.2 Multiple registers

We can use a struct to represent the memory layout of the UART's registers.

```

struct Registers {
    dr: u16,
    _reserved0: [u8; 2],
    rsr: ReceiveStatus,
    _reserved1: [u8; 19],
    fr: Flags,
    _reserved2: [u8; 6],
    ilpr: u8,
    _reserved3: [u8; 3],
    ibrd: u16,
    _reserved4: [u8; 2],
    fbrd: u8,
    _reserved5: [u8; 3],
    lcr_h: u8,
    _reserved6: [u8; 3],
    cr: u16,
    _reserved7: [u8; 3],
    ifls: u8,
    _reserved8: [u8; 3],
}

```

```

    imsc: u16,
    _reserved9: [u8; 2],
    ris: u16,
    _reserved10: [u8; 2],
    mis: u16,
    _reserved11: [u8; 2],
    icr: u16,
    _reserved12: [u8; 2],
    dmacr: u8,
    _reserved13: [u8; 3],
}

```

- `#[repr(C)]` tells the compiler to lay the struct fields out in order, following the same rules as C. This is necessary for our struct to have a predictable layout, as default Rust representation allows the compiler to (among other things) reorder fields however it sees fit.

52.5.3 Sürücü

Now let's use the new Registers struct in our driver.

```

/// Driver for a PL011 UART.
pub struct Uart {
    registers: *mut Registers,
}

impl Uart {
    /// Constructs a new instance of the UART driver for a PL011 device at the
    /// given base address.
    ///
    /// # Safety
    ///
    /// The given base address must point to the 8 MMIO control registers of a
    /// PL011 device, which must be mapped into the address space of the process
    /// as device memory and not have any other aliases.
    pub unsafe fn new(base_address: *mut u32) -> Self {
        Self { registers: base_address as *mut Registers }
    }

    /// Writes a single byte to the UART.
    pub fn write_byte(&self, byte: u8) {
        // Wait until there is room in the TX buffer.
        while self.read_flag_register().contains(Flags::TXFF) {}

        // SAFETY: We know that self.registers points to the control registers
        // of a PL011 device which is appropriately mapped.
        unsafe {
            // Write to the TX buffer.
            (&raw mut (*self.registers).dr).write_volatile(byte.into());
        }

        // Wait until the UART is no longer busy.

```

```

    while self.read_flag_register().contains(Flags::BUSY) {}
}

/// Reads and returns a pending byte, or `None` if nothing has been
/// received.
pub fn read_byte(&self) -> Option<u8> {
    if self.read_flag_register().contains(Flags::RXFE) {
        None
    } else {
        // SAFETY: We know that self.registers points to the control
        // registers of a PL011 device which is appropriately mapped.
        let data = unsafe { (&raw const (*self.registers).dr).read_volatile() };
        // TODO: Check for error conditions in bits 8-11.
        Some(data as u8)
    }
}

fn read_flag_register(&self) -> Flags {
    // SAFETY: We know that self.registers points to the control registers
    // of a PL011 device which is appropriately mapped.
    unsafe { (&raw const (*self.registers).fr).read_volatile() }
}
}

```

- Note the use of `&raw const` / `&raw mut` to get pointers to individual fields without creating an intermediate reference, which would be unsound.

52.5.4 Using it

Let's write a small program using our driver to write to the serial console, and echo incoming bytes.

```

mod exceptions;
mod pl011;

use crate::pl011::Uart;
use core::fmt::Write;
use core::panic::PanicInfo;
use log::error;
use smccc::psci::system_off;
use smccc::Hvc;

/// Base address of the primary PL011 UART.
const PL011_BASE_ADDRESS: *mut u32 = 0x900_0000 as _;

// SAFETY: There is no other global function of this name.
extern "C" fn main(x0: u64, x1: u64, x2: u64, x3: u64) {
    // SAFETY: `PL011_BASE_ADDRESS` is the base address of a PL011 device, and
    // nothing else accesses that address range.
    let mut uart = unsafe { Uart::new(PL011_BASE_ADDRESS) };
}

```

```

writeln!(uart, "main({x0:#x}, {x1:#x}, {x2:#x}, {x3:#x})").unwrap();

loop {
    if let Some(byte) = uart.read_byte() {
        uart.write_byte(byte);
        match byte {
            b'\r' => {
                uart.write_byte(b'\n');
            }
            b'q' => break,
            _ => continue,
        }
    }
}

writeln!(uart, "\n\nBye!").unwrap();
system_off::<<Hvc>().unwrap();
}

```

- As in the [inline assembly](#) example, this main function is called from our entry point code in `entry.S`. See the speaker notes there for details.
- Run the example in QEMU with `make qemu` under `src/bare-metal/aps/examples`.

52.6 Kayıt Tutma (Logging)

It would be nice to be able to use the logging macros from the `log` crate. We can do this by implementing the `Log` trait.

```

use crate::pl011::Uart;
use core::fmt::Write;
use log::{LevelFilter, Log, Metadata, Record, SetLoggerError};
use spin::mutex::SpinMutex;

static LOGGER: Logger = Logger { uart: SpinMutex::new(None) };

struct Logger {
    uart: SpinMutex<Option<Uart>>,
}

impl Log for Logger {
    fn enabled(&self, _metadata: &Metadata) -> bool {
        true
    }

    fn log(&self, record: &Record) {
        writeln!(
            self.uart.lock().as_mut().unwrap(),
            "[{}] {}",
            record.level(),
            record.args()
        )
    }
}

```



```

        .unwrap();
    }

    fn flush(&self) {}
}

/// Initialises UART logger.
pub fn init(uart: Uart, max_level: LevelFilter) -> Result<(), SetLoggerError> {
    LOGGER.uart.lock().replace(uart);

    log::set_logger(&LOGGER)?;
    log::set_max_level(max_level);
    Ok(())
}

```

- The unwrap in log is safe because we initialise LOGGER before calling set_logger.

52.6.1 Using it

We need to initialise the logger before we use it.

```

mod exceptions;
mod logger;
mod pl011;

use crate::pl011::Uart;
use core::panic::PanicInfo;
use log::{error, info, LevelFilter};
use smccc::psci::system_off;
use smccc::Hvc;

/// Base address of the primary PL011 UART.
const PL011_BASE_ADDRESS: *mut u32 = 0x900_0000 as _;

// SAFETY: There is no other global function of this name.
extern "C" fn main(x0: u64, x1: u64, x2: u64, x3: u64) {
    // SAFETY: `PL011_BASE_ADDRESS` is the base address of a PL011 device, and
    // nothing else accesses that address range.
    let uart = unsafe { Uart::new(PL011_BASE_ADDRESS) };
    logger::init(uart, LevelFilter::Trace).unwrap();

    info!("main({x0:#x}, {x1:#x}, {x2:#x}, {x3:#x})");

    assert_eq!(x1, 42);

    system_off::<Hvc>().unwrap();
}

fn panic(info: &PanicInfo) -> ! {
    error!("{info}");
    system_off::<Hvc>().unwrap();
}

```

```

    loop {}
}

```

- Note that our panic handler can now log details of panics.
- Run the example in QEMU with `make qemu_logger` under `src/bare-metal/aps/examples`.

52.7 İstisnalar

AArch64 defines an exception vector table with 16 entries, for 4 types of exceptions (synchronous, IRQ, FIQ, SError) from 4 states (current EL with SP0, current EL with SPx, lower EL using AArch64, lower EL using AArch32). We implement this in assembly to save volatile registers to the stack before calling into Rust code:

```

use log::error;
use smccc::psci::system_off;
use smccc::Hvc;

// SAFETY: There is no other global function of this name.
extern "C" fn sync_exception_current(_elr: u64, _spsr: u64) {
    error!("sync_exception_current");
    system_off::<<Hvc>().unwrap();
}

// SAFETY: There is no other global function of this name.
extern "C" fn irq_current(_elr: u64, _spsr: u64) {
    error!("irq_current");
    system_off::<<Hvc>().unwrap();
}

// SAFETY: There is no other global function of this name.
extern "C" fn fiq_current(_elr: u64, _spsr: u64) {
    error!("fiq_current");
    system_off::<<Hvc>().unwrap();
}

// SAFETY: There is no other global function of this name.
extern "C" fn serr_current(_elr: u64, _spsr: u64) {
    error!("serr_current");
    system_off::<<Hvc>().unwrap();
}

// SAFETY: There is no other global function of this name.
extern "C" fn sync_lower(_elr: u64, _spsr: u64) {
    error!("sync_lower");
    system_off::<<Hvc>().unwrap();
}

// SAFETY: There is no other global function of this name.
extern "C" fn irq_lower(_elr: u64, _spsr: u64) {
    error!("irq_lower");
    system_off::<<Hvc>().unwrap();
}

```

```

}

// SAFETY: There is no other global function of this name.
extern "C" fn fiq_lower(_elr: u64, _spsr: u64) {
    error!("fiq_lower");
    system_off::(&).unwrap();
}

// SAFETY: There is no other global function of this name.
extern "C" fn serr_lower(_elr: u64, _spsr: u64) {
    error!("serr_lower");
    system_off::(&).unwrap();
}

```

- EL is exception level; all our examples this afternoon run in EL1.
- For simplicity we aren't distinguishing between SP0 and SPx for the current EL exceptions, or between AArch32 and AArch64 for the lower EL exceptions.
- For this example we just log the exception and power down, as we don't expect any of them to actually happen.
- We can think of exception handlers and our main execution context more or less like different threads. [Send and Sync](#) will control what we can share between them, just like with threads. For example, if we want to share some value between exception handlers and the rest of the program, and it's Send but not Sync, then we'll need to wrap it in something like a Mutex and put it in a static.

52.8 Other projects

- [oreboot](#)
 - "coreboot without the C".
 - Supports x86, aarch64 and RISC-V.
 - Relies on LinuxBoot rather than having many drivers itself.
- [Rust RaspberryPi OS tutorial](#)
 - Initialisation, UART driver, simple bootloader, JTAG, exception levels, exception handling, page tables.
 - Some dodginess around cache maintenance and initialisation in Rust, not necessarily a good example to copy for production code.
- [cargo-call-stack](#)
 - Static analysis to determine maximum stack usage.
- The RaspberryPi OS tutorial runs Rust code before the MMU and caches are enabled. This will read and write memory (e.g. the stack). However:
 - Without the MMU and cache, unaligned accesses will fault. It builds with `aarch64-unknown-none` which sets `+strict-align` to prevent the compiler generating unaligned accesses so it should be alright, but this is not necessarily the case in general.
 - If it were running in a VM, this can lead to cache coherency issues. The problem is that the VM is accessing memory directly with the cache disabled, while the host has cacheable aliases to the same memory. Even if the host doesn't explicitly access the memory, speculative accesses can lead to cache fills, and then changes from one or the other will get lost. Again this is alright in this particular case (running directly on the hardware with no hypervisor), but isn't a good pattern in general.

Bölüm 53

Kullanışlı kasalar (crates)

We'll go over a few crates which solve some common problems in bare-metal programming.

53.1 zerocopy

The `zerocopy` crate (from Fuchsia) provides traits and macros for safely converting between byte sequences and other types.

```
use zerocopy::{Immutable, IntoBytes};

enum RequestType {
    In = 0,
    Out = 1,
    Flush = 4,
}

struct VirtioBlockRequest {
    request_type: RequestType,
    reserved: u32,
    sector: u64,
}

fn main() {
    let request = VirtioBlockRequest {
        request_type: RequestType::Flush,
        sector: 42,
        ..Default::default()
    };

    assert_eq!(
        request.as_bytes(),
        &[4, 0, 0, 0, 0, 0, 0, 0, 0, 42, 0, 0, 0, 0, 0, 0]
    );
}
```

This is not suitable for MMIO (as it doesn't use volatile reads and writes), but can be useful for working with structures shared with hardware e.g. by DMA, or sent over some external interface.

- FromBytes can be implemented for types for which any byte pattern is valid, and so can safely be converted from an untrusted sequence of bytes.
- Attempting to derive FromBytes for these types would fail, because RequestType doesn't use all possible u32 values as discriminants, so not all byte patterns are valid.
- zerocopy::byteorder has types for byte-order aware numeric primitives.
- Run the example with cargo run under src/bare-metal/useful-crates/zerocopy-example/. (It won't run in the Playground because of the crate dependency.)

53.2 aarch64-paging

The `aarch64-paging` crate lets you create page tables according to the AArch64 Virtual Memory System Architecture.

```
use aarch64_paging::{
    idmap::IdMap,
    paging::{Attributes, MemoryRegion},
};

const ASID: usize = 1;
const ROOT_LEVEL: usize = 1;

// Create a new page table with identity mapping.
let mut idmap = IdMap::new(ASID, ROOT_LEVEL);
// Map a 2 MiB region of memory as read-only.
idmap.map_range(
    &MemoryRegion::new(0x80200000, 0x80400000),
    Attributes::NORMAL | Attributes::NON_GLOBAL | Attributes::READ_ONLY,
).unwrap();
// Set `TTBR0_EL1` to activate the page table.
idmap.activate();
```

- For now it only supports EL1, but support for other exception levels should be straightforward to add.
- This is used in Android for the `Protected VM Firmware`.
- There's no easy way to run this example, as it needs to run on real hardware or under QEMU.

53.3 buddy_system_allocator

`buddy_system_allocator` is a third-party crate implementing a basic buddy system allocator. It can be used both for `LockedHeap` implementing `GlobalAlloc` so you can use the standard `alloc` crate (as we saw [before](#)), or for allocating other address space. For example, we might want to allocate MMIO space for PCI BARs:

```
use buddy_system_allocator::FrameAllocator;
use core::alloc::Layout;
```

```
fn main() {
    let mut allocator = FrameAllocator::<32>::new();
    allocator.add_frame(0x200_0000, 0x400_0000);

    let layout = Layout::from_size_align(0x100, 0x100).unwrap();
    let bar = allocator
        .alloc_aligned(layout)
        .expect("Failed to allocate 0x100 byte MMIO region");
    println!("Allocated 0x100 byte MMIO region at {:#x}", bar);
}
```

- PCI BARs always have alignment equal to their size.
- Run the example with `cargo run` under `src/bare-metal/useful-crates/allocator-example/`. (It won't run in the Playground because of the crate dependency.)

53.4 tinyvec

Sometimes you want something which can be resized like a `Vec`, but without heap allocation. `tinyvec` provides this: a vector backed by an array or slice, which could be statically allocated or on the stack, which keeps track of how many elements are used and panics if you try to use more than are allocated.

```
use tinyvec::{array_vec, ArrayVec};
```

```
fn main() {
    let mut numbers: ArrayVec<u32; 5> = array_vec!(42, 66);
    println!("{numbers:?}");
    numbers.push(7);
    println!("{numbers:?}");
    numbers.remove(1);
    println!("{numbers:?}");
}
```

- `tinyvec` requires that the element type implement `Default` for initialisation.
- The Rust Playground includes `tinyvec`, so this example will run fine inline.

53.5 spin

`std::sync::Mutex` and the other synchronisation primitives from `std::sync` are not available in `core` or `alloc`. How can we manage synchronisation or interior mutability, such as for sharing state between different CPUs?

The `spin` crate provides spinlock-based equivalents of many of these primitives.

```
use spin::mutex::SpinMutex;

static counter: SpinMutex<u32> = SpinMutex::new(0);

fn main() {
    println!("count: {}", counter.lock());
    *counter.lock() += 2;
```

```
println!("count: {}", counter.lock());  
}
```

- Be careful to avoid deadlock if you take locks in interrupt handlers.
- `spin` also has a ticket lock mutex implementation; equivalents of `RwLock`, `Barrier` and `Once` from `std::sync`; and `Lazy` for lazy initialisation.
- The `once_cell` crate also has some useful types for late initialisation with a slightly different approach to `spin::once::Once`.
- The Rust Playground includes `spin`, so this example will run fine inline.

Bölüm 54

Android'de Yalın Sistem (Bare Metal)

To build a bare-metal Rust binary in AOSP, you need to use a `rust_ffi_static` Soong rule to build your Rust code, then a `cc_binary` with a linker script to produce the binary itself, and then a `raw_binary` to convert the ELF to a raw binary ready to be run.

```
rust_ffi_static {
    name: "libvmbase_example",
    defaults: ["vmbase_ffi_defaults"],
    crate_name: "vmbase_example",
    srcs: ["src/main.rs"],
    rustlibs: [
        "libvmbase",
    ],
}
```

```
cc_binary {
    name: "vmbase_example",
    defaults: ["vmbase_elf_defaults"],
    srcs: [
        "idmap.S",
    ],
    static_libs: [
        "libvmbase_example",
    ],
    linker_scripts: [
        "image.ld",
        ":vmbase_sections",
    ],
}
```

```
raw_binary {
    name: "vmbase_example_bin",
    stem: "vmbase_example.bin",
    src: ":vmbase_example",
}
```



```
    enabled: false,
    target: {
        android_arm64: {
            enabled: true,
        },
    },
}
```

54.1 vmbase

For VMs running under crosvm on aarch64, the **vmbase** library provides a linker script and useful defaults for the build rules, along with an entry point, UART console logging and more.

```
use vmbase::{main, println};
```

```
main!(main);
```

```
pub fn main(arg0: u64, arg1: u64, arg2: u64, arg3: u64) {
    println!("Hello world");
}
```

- The `main!` macro marks your main function, to be called from the `vmbase` entry point.
- The `vmbase` entry point handles console initialisation, and issues a `PSCI_SYSTEM_OFF` to shutdown the VM if your main function returns.

Bölüm 55

Alıştırmalar

We will write a driver for the PL031 real-time clock device.

After looking at the exercises, you can look at the [solutions](#) provided.

55.1 RTC driver

The QEMU aarch64 virt machine has a **PL031** real-time clock at 0x9010000. For this exercise, you should write a driver for it.

1. Use it to print the current time to the serial console. You can use the **chrono** crate for date/time formatting.
2. Use the match register and raw interrupt status to busy-wait until a given time, e.g. 3 seconds in the future. (Call **core::hint::spin_loop** inside the loop.)
3. *Extension if you have time:* Enable and handle the interrupt generated by the RTC match. You can use the driver provided in the **arm-gic** crate to configure the Arm Generic Interrupt Controller.
 - Use the RTC interrupt, which is wired to the GIC as `IntId::spi(2)`.
 - Once the interrupt is enabled, you can put the core to sleep via `arm_gic::wfi()`, which will cause the core to sleep until it receives an interrupt.

Download the [exercise template](#) and look in the `rtc` directory for the following files.

`src/main.rs`:

```
mod exceptions;
mod logger;
mod pl011;

use crate::pl011::Uart;
use arm_gic::gicv3::GicV3;
use core::panic::PanicInfo;
use log::{error, info, trace, LevelFilter};
use smccc::psci::system_off;
use smccc::Hvc;
```

```

/// Base addresses of the GICv3.
const GICD_BASE_ADDRESS: *mut u64 = 0x800_0000 as _;
const GICR_BASE_ADDRESS: *mut u64 = 0x80A_0000 as _;

/// Base address of the primary PL011 UART.
const PL011_BASE_ADDRESS: *mut u32 = 0x900_0000 as _;

// SAFETY: There is no other global function of this name.
extern "C" fn main(x0: u64, x1: u64, x2: u64, x3: u64) {
    // SAFETY: `PL011_BASE_ADDRESS` is the base address of a PL011 device, and
    // nothing else accesses that address range.
    let uart = unsafe { Uart::new(PL011_BASE_ADDRESS) };
    logger::init(uart, LevelFilter::Trace).unwrap();

    info!("main({:#x}, {:#x}, {:#x}, {:#x})", x0, x1, x2, x3);

    // SAFETY: `GICD_BASE_ADDRESS` and `GICR_BASE_ADDRESS` are the base
    // addresses of a GICv3 distributor and redistributor respectively, and
    // nothing else accesses those address ranges.
    let mut gic = unsafe { GicV3::new(GICD_BASE_ADDRESS, GICR_BASE_ADDRESS) };
    gic.setup();

    // TODO: Create instance of RTC driver and print current time.

    // TODO: Wait for 3 seconds.

    system_off::<Hvc>().unwrap();
}

fn panic(info: &PanicInfo) -> ! {
    error!("{info}");
    system_off::<Hvc>().unwrap();
    loop {}
}

```

src/exceptions.rs (you should only need to change this for the 3rd part of the exercise):

```

// Copyright 2023 Google LLC
//
// Licensed under the Apache License, Version 2.0 (the "License");
// you may not use this file except in compliance with the License.
// You may obtain a copy of the License at
//
//     http://www.apache.org/licenses/LICENSE-2.0
//
// Unless required by applicable law or agreed to in writing, software
// distributed under the License is distributed on an "AS IS" BASIS,
// WITHOUT WARRANTIES OR CONDITIONS OF ANY KIND, either express or implied.
// See the License for the specific language governing permissions and
// limitations under the License.

use arm_gic::gicv3::GicV3;

```

```

use log::{error, info, trace};
use smccc::psci::system_off;
use smccc::Hvc;

// SAFETY: There is no other global function of this name.
extern "C" fn sync_exception_current(_elr: u64, _spsr: u64) {
    error!("sync_exception_current");
    system_off::<<Hvc>().unwrap();
}

// SAFETY: There is no other global function of this name.
extern "C" fn irq_current(_elr: u64, _spsr: u64) {
    trace!("irq_current");
    let intid =
        GicV3::get_and_acknowledge_interrupt().expect("No pending interrupt");
    info!("IRQ {intid:?}");
}

// SAFETY: There is no other global function of this name.
extern "C" fn fiq_current(_elr: u64, _spsr: u64) {
    error!("fiq_current");
    system_off::<<Hvc>().unwrap();
}

// SAFETY: There is no other global function of this name.
extern "C" fn serr_current(_elr: u64, _spsr: u64) {
    error!("serr_current");
    system_off::<<Hvc>().unwrap();
}

// SAFETY: There is no other global function of this name.
extern "C" fn sync_lower(_elr: u64, _spsr: u64) {
    error!("sync_lower");
    system_off::<<Hvc>().unwrap();
}

// SAFETY: There is no other global function of this name.
extern "C" fn irq_lower(_elr: u64, _spsr: u64) {
    error!("irq_lower");
    system_off::<<Hvc>().unwrap();
}

// SAFETY: There is no other global function of this name.
extern "C" fn fiq_lower(_elr: u64, _spsr: u64) {
    error!("fiq_lower");
    system_off::<<Hvc>().unwrap();
}

// SAFETY: There is no other global function of this name.
extern "C" fn serr_lower(_elr: u64, _spsr: u64) {
    error!("serr_lower");
}

```

```

    system_off::<Hvc>().unwrap();
}
src/logger.rs (you shouldn't need to change this):
// Copyright 2023 Google LLC
//
// Licensed under the Apache License, Version 2.0 (the "License");
// you may not use this file except in compliance with the License.
// You may obtain a copy of the License at
//
//     http://www.apache.org/licenses/LICENSE-2.0
//
// Unless required by applicable law or agreed to in writing, software
// distributed under the License is distributed on an "AS IS" BASIS,
// WITHOUT WARRANTIES OR CONDITIONS OF ANY KIND, either express or implied.
// See the License for the specific language governing permissions and
// limitations under the License.

// ANCHOR: main
use crate::pl011::Uart;
use core::fmt::Write;
use log::{LevelFilter, Log, Metadata, Record, SetLoggerError};
use spin::mutex::SpinMutex;

static LOGGER: Logger = Logger { uart: SpinMutex::new(None) };

struct Logger {
    uart: SpinMutex<Option<Uart>>,
}

impl Log for Logger {
    fn enabled(&self, _metadata: &Metadata) -> bool {
        true
    }

    fn log(&self, record: &Record) {
        writeln!(
            self.uart.lock().as_mut().unwrap(),
            "[{}] {}",
            record.level(),
            record.args()
        )
        .unwrap();
    }

    fn flush(&self) {}
}

/// Initialises UART logger.
pub fn init(uart: Uart, max_level: LevelFilter) -> Result<(), SetLoggerError> {
    LOGGER.uart.lock().replace(uart);
}

```

```

    log::set_logger(&LOGGER)?;
    log::set_max_level(max_level);
    Ok(())
}

```

src/pl011.rs (you shouldn't need to change this):

```

// Copyright 2023 Google LLC
//
// Licensed under the Apache License, Version 2.0 (the "License");
// you may not use this file except in compliance with the License.
// You may obtain a copy of the License at
//
//      http://www.apache.org/licenses/LICENSE-2.0
//
// Unless required by applicable law or agreed to in writing, software
// distributed under the License is distributed on an "AS IS" BASIS,
// WITHOUT WARRANTIES OR CONDITIONS OF ANY KIND, either express or implied.
// See the License for the specific language governing permissions and
// limitations under the License.

```

```

use core::fmt::{self, Write};

```

```

// ANCHOR: Flags

```

```

use bitflags::bitflags;

```

```

bitflags! {
    /// Flags from the UART flag register.
    struct Flags: u16 {
        /// Clear to send.
        const CTS = 1 << 0;
        /// Data set ready.
        const DSR = 1 << 1;
        /// Data carrier detect.
        const DCD = 1 << 2;
        /// UART busy transmitting data.
        const BUSY = 1 << 3;
        /// Receive FIFO is empty.
        const RXFE = 1 << 4;
        /// Transmit FIFO is full.
        const TXFF = 1 << 5;
        /// Receive FIFO is full.
        const RXFF = 1 << 6;
        /// Transmit FIFO is empty.
        const TXFE = 1 << 7;
        /// Ring indicator.
        const RI = 1 << 8;
    }
}
// ANCHOR_END: Flags

```

```

bitflags! {
    /// Flags from the UART Receive Status Register / Error Clear Register.
    struct ReceiveStatus: u16 {
        /// Framing error.
        const FE = 1 << 0;
        /// Parity error.
        const PE = 1 << 1;
        /// Break error.
        const BE = 1 << 2;
        /// Overrun error.
        const OE = 1 << 3;
    }
}

// ANCHOR: Registers
struct Registers {
    dr: u16,
    _reserved0: [u8; 2],
    rsr: ReceiveStatus,
    _reserved1: [u8; 19],
    fr: Flags,
    _reserved2: [u8; 6],
    ilpr: u8,
    _reserved3: [u8; 3],
    ibrd: u16,
    _reserved4: [u8; 2],
    fbrd: u8,
    _reserved5: [u8; 3],
    lcr_h: u8,
    _reserved6: [u8; 3],
    cr: u16,
    _reserved7: [u8; 3],
    ifls: u8,
    _reserved8: [u8; 3],
    imsc: u16,
    _reserved9: [u8; 2],
    ris: u16,
    _reserved10: [u8; 2],
    mis: u16,
    _reserved11: [u8; 2],
    icr: u16,
    _reserved12: [u8; 2],
    dmacr: u8,
    _reserved13: [u8; 3],
}
// ANCHOR_END: Registers

// ANCHOR: Uart
/// Driver for a PL011 UART.
pub struct Uart {

```

```

    registers: *mut Registers,
}

impl Uart {
    /// Constructs a new instance of the UART driver for a PL011 device at the
    /// given base address.
    ///
    /// # Safety
    ///
    /// The given base address must point to the MMIO control registers of a
    /// PL011 device, which must be mapped into the address space of the process
    /// as device memory and not have any other aliases.
    pub unsafe fn new(base_address: *mut u32) -> Self {
        Self { registers: base_address as *mut Registers }
    }

    /// Writes a single byte to the UART.
    pub fn write_byte(&self, byte: u8) {
        // Wait until there is room in the TX buffer.
        while self.read_flag_register().contains(Flags::TXFF) {}

        // SAFETY: We know that self.registers points to the control registers
        // of a PL011 device which is appropriately mapped.
        unsafe {
            // Write to the TX buffer.
            (&raw mut (*self.registers).dr).write_volatile(byte.into());
        }

        // Wait until the UART is no longer busy.
        while self.read_flag_register().contains(Flags::BUSY) {}
    }

    /// Reads and returns a pending byte, or `None` if nothing has been
    /// received.
    pub fn read_byte(&self) -> Option<u8> {
        if self.read_flag_register().contains(Flags::RXFE) {
            None
        } else {
            // SAFETY: We know that self.registers points to the control
            // registers of a PL011 device which is appropriately mapped.
            let data = unsafe { (&raw const (*self.registers).dr).read_volatile() };
            // TODO: Check for error conditions in bits 8-11.
            Some(data as u8)
        }
    }

    fn read_flag_register(&self) -> Flags {
        // SAFETY: We know that self.registers points to the control registers
        // of a PL011 device which is appropriately mapped.
        unsafe { (&raw const (*self.registers).fr).read_volatile() }
    }
}

```



```

}
// ANCHOR_END: Uart

impl Write for Uart {
    fn write_str(&mut self, s: &str) -> fmt::Result {
        for c in s.as_bytes() {
            self.write_byte(*c);
        }
        Ok(())
    }
}

```

// Safe because it just contains a pointer to device memory, which can be
// accessed from any context.

```
unsafe impl Send for Uart {}
```

Cargo.toml (you shouldn't need to change this):

```
[workspace]
```

```
[package]
```

```
name = "rtc"
version = "0.1.0"
edition = "2021"
publish = false
```

```
[dependencies]
```

```
arm-gic = "0.1.2"
bitflags = "2.6.0"
chrono = { version = "0.4.38", default-features = false }
log = "0.4.22"
smccc = "0.1.1"
spin = "0.9.8"
```

```
[build-dependencies]
```

```
cc = "1.2.2"
```

build.rs (you shouldn't need to change this):

```

// Copyright 2023 Google LLC
//
// Licensed under the Apache License, Version 2.0 (the "License");
// you may not use this file except in compliance with the License.
// You may obtain a copy of the License at
//
//      http://www.apache.org/licenses/LICENSE-2.0
//
// Unless required by applicable law or agreed to in writing, software
// distributed under the License is distributed on an "AS IS" BASIS,
// WITHOUT WARRANTIES OR CONDITIONS OF ANY KIND, either express or implied.
// See the License for the specific language governing permissions and
// limitations under the License.

```

```

use cc::Build;
use std::env;

fn main() {
    env::set_var("CROSS_COMPILE", "aarch64-none-elf");
    env::set_var("CC", "clang");

    Build::new()
        .file("entry.S")
        .file("exceptions.S")
        .file("idmap.S")
        .compile("empty")
}

```

entry.S (you shouldn't need to change this):

```

/*
 * Copyright 2023 Google LLC
 *
 * Licensed under the Apache License, Version 2.0 (the "License");
 * you may not use this file except in compliance with the License.
 * You may obtain a copy of the License at
 *
 *     https://www.apache.org/licenses/LICENSE-2.0
 *
 * Unless required by applicable law or agreed to in writing, software
 * distributed under the License is distributed on an "AS IS" BASIS,
 * WITHOUT WARRANTIES OR CONDITIONS OF ANY KIND, either express or implied.
 * See the License for the specific language governing permissions and
 * limitations under the License.
 */

.macro adr_l, reg:req, sym:req
    adrp \reg, \sym
    add \reg, \reg, :lo12:\sym
.endm

.macro mov_i, reg:req, imm:req
    movz \reg, :abs_g3:\imm
    movk \reg, :abs_g2_nc:\imm
    movk \reg, :abs_g1_nc:\imm
    movk \reg, :abs_g0_nc:\imm
.endm

.set .L_MAIR_DEV_nGnRE, 0x04
.set .L_MAIR_MEM_WBWA, 0xff
.set .Lmairval, .L_MAIR_DEV_nGnRE | (.L_MAIR_MEM_WBWA << 8)

/* 4 KiB granule size for TTBR0_EL1. */
.set .L_TCR_TG0_4KB, 0x0 << 14
/* 4 KiB granule size for TTBR1_EL1. */
.set .L_TCR_TG1_4KB, 0x2 << 30

```

```

/* Disable translation table walk for TTBR1_EL1, generating a translation fault instead
.set .L_TCR_EPD1, 0x1 << 23
/* Translation table walks for TTBR0_EL1 are inner sharable. */
.set .L_TCR_SH_INNER, 0x3 << 12
/*
 * Translation table walks for TTBR0_EL1 are outer write-back read-allocate write-allocate
 * cacheable.
 */
.set .L_TCR_RGN_OWB, 0x1 << 10
/*
 * Translation table walks for TTBR0_EL1 are inner write-back read-allocate write-allocate
 * cacheable.
 */
.set .L_TCR_RGN_IWB, 0x1 << 8
/* Size offset for TTBR0_EL1 is 2**39 bytes (512 GiB). */
.set .L_TCR_T0SZ_512, 64 - 39
.set .L_tcrval, .L_TCR_TG0_4KB | .L_TCR_TG1_4KB | .L_TCR_EPD1 | .L_TCR_RGN_OWB
.set .L_tcrval, .L_tcrval | .L_TCR_RGN_IWB | .L_TCR_SH_INNER | .L_TCR_T0SZ_512

/* Stage 1 instruction access cacheability is unaffected. */
.set .L_SCTLR_ELx_I, 0x1 << 12
/* SP alignment fault if SP is not aligned to a 16 byte boundary. */
.set .L_SCTLR_ELx_SA, 0x1 << 3
/* Stage 1 data access cacheability is unaffected. */
.set .L_SCTLR_ELx_C, 0x1 << 2
/* EL0 and EL1 stage 1 MMU enabled. */
.set .L_SCTLR_ELx_M, 0x1 << 0
/* Privileged Access Never is unchanged on taking an exception to EL1. */
.set .L_SCTLR_EL1_SPAN, 0x1 << 23
/* SETEND instruction disabled at EL0 in aarch32 mode. */
.set .L_SCTLR_EL1_SED, 0x1 << 8
/* Various IT instructions are disabled at EL0 in aarch32 mode. */
.set .L_SCTLR_EL1_ITD, 0x1 << 7
.set .L_SCTLR_EL1_RES1, (0x1 << 11) | (0x1 << 20) | (0x1 << 22) | (0x1 << 28) | (0x1 << 30)
.set .L_sctlrval, .L_SCTLR_ELx_M | .L_SCTLR_ELx_C | .L_SCTLR_ELx_SA | .L_SCTLR_EL1_ITD | .L_SCTLR_EL1_SED
.set .L_sctlrval, .L_sctlrval | .L_SCTLR_ELx_I | .L_SCTLR_EL1_SPAN | .L_SCTLR_EL1_RES1

/**
 * This is a generic entry point for an image. It carries out the operations required to
 * load an image to be run. Specifically, it zeroes the bss section using registers x25 and x26,
 * prepares the stack, enables floating point, and sets up the exception vector. It prepares
 * for the Rust entry point, as these may contain boot parameters.
 */
.section .init.entry, "ax"
.global entry
entry:
    /* Load and apply the memory management configuration, ready to enable MMU and cache
    adrp x30, idmap
    msr ttbr0_el1, x30

    mov_i x30, .Lmairval

```

```

msr mair_el1, x30

mov_i x30, .Ltcrrval
/* Copy the supported PA range into TCR_EL1.IPS. */
mrs x29, id_aa64mmfr0_el1
bfi x30, x29, #32, #4

msr tcr_el1, x30

mov_i x30, .Lsctlrval

/*
 * Ensure everything before this point has completed, then invalidate any potential
 * local TLB entries before they start being used.
 */
isb
tlbi vmalle1
ic iallu
dsb nsh
isb

/*
 * Configure sctlr_el1 to enable MMU and cache and don't proceed until this has comp
 */
msr sctlr_el1, x30
isb

/* Disable trapping floating point access in EL1. */
mrs x30, cpacr_el1
orr x30, x30, #(0x3 << 20)
msr cpacr_el1, x30
isb

/* Zero out the bss section. */
adr_l x29, bss_begin
adr_l x30, bss_end
0: cmp x29, x30
   b.hs 1f
   stp xzr, xzr, [x29], #16
   b 0b

1: /* Prepare the stack. */
   adr_l x30, boot_stack_end
   mov sp, x30

/* Set up exception vector. */
adr x30, vector_table_el1
msr vbar_el1, x30

/* Call into Rust code. */
bl main

```

```

    /* Loop forever waiting for interrupts. */
2: wfi
   b 2b

exceptions.S (you shouldn't need to change this):

/*
 * Copyright 2023 Google LLC
 *
 * Licensed under the Apache License, Version 2.0 (the "License");
 * you may not use this file except in compliance with the License.
 * You may obtain a copy of the License at
 *
 *     https://www.apache.org/licenses/LICENSE-2.0
 *
 * Unless required by applicable law or agreed to in writing, software
 * distributed under the License is distributed on an "AS IS" BASIS,
 * WITHOUT WARRANTIES OR CONDITIONS OF ANY KIND, either express or implied.
 * See the License for the specific language governing permissions and
 * limitations under the License.
 */

/**
 * Saves the volatile registers onto the stack. This currently takes 14
 * instructions, so it can be used in exception handlers with 18 instructions
 * left.
 *
 * On return, x0 and x1 are initialised to elr_el2 and spsr_el2 respectively,
 * which can be used as the first and second arguments of a subsequent call.
 */
.macro save_volatile_to_stack
    /* Reserve stack space and save registers x0-x18, x29 & x30. */
    stp x0, x1, [sp, #-(8 * 24)]!
    stp x2, x3, [sp, #8 * 2]
    stp x4, x5, [sp, #8 * 4]
    stp x6, x7, [sp, #8 * 6]
    stp x8, x9, [sp, #8 * 8]
    stp x10, x11, [sp, #8 * 10]
    stp x12, x13, [sp, #8 * 12]
    stp x14, x15, [sp, #8 * 14]
    stp x16, x17, [sp, #8 * 16]
    str x18, [sp, #8 * 18]
    stp x29, x30, [sp, #8 * 20]

    /*
     * Save elr_el1 & spsr_el1. This such that we can take nested exception
     * and still be able to unwind.
     */
    mrs x0, elr_el1
    mrs x1, spsr_el1
    stp x0, x1, [sp, #8 * 22]

```

```

.endm

/**
 * Restores the volatile registers from the stack. This currently takes 14
 * instructions, so it can be used in exception handlers while still leaving 18
 * instructions left; if paired with save_volatile_to_stack, there are 4
 * instructions to spare.
 */
.macro restore_volatile_from_stack
    /* Restore registers x2-x18, x29 & x30. */
    ldp x2, x3, [sp, #8 * 2]
    ldp x4, x5, [sp, #8 * 4]
    ldp x6, x7, [sp, #8 * 6]
    ldp x8, x9, [sp, #8 * 8]
    ldp x10, x11, [sp, #8 * 10]
    ldp x12, x13, [sp, #8 * 12]
    ldp x14, x15, [sp, #8 * 14]
    ldp x16, x17, [sp, #8 * 16]
    ldr x18, [sp, #8 * 18]
    ldp x29, x30, [sp, #8 * 20]

    /* Restore registers elr_el1 & spsr_el1, using x0 & x1 as scratch. */
    ldp x0, x1, [sp, #8 * 22]
    msr elr_el1, x0
    msr spsr_el1, x1

    /* Restore x0 & x1, and release stack space. */
    ldp x0, x1, [sp], #8 * 24
.endm

/**
 * This is a generic handler for exceptions taken at the current EL while using
 * SP0. It behaves similarly to the SPx case by first switching to SPx, doing
 * the work, then switching back to SP0 before returning.
 *
 * Switching to SPx and calling the Rust handler takes 16 instructions. To
 * restore and return we need an additional 16 instructions, so we can implement
 * the whole handler within the allotted 32 instructions.
 */
.macro current_exception_sp0 handler:req
    msr spsel, #1
    save_volatile_to_stack
    bl \handler
    restore_volatile_from_stack
    msr spsel, #0
    eret
.endm

/**
 * This is a generic handler for exceptions taken at the current EL while using
 * SPx. It saves volatile registers, calls the Rust handler, restores volatile

```

```

* registers, then returns.
*
* This also works for exceptions taken from EL0, if we don't care about
* non-volatile registers.
*
* Saving state and jumping to the Rust handler takes 15 instructions, and
* restoring and returning also takes 15 instructions, so we can fit the whole
* handler in 30 instructions, under the limit of 32.
*/
.macro current_exception_spx handler:req
    save_volatile_to_stack
    bl \handler
    restore_volatile_from_stack
    eret
.endm

.section .text.vector_table_el1, "ax"
.global vector_table_el1
.balign 0x800
vector_table_el1:
sync_cur_sp0:
    current_exception_sp0 sync_exception_current

.balign 0x80
irq_cur_sp0:
    current_exception_sp0 irq_current

.balign 0x80
fiq_cur_sp0:
    current_exception_sp0 fiq_current

.balign 0x80
serr_cur_sp0:
    current_exception_sp0 serr_current

.balign 0x80
sync_cur_spx:
    current_exception_spx sync_exception_current

.balign 0x80
irq_cur_spx:
    current_exception_spx irq_current

.balign 0x80
fiq_cur_spx:
    current_exception_spx fiq_current

.balign 0x80
serr_cur_spx:
    current_exception_spx serr_current

```

```
.balign 0x80
sync_lower_64:
    current_exception_spx sync_lower
```

```
.balign 0x80
irq_lower_64:
    current_exception_spx irq_lower
```

```
.balign 0x80
fiq_lower_64:
    current_exception_spx fiq_lower
```

```
.balign 0x80
serr_lower_64:
    current_exception_spx serr_lower
```

```
.balign 0x80
sync_lower_32:
    current_exception_spx sync_lower
```

```
.balign 0x80
irq_lower_32:
    current_exception_spx irq_lower
```

```
.balign 0x80
fiq_lower_32:
    current_exception_spx fiq_lower
```

```
.balign 0x80
serr_lower_32:
    current_exception_spx serr_lower
```

idmap.S (you shouldn't need to change this):

```
/*
 * Copyright 2023 Google LLC
 *
 * Licensed under the Apache License, Version 2.0 (the "License");
 * you may not use this file except in compliance with the License.
 * You may obtain a copy of the License at
 *
 *     https://www.apache.org/licenses/LICENSE-2.0
 *
 * Unless required by applicable law or agreed to in writing, software
 * distributed under the License is distributed on an "AS IS" BASIS,
 * WITHOUT WARRANTIES OR CONDITIONS OF ANY KIND, either express or implied.
 * See the License for the specific language governing permissions and
 * limitations under the License.
 */
```

```
.set .L_TT_TYPE_BLOCK, 0x1
.set .L_TT_TYPE_PAGE, 0x3
```



```

.set .L_TT_TYPE_TABLE, 0x3

/* Access flag. */
.set .L_TT_AF, 0x1 << 10
/* Not global. */
.set .L_TT_NG, 0x1 << 11
.set .L_TT_XN, 0x3 << 53

.set .L_TT_MT_DEV, 0x0 << 2 // MAIR #0 (DEV_nGnRE)
.set .L_TT_MT_MEM, (0x1 << 2) | (0x3 << 8) // MAIR #1 (MEM_WBWA), inner shareable

.set .L_BLOCK_DEV, .L_TT_TYPE_BLOCK | .L_TT_MT_DEV | .L_TT_AF | .L_TT_XN
.set .L_BLOCK_MEM, .L_TT_TYPE_BLOCK | .L_TT_MT_MEM | .L_TT_AF | .L_TT_NG

.section ".rodata.idmap", "a", %progbits
.global idmap
.align 12
idmap:
/* level 1 */
.quad .L_BLOCK_DEV | 0x0 // 1 GiB of device mappings
.quad .L_BLOCK_MEM | 0x40000000 // 1 GiB of DRAM
.fill 254, 8, 0x0 // 254 GiB of unmapped VA space
.quad .L_BLOCK_DEV | 0x40000000 // 1 GiB of device mappings
.fill 255, 8, 0x0 // 255 GiB of remaining VA space

image.ld (you shouldn't need to change this):
/*
* Copyright 2023 Google LLC
*
* Licensed under the Apache License, Version 2.0 (the "License");
* you may not use this file except in compliance with the License.
* You may obtain a copy of the License at
*
* https://www.apache.org/licenses/LICENSE-2.0
*
* Unless required by applicable law or agreed to in writing, software
* distributed under the License is distributed on an "AS IS" BASIS,
* WITHOUT WARRANTIES OR CONDITIONS OF ANY KIND, either express or implied.
* See the License for the specific language governing permissions and
* limitations under the License.
*/

/*
* Code will start running at this symbol which is placed at the start of the
* image.
*/
ENTRY(entry)

MEMORY
{
    image : ORIGIN = 0x40080000, LENGTH = 2M
}

```

```

}

SECTIONS
{
    /*
    * Collect together the code.
    */
    .init : ALIGN(4096) {
        text_begin = .;
        *(.init.entry)
        *(.init.*)
    } >image
    .text : {
        *(.text.*)
    } >image
    text_end = .;

    /*
    * Collect together read-only data.
    */
    .rodata : ALIGN(4096) {
        rodata_begin = .;
        *(.rodata.*)
    } >image
    .got : {
        *(.got)
    } >image
    rodata_end = .;

    /*
    * Collect together the read-write data including .bss at the end which
    * will be zero'd by the entry code.
    */
    .data : ALIGN(4096) {
        data_begin = .;
        *(.data.*)
        /*
        * The entry point code assumes that .data is a multiple of 32
        * bytes long.
        */
        . = ALIGN(32);
        data_end = .;
    } >image

    /* Everything beyond this point will not be included in the binary. */
    bin_end = .;

    /* The entry point code assumes that .bss is 16-byte aligned. */
    .bss : ALIGN(16) {
        bss_begin = .;
        *(.bss.*)
    }
}

```

```

        *(COMMON)
        . = ALIGN(16);
        bss_end = .;
    } >image

    .stack (NOLOAD) : ALIGN(4096) {
        boot_stack_begin = .;
        . += 40 * 4096;
        . = ALIGN(4096);
        boot_stack_end = .;
    } >image

    . = ALIGN(4K);
    PROVIDE(dma_region = .);

    /*
     * Remove unused sections from the image.
     */
    /DISCARD/ : {
        /* The image loads itself so doesn't need these sections. */
        *(.gnu.hash)
        *(.hash)
        *(.interp)
        *(.eh_frame_hdr)
        *(.eh_frame)
        *(.note.gnu.build-id)
    }
}

```

Makefile (you shouldn't need to change this):

```

# Copyright 2023 Google LLC
#
# Licensed under the Apache License, Version 2.0 (the "License");
# you may not use this file except in compliance with the License.
# You may obtain a copy of the License at
#
#     http://www.apache.org/licenses/LICENSE-2.0
#
# Unless required by applicable law or agreed to in writing, software
# distributed under the License is distributed on an "AS IS" BASIS,
# WITHOUT WARRANTIES OR CONDITIONS OF ANY KIND, either express or implied.
# See the License for the specific language governing permissions and
# limitations under the License.

.PHONY: build qemu_minimal qemu qemu_logger

all: rtc.bin

build:
    cargo build

```

```

rtc.bin: build
    cargo objcopy -- -O binary $@

qemu: rtc.bin
    qemu-system-aarch64 -machine virt,gic-version=3 -cpu max -serial mon:stdio -display

clean:
    cargo clean
    rm -f *.bin

```

.cargo/config.toml (you shouldn't need to change this):

```

[build]
target = "aarch64-unknown-none"
rustflags = ["-C", "link-arg=-Timage.ld"]

```

Run the code in QEMU with `make qemu`.

55.2 Yalın (Bare) Metal Rust Öğleden Sonra

RTC driver

[\(back to exercise\)](#)

main.rs:

```

mod exceptions;
mod logger;
mod pl011;
mod pl031;

use crate::pl031::Rtc;
use arm_gic::gicv3::{IntId, Trigger};
use arm_gic::{irq_enable, wfi};
use chrono::{TimeZone, Utc};
use core::hint::spin_loop;
use crate::pl011::Uart;
use arm_gic::gicv3::GicV3;
use core::panic::PanicInfo;
use log::{error, info, trace, LevelFilter};
use smccc::psci::system_off;
use smccc::Hvc;

/// Base addresses of the GICv3.
const GICD_BASE_ADDRESS: *mut u64 = 0x800_0000 as _;
const GICR_BASE_ADDRESS: *mut u64 = 0x80A_0000 as _;

/// Base address of the primary PL011 UART.
const PL011_BASE_ADDRESS: *mut u32 = 0x900_0000 as _;

/// Base address of the PL031 RTC.

```

```

const PL031_BASE_ADDRESS: *mut u32 = 0x901_0000 as _;
/// The IRQ used by the PL031 RTC.
const PL031_IRQ: IntId = IntId::spi(2);

// SAFETY: There is no other global function of this name.
extern "C" fn main(x0: u64, x1: u64, x2: u64, x3: u64) {
    // SAFETY: `PL011_BASE_ADDRESS` is the base address of a PL011 device, and
    // nothing else accesses that address range.
    let uart = unsafe { Uart::new(PL011_BASE_ADDRESS) };
    logger::init(uart, LevelFilter::Trace).unwrap();

    info!("main({:#x}, {:#x}, {:#x}, {:#x})", x0, x1, x2, x3);

    // SAFETY: `GICD_BASE_ADDRESS` and `GICR_BASE_ADDRESS` are the base
    // addresses of a GICv3 distributor and redistributor respectively, and
    // nothing else accesses those address ranges.
    let mut gic = unsafe { GicV3::new(GICD_BASE_ADDRESS, GICR_BASE_ADDRESS) };
    gic.setup();

    // SAFETY: `PL031_BASE_ADDRESS` is the base address of a PL031 device, and
    // nothing else accesses that address range.
    let mut rtc = unsafe { Rtc::new(PL031_BASE_ADDRESS) };
    let timestamp = rtc.read();
    let time = Utc.timestamp_opt(timestamp.into(), 0).unwrap();
    info!("RTC: {time}");

    GicV3::set_priority_mask(0xff);
    gic.set_interrupt_priority(PL031_IRQ, 0x80);
    gic.set_trigger(PL031_IRQ, Trigger::Level);
    irq_enable();
    gic.enable_interrupt(PL031_IRQ, true);

    // Wait for 3 seconds, without interrupts.
    let target = timestamp + 3;
    rtc.set_match(target);
    info!("Waiting for {}", Utc.timestamp_opt(target.into(), 0).unwrap());
    trace!(
        "matched={}, interrupt_pending={}",
        rtc.matched(),
        rtc.interrupt_pending()
    );
    while !rtc.matched() {
        spin_loop();
    }
    trace!(
        "matched={}, interrupt_pending={}",
        rtc.matched(),
        rtc.interrupt_pending()
    );
    info!("Finished waiting");
}

```

```

// Wait another 3 seconds for an interrupt.
let target = timestamp + 6;
info!("Waiting for {}", Utc.timestamp_opt(target.into(), 0).unwrap());
rtc.set_match(target);
rtc.clear_interrupt();
rtc.enable_interrupt(true);
trace!(
    "matched={}, interrupt_pending={}",
    rtc.matched(),
    rtc.interrupt_pending()
);
while !rtc.interrupt_pending() {
    wfi();
}
trace!(
    "matched={}, interrupt_pending={}",
    rtc.matched(),
    rtc.interrupt_pending()
);
info!("Finished waiting");

system_off::<Hvc>().unwrap();
}

```

```

fn panic(info: &PanicInfo) -> ! {
    error!("{info}");
    system_off::<Hvc>().unwrap();
    loop {}
}

```

pl031.rs:

```

struct Registers {
    // Data register
    dr: u32,
    // Match register
    mr: u32,
    // Load register
    lr: u32,
    // Control register
    cr: u8,
    _reserved0: [u8; 3],
    // Interrupt Mask Set or Clear register
    imsc: u8,
    _reserved1: [u8; 3],
    // Raw Interrupt Status
    ris: u8,
    _reserved2: [u8; 3],
    // Masked Interrupt Status
    mis: u8,
    _reserved3: [u8; 3],
    // Interrupt Clear Register

```

```

    icr: u8,
    _reserved4: [u8; 3],
}

/// Driver for a PL031 real-time clock.
pub struct Rtc {
    registers: *mut Registers,
}

impl Rtc {
    /// Constructs a new instance of the RTC driver for a PL031 device at the
    /// given base address.
    ///
    /// # Safety
    ///
    /// The given base address must point to the MMIO control registers of a
    /// PL031 device, which must be mapped into the address space of the process
    /// as device memory and not have any other aliases.
    pub unsafe fn new(base_address: *mut u32) -> Self {
        Self { registers: base_address as *mut Registers }
    }

    /// Reads the current RTC value.
    pub fn read(&self) -> u32 {
        // SAFETY: We know that self.registers points to the control registers
        // of a PL031 device which is appropriately mapped.
        unsafe { (&raw const (*self.registers).dr).read_volatile() }
    }

    /// Writes a match value. When the RTC value matches this then an interrupt
    /// will be generated (if it is enabled).
    pub fn set_match(&mut self, value: u32) {
        // SAFETY: We know that self.registers points to the control registers
        // of a PL031 device which is appropriately mapped.
        unsafe { (&raw mut (*self.registers).mr).write_volatile(value) }
    }

    /// Returns whether the match register matches the RTC value, whether or not
    /// the interrupt is enabled.
    pub fn matched(&self) -> bool {
        // SAFETY: We know that self.registers points to the control registers
        // of a PL031 device which is appropriately mapped.
        let ris = unsafe { (&raw const (*self.registers).ris).read_volatile() };
        (ris & 0x01) != 0
    }

    /// Returns whether there is currently an interrupt pending.
    ///
    /// This should be true if and only if `matched` returns true and the
    /// interrupt is masked.
    pub fn interrupt_pending(&self) -> bool {

```

```

    // SAFETY: We know that self.registers points to the control registers
    // of a PL031 device which is appropriately mapped.
    let ris = unsafe { (&raw const (*self.registers).mis).read_volatile() };
    (ris & 0x01) != 0
}

/// Sets or clears the interrupt mask.
///
/// When the mask is true the interrupt is enabled; when it is false the
/// interrupt is disabled.
pub fn enable_interrupt(&mut self, mask: bool) {
    let imsc = if mask { 0x01 } else { 0x00 };
    // SAFETY: We know that self.registers points to the control registers
    // of a PL031 device which is appropriately mapped.
    unsafe { (&raw mut (*self.registers).imsc).write_volatile(imsc) }
}

/// Clears a pending interrupt, if any.
pub fn clear_interrupt(&mut self) {
    // SAFETY: We know that self.registers points to the control registers
    // of a PL031 device which is appropriately mapped.
    unsafe { (&raw mut (*self.registers).icr).write_volatile(0x01) }
}
}

// SAFETY: `Rtc` just contains a pointer to device memory, which can be
// accessed from any context.
unsafe impl Send for Rtc {}

```

Kısım XIII

Eřzamanlılık: Sabah

Bölüm 56

Welcome to Concurrency in Rust

Rust has full support for concurrency using OS threads with mutexes and channels.

The Rust type system plays an important role in making many concurrency bugs compile time bugs. This is often referred to as *fearless concurrency* since you can rely on the compiler to ensure correctness at runtime.

Zamanlama (Schedule)

Bu oturum 10 dakikalık aralar dahil yaklaşık 3 saat 20 dakika sürmelidir. İçeriği:

Bölüm	Süre
İş Parçacıkları (Threads)	30 dakika
Kanallar	20 dakika
Send ve Sync	15 dakika
Paylaşımlı Durum (State)	30 dakika
Alıştırmalar	1 saat 10 dakika

- Rust lets us access OS concurrency toolkit: threads, sync. primitives, etc.
- The type system gives us safety for concurrency without any special features.
- The same tools that help with "concurrent" access in a single thread (e.g., a called function that might mutate an argument or save references to it to read later) save us from multi-threading issues.

Bölüm 57

İş Parçacıkları (Threads)

Bu bölüm yaklaşık 30 dakika sürmelidir. İçeriği:

Slayt	Süre
Temel İş Parçacıkları (Plain Threads)	15 dakika
Kapsamlı İş Parçacıkları (Threads)	15 dakika

57.1 Temel İş Parçacıkları (Plain Threads)

Rust threads work similarly to threads in other languages:

```
use std::thread;
use std::time::Duration;

fn main() {
    thread::spawn(|| {
        for i in 0..10 {
            println!("Count in thread: {i}!");
            thread::sleep(Duration::from_millis(5));
        }
    });

    for i in 0..5 {
        println!("Main thread: {i}");
        thread::sleep(Duration::from_millis(5));
    }
}
```

- Spawning new threads does not automatically delay program termination at the end of `main`.
- Thread panics are independent of each other.
 - Panics can carry a payload, which can be unpacked with `Any::downcast_ref`.
- Run the example.

- 5ms timing is loose enough that main and spawned threads stay mostly in lockstep.
- Notice that the program ends before the spawned thread reaches 10!
- This is because main ends the program and spawned threads do not make it persist.
 - * Compare to pthreads/C++ `std::thread/boost::thread` if desired.
- How do we wait around for the spawned thread to complete?
- `thread::spawn` returns a `JoinHandle`. Look at the docs.
 - `JoinHandle` has a `.join()` method that blocks.
- Use `let handle = thread::spawn(...)` and later `handle.join()` to wait for the thread to finish and have the program count all the way to 10.
- Now what if we want to return a value?
- Look at docs again:
 - `thread::spawn`'s closure returns `T`
 - `JoinHandle.join()` returns `thread::Result<T>`
- Use the `Result` return value from `handle.join()` to get access to the returned value.
- Ok, what about the other case?
 - Trigger a panic in the thread. Note that this doesn't panic main.
 - Access the panic payload. This is a good time to talk about `Any`.
- Now we can return values from threads! What about taking inputs?
 - Capture something by reference in the thread closure.
 - An error message indicates we must move it.
 - Move it in, see we can compute and then return a derived value.
- If we want to borrow?
 - Main kills child threads when it returns, but another function would just return and leave them running.
 - That would be stack use-after-return, which violates memory safety!
 - How do we avoid this? See next slide.

57.2 Kapsamlı İş Parçacıkları (Threads)

Normal threads cannot borrow from their environment:

```
use std::thread;

fn foo() {
    let s = String::from("Merhaba");
    thread::spawn(|| {
        println!("Length: {}", s.len());
    });
}

fn main() {
    foo();
}
```

However, you can use a **scoped thread** for this:

```
use std::thread;

fn foo() {
    let s = String::from("Merhaba");
    thread::scope(|scope| {
        scope.spawn(|| {
            println!("Length: {}", s.len());
        });
    });
}

fn main() {
    foo();
}
```

- The reason for that is that when the `thread::scope` function completes, all the threads are guaranteed to be joined, so they can return borrowed data.
- Normal Rust borrowing rules apply: you can either borrow mutably by one thread, or immutably by any number of threads.

Bölüm 58

Kanallar

Bu bölüm yaklaşık 20 dakika sürmelidir. İçeriği:

Slayt	Süre
Vericiler ve Alıcılar	10 dakika
Sınırsız Kanallar	2 dakika
Sınırlı Kanallar	10 dakika

58.1 Vericiler ve Alıcılar

Rust channels have two parts: a `Sender<T>` and a `Receiver<T>`. The two parts are connected via the channel, but you only see the end-points.

```
use std::sync::mpsc;

fn main() {
    let (tx, rx) = mpsc::channel();

    tx.send(10).unwrap();
    tx.send(20).unwrap();

    println!("Received: {:?}", rx.recv());
    println!("Received: {:?}", rx.recv());

    let tx2 = tx.clone();
    tx2.send(30).unwrap();
    println!("Received: {:?}", rx.recv());
}
```

- `mpsc` stands for Multi-Producer, Single-Consumer. `Sender` and `SyncSender` implement `Clone` (so you can make multiple producers) but `Receiver` does not.
- `send()` and `recv()` return `Result`. If they return `Err`, it means the counterpart `Sender` or `Receiver` is dropped and the channel is closed.

58.2 Sınırsız Kanallar

You get an unbounded and asynchronous channel with `mpsc::channel()`:

```
use std::sync::mpsc;
use std::thread;
use std::time::Duration;

fn main() {
    let (tx, rx) = mpsc::channel();

    thread::spawn(move || {
        let thread_id = thread::current().id();
        for i in 0..10 {
            tx.send(format!("Message {i}")).unwrap();
            println!("{thread_id:?}: sent Message {i}");
        }
        println!("{thread_id:?}: done");
    });
    thread::sleep(Duration::from_millis(100));

    for msg in rx.iter() {
        println!("Main: got {msg}");
    }
}
```

- An unbounded channel will allocate as much space as is necessary to store pending messages. The `send()` method will not block the calling thread.
- A call to `send()` will abort with an error (that is why it returns `Result`) if the channel is closed. A channel is closed when the receiver is dropped.

58.3 Sınırlı Kanallar

With bounded (synchronous) channels, `send()` can block the current thread:

```
use std::sync::mpsc;
use std::thread;
use std::time::Duration;

fn main() {
    let (tx, rx) = mpsc::sync_channel(3);

    thread::spawn(move || {
        let thread_id = thread::current().id();
        for i in 0..10 {
            tx.send(format!("Message {i}")).unwrap();
            println!("{thread_id:?}: sent Message {i}");
        }
        println!("{thread_id:?}: done");
    });
    thread::sleep(Duration::from_millis(100));
}
```

```
    for msg in rx.iter() {  
        println!("Main: got {msg}");  
    }  
}
```

- Calling `send()` will block the current thread until there is space in the channel for the new message. The thread can be blocked indefinitely if there is nobody who reads from the channel.
- Like unbounded channels, a call to `send()` will abort with an error if the channel is closed.
- A bounded channel with a size of zero is called a "rendezvous channel". Every send will block the current thread until another thread calls `recv()`.

Bölüm 59

Send ve Sync

Bu bölüm yaklaşık 15 dakika sürmelidir. İçeriği:

Slayt	Süre
Marker Özellikleri (Traits)	2 dakika
Send	2 dakika
Sync	2 dakika
Örnekler	10 dakika

59.1 Marker Özellikleri (Traits)

How does Rust know to forbid shared access across threads? The answer is in two traits:

- **Send**: a type T is Send if it is safe to move a T across a thread boundary.
- **Sync**: a type T is Sync if it is safe to move a &T across a thread boundary.

Send and Sync are [unsafe traits](#). The compiler will automatically derive them for your types as long as they only contain Send and Sync types. You can also implement them manually when you know it is valid.

- One can think of these traits as markers that the type has certain thread-safety properties.
- They can be used in the generic constraints as normal traits.

59.2 Send

A type T is **Send** if it is safe to move a T value to another thread.

The effect of moving ownership to another thread is that *destructors* will run in that thread. So the question is when you can allocate a value in one thread and deallocate it in another.

As an example, a connection to the SQLite library must only be accessed from a single thread.

59.3 Sync

A type `T` is **Sync** if it is safe to access a `T` value from multiple threads at the same time.

More precisely, the definition is:

`T` is **Sync** if and only if `&T` is **Send**

This statement is essentially a shorthand way of saying that if a type is thread-safe for shared use, it is also thread-safe to pass references of it across threads.

This is because if a type is **Sync** it means that it can be shared across multiple threads without the risk of data races or other synchronization issues, so it is safe to move it to another thread. A reference to the type is also safe to move to another thread, because the data it references can be accessed from any thread safely.

59.4 Örnekler

Send + Sync

Most types you come across are **Send + Sync**:

- `i8`, `f32`, `bool`, `char`, `&str`, ...
- `(T1, T2)`, `[T; N]`, `&[T]`, `struct { x: T }`, ...
- `String`, `Option<T>`, `Vec<T>`, `Box<T>`, ...
- `Arc<T>`: Explicitly thread-safe via atomic reference count.
- `Mutex<T>`: Explicitly thread-safe via internal locking.
- `mpsc::Sender<T>`: As of 1.72.0.
- `AtomicBool`, `AtomicU8`, ...: Uses special atomic instructions.

The generic types are typically **Send + Sync** when the type parameters are **Send + Sync**.

Send + !Sync

These types can be moved to other threads, but they're not thread-safe. Typically because of interior mutability:

- `mpsc::Receiver<T>`
- `Cell<T>`
- `RefCell<T>`

!Send + Sync

These types are safe to access (via shared references) from multiple threads, but they cannot be moved to another thread:

- `MutexGuard<T: Sync>`: Uses OS level primitives which must be deallocated on the thread which created them. However, an already-locked mutex can have its guarded variable read by any thread with which the guard is shared.

!Send + !Sync

These types are not thread-safe and cannot be moved to other threads:

- `Rc<T>`: each `Rc<T>` has a reference to an `RcBox<T>`, which contains a non-atomic reference count.
- `*const T`, `*mut T`: Rust assumes raw pointers may have special concurrency considerations.

Bölüm 60

Paylaşımlı Durum (State)

Bu bölüm yaklaşık 30 dakika sürmelidir. İçeriği:

Slayt	Süre
Arc	5 dakika
Mutex	15 dakika
Örnek	10 dakika

60.1 Arc

`Arc<T>` allows shared read-only access via `Arc::clone`:

```
use std::sync::Arc;
use std::thread;

fn main() {
    let v = Arc::new(vec![10, 20, 30]);
    let mut handles = Vec::new();
    for _ in 0..5 {
        let v = Arc::clone(&v);
        handles.push(thread::spawn(move || {
            let thread_id = thread::current().id();
            println!("{thread_id:?}: {v:?}");
        }));
    }

    handles.into_iter().for_each(|h| h.join().unwrap());
    println!("v: {v:?}");
}
```

- Arc stands for "Atomic Reference Counted", a thread safe version of Rc that uses atomic operations.
- Arc<T> implements Clone whether or not T does. It implements Send and Sync if and only if T implements them both.

- `Arc::clone()` has the cost of atomic operations that get executed, but after that the use of the `T` is free.
- Beware of reference cycles, `Arc` does not use a garbage collector to detect them.
 - `std::sync::Weak` can help.

60.2 Mutex

`Mutex<T>` ensures mutual exclusion *and* allows mutable access to `T` behind a read-only interface (another form of [interior mutability](#)):

```
use std::sync::Mutex;

fn main() {
    let v = Mutex::new(vec![10, 20, 30]);
    println!("v: {:?}", v.lock().unwrap());

    {
        let mut guard = v.lock().unwrap();
        guard.push(40);
    }

    println!("v: {:?}", v.lock().unwrap());
}
```

Notice how we have a `impl<T: Send> Sync for Mutex<T>` blanket implementation.

- `Mutex` in Rust looks like a collection with just one element --- the protected data.
 - It is not possible to forget to acquire the mutex before accessing the protected data.
- You can get an `&mut T` from an `&Mutex<T>` by taking the lock. The `MutexGuard` ensures that the `&mut T` doesn't outlive the lock being held.
- `Mutex<T>` implements both `Send` and `Sync` if and only if `T` implements `Send`.
- A read-write lock counterpart: `RwLock`.
- Why does `lock()` return a `Result`?
 - If the thread that held the `Mutex` panicked, the `Mutex` becomes "poisoned" to signal that the data it protected might be in an inconsistent state. Calling `lock()` on a poisoned mutex fails with a `PoisonError`. You can call `into_inner()` on the error to recover the data regardless.

60.3 Örnek

Let us see `Arc` and `Mutex` in action:

```
use std::thread;
// use std::sync::{Arc, Mutex};

fn main() {
    let v = vec![10, 20, 30];
    let handle = thread::spawn(|| {
        v.push(10);
    });
    v.push(1000);
}
```

```

    handle.join().unwrap();
    println!("v: {v:?}");
}

```

Possible solution:

```

use std::sync::{Arc, Mutex};
use std::thread;

fn main() {
    let v = Arc::new(Mutex::new(vec![10, 20, 30]));

    let v2 = Arc::clone(&v);
    let handle = thread::spawn(move || {
        let mut v2 = v2.lock().unwrap();
        v2.push(10);
    });

    {
        let mut v = v.lock().unwrap();
        v.push(1000);
    }

    handle.join().unwrap();

    println!("v: {v:?}");
}

```

Notable parts:

- `v` is wrapped in both `Arc` and `Mutex`, because their concerns are orthogonal.
 - Wrapping a `Mutex` in an `Arc` is a common pattern to share mutable state between threads.
- `v: Arc<_>` needs to be cloned as `v2` before it can be moved into another thread. Note `move` was added to the lambda signature.
- Blocks are introduced to narrow the scope of the `LockGuard` as much as possible.

Bölüm 61

Alıştırmalar

Bu bölüm yaklaşık 1 saat 10 dakika sürmelidir. İçeriği:

Slayt	Süre
Filozofların Akşam Yemeği	20 dakika
Çok İş Parçacıklı Link Denetleyicisi	20 dakika
Çözümler	30 dakika

61.1 Filozofların Akşam Yemeği

The dining philosophers problem is a classic problem in concurrency:

Five philosophers dine together at the same table. Each philosopher has their own place at the table. There is a fork between each plate. The dish served is a kind of spaghetti which has to be eaten with two forks. Each philosopher can only alternately think and eat. Moreover, a philosopher can only eat their spaghetti when they have both a left and right fork. Thus two forks will only be available when their two nearest neighbors are thinking, not eating. After an individual philosopher finishes eating, they will put down both forks.

You will need a local [Cargo installation](#) for this exercise. Copy the code below to a file called `src/main.rs`, fill out the blanks, and test that `cargo run` does not deadlock:

```
use std::sync::{mpsc, Arc, Mutex};
use std::thread;
use std::time::Duration;

struct Fork;

struct Philosopher {
    name: String,
    // left_fork: ...
    // right_fork: ...
    // thoughts: ...
}
```

```

}

impl Philosopher {
    fn think(&self) {
        self.thoughts
            .send(format!("Eureka! {} has a new idea!", &self.name))
            .unwrap();
    }

    fn eat(&self) {
        // Pick up forks...
        println!("{}", &self.name);
        thread::sleep(Duration::from_millis(10));
    }
}

static PHILOSOPHERS: [&str] =
    &["Socrates", "Hypatia", "Plato", "Aristotle", "Pythagoras"];

fn main() {
    // Create forks

    // Create philosophers

    // Make each of them think and eat 100 times

    // Output their thoughts
}

```

You can use the following Cargo.toml:

```

[package]
name = "dining-philosophers"
version = "0.1.0"
edition = "2021"

```

- Encourage students to focus first on implementing a solution that "mostly" works.
- The deadlock in the simplest solution is a general concurrency problem and highlights that Rust does not automatically prevent this sort of bug.

61.2 Çok İş Parçacıklı Link Denetleyicisi

Let us use our new knowledge to create a multi-threaded link checker. It should start at a webpage and check that links on the page are valid. It should recursively check other pages on the same domain and keep doing this until all pages have been validated.

For this, you will need an HTTP client such as `request`. You will also need a way to find links, we can use `scraper`. Finally, we'll need some way of handling errors, we will use `thiserror`.

Create a new Cargo project and request it as a dependency with:

```

cargo new link-checker
cd link-checker

```



```
cargo add --features blocking,rustls-tls request
cargo add scraper
cargo add thiserror
```

If cargo add fails with error: no such subcommand, then please edit the Cargo.toml file by hand. Add the dependencies listed below.

The cargo add calls will update the Cargo.toml file to look like this:

```
[package]
name = "link-checker"
version = "0.1.0"
edition = "2021"
publish = false

[dependencies]
request = { version = "0.11.12", features = ["blocking", "rustls-tls"] }
scraper = "0.13.0"
thiserror = "1.0.37"
```

You can now download the start page. Try with a small site such as <https://www.google.org/>.

Your src/main.rs file should look something like this:

```
use request::blocking::Client;
use request::Url;
use scraper::{Html, Selector};
use thiserror::Error;

enum Error {
    RequestError(#[from] request::Error),
    BadResponse(String),
}

struct CrawlCommand {
    url: Url,
    extract_links: bool,
}

fn visit_page(client: &Client, command: &CrawlCommand) -> Result<Vec<Url>, Error> {
    println!("Checking {:?}", command.url);
    let response = client.get(command.url.clone()).send()?;
    if !response.status().is_success() {
        return Err(Error::BadResponse(response.status().to_string()));
    }

    let mut link_urls = Vec::new();
    if !command.extract_links {
        return Ok(link_urls);
    }

    let base_url = response.url().to_owned();
    let body_text = response.text()?;
    let document = Html::parse_document(&body_text);
```

```

let selector = Selector::parse("a").unwrap();
let href_values = document
    .select(&selector)
    .filter_map(|element| element.value().attr("href"));
for href in href_values {
    match base_url.join(href) {
        Ok(link_url) => {
            link_urls.push(link_url);
        }
        Err(err) => {
            println!("On {base_url:#}: ignored unparseable {href:?}: {err}");
        }
    }
}
Ok(link_urls)
}

fn main() {
    let client = Client::new();
    let start_url = Url::parse("https://www.google.org").unwrap();
    let crawl_command = CrawlCommand{ url: start_url, extract_links: true };
    match visit_page(&client, &crawl_command) {
        Ok(links) => println!("Links: {links:#?}"),
        Err(err) => println!("Could not extract links: {err:#?}"),
    }
}

```

Run the code in `src/main.rs` with
`cargo run`

Görevler

- Use threads to check the links in parallel: send the URLs to be checked to a channel and let a few threads check the URLs in parallel.
- Extend this to recursively extract links from all pages on the `www.google.org` domain. Put an upper limit of 100 pages or so so that you don't end up being blocked by the site.
- This is a complex exercise and intended to give students an opportunity to work on a larger project than others. A success condition for this exercise is to get stuck on some "real" issue and work through it with the support of other students or the instructor.

61.3 Çözümler

Filozofların Akşam Yemeği

```

use std::sync::{mpsc, Arc, Mutex};
use std::thread;
use std::time::Duration;

```

```

struct Fork;

struct Philosopher {
    name: String,
    left_fork: Arc<Mutex<Fork>>,
    right_fork: Arc<Mutex<Fork>>,
    thoughts: mpsc::SyncSender<String>,
}

impl Philosopher {
    fn think(&self) {
        self.thoughts
            .send(format!("Eureka! {} has a new idea!", &self.name))
            .unwrap();
    }

    fn eat(&self) {
        println!("{} is trying to eat", &self.name);
        let _left = self.left_fork.lock().unwrap();
        let _right = self.right_fork.lock().unwrap();

        println!("{} is eating...", &self.name);
        thread::sleep(Duration::from_millis(10));
    }
}

static PHILOSOPHERS: &[&str] =
    &["Socrates", "Hypatia", "Plato", "Aristotle", "Pythagoras"];

fn main() {
    let (tx, rx) = mpsc::sync_channel(10);

    let forks = (0..PHILOSOPHERS.len())
        .map(|_| Arc::new(Mutex::new(Fork)))
        .collect::<Vec<_>>();

    for i in 0..forks.len() {
        let tx = tx.clone();
        let mut left_fork = Arc::clone(&forks[i]);
        let mut right_fork = Arc::clone(&forks[(i + 1) % forks.len()]);

        // To avoid a deadlock, we have to break the symmetry
        // somewhere. This will swap the forks without deinitializing
        // either of them.
        if i == forks.len() - 1 {
            std::mem::swap(&mut left_fork, &mut right_fork);
        }

        let philosopher = Philosopher {
            name: PHILOSOPHERS[i].to_string(),
            thoughts: tx,

```

```

        left_fork,
        right_fork,
    };

    thread::spawn(move || {
        for _ in 0..100 {
            philosopher.eat();
            philosopher.think();
        }
    });
}

drop(tx);
for thought in rx {
    println!("{}", thought);
}
}

```

Link Checker

```

use std::sync::{mpsc, Arc, Mutex};
use std::thread;

use reqwest::blocking::Client;
use reqwest::Url;
use scraper::{Html, Selector};
use thiserror::Error;

enum Error {
    ReqwestError(#[from] reqwest::Error),
    BadResponse(String),
}

struct CrawlCommand {
    url: Url,
    extract_links: bool,
}

fn visit_page(client: &Client, command: &CrawlCommand) -> Result<Vec<Url>, Error> {
    println!("Checking {:#}", command.url);
    let response = client.get(command.url.clone()).send()?;
    if !response.status().is_success() {
        return Err(Error::BadResponse(response.status().to_string()));
    }

    let mut link_urls = Vec::new();
    if !command.extract_links {
        return Ok(link_urls);
    }

    let base_url = response.url().to_owned();

```

```

let body_text = response.text()?;
let document = Html::parse_document(&body_text);

let selector = Selector::parse("a").unwrap();
let href_values = document
    .select(&selector)
    .filter_map(|element| element.value().attr("href"));
for href in href_values {
    match base_url.join(href) {
        Ok(link_url) => {
            link_urls.push(link_url);
        }
        Err(err) => {
            println!("On {base_url:#}: ignored unparseable {href:?}: {err}");
        }
    }
}
Ok(link_urls)
}

struct CrawlState {
    domain: String,
    visited_pages: std::collections::HashSet<String>,
}

impl CrawlState {
    fn new(start_url: &Url) -> CrawlState {
        let mut visited_pages = std::collections::HashSet::new();
        visited_pages.insert(start_url.as_str().to_string());
        CrawlState { domain: start_url.domain().unwrap().to_string(), visited_pages }
    }

    /// Determine whether links within the given page should be extracted.
    fn should_extract_links(&self, url: &Url) -> bool {
        let Some(url_domain) = url.domain() else {
            return false;
        };
        url_domain == self.domain
    }

    /// Mark the given page as visited, returning false if it had already
    /// been visited.
    fn mark_visited(&mut self, url: &Url) -> bool {
        self.visited_pages.insert(url.as_str().to_string())
    }
}

type CrawlResult = Result<Vec<Url>, (Url, Error)>;
fn spawn_crawler_threads(
    command_receiver: mpsc::Receiver<CrawlCommand>,
    result_sender: mpsc::Sender<CrawlResult>,

```

```

thread_count: u32,
) {
    let command_receiver = Arc::new(Mutex::new(command_receiver));

    for _ in 0..thread_count {
        let result_sender = result_sender.clone();
        let command_receiver = command_receiver.clone();
        thread::spawn(move || {
            let client = Client::new();
            loop {
                let command_result = {
                    let receiver_guard = command_receiver.lock().unwrap();
                    receiver_guard.recv()
                };
                let Ok(crawl_command) = command_result else {
                    // The sender got dropped. No more commands coming in.
                    break;
                };
                let crawl_result = match visit_page(&client, &crawl_command) {
                    Ok(link_urls) => Ok(link_urls),
                    Err(error) => Err((crawl_command.url, error)),
                };
                result_sender.send(crawl_result).unwrap();
            }
        });
    }
}

fn control_crawl(
    start_url: Url,
    command_sender: mpsc::Sender<CrawlCommand>,
    result_receiver: mpsc::Receiver<CrawlResult>,
) -> Vec<Url> {
    let mut crawl_state = CrawlState::new(&start_url);
    let start_command = CrawlCommand { url: start_url, extract_links: true };
    command_sender.send(start_command).unwrap();
    let mut pending_urls = 1;

    let mut bad_urls = Vec::new();
    while pending_urls > 0 {
        let crawl_result = result_receiver.recv().unwrap();
        pending_urls -= 1;

        match crawl_result {
            Ok(link_urls) => {
                for url in link_urls {
                    if crawl_state.mark_visited(&url) {
                        let extract_links = crawl_state.should_extract_links(&url);
                        let crawl_command = CrawlCommand { url, extract_links };
                        command_sender.send(crawl_command).unwrap();
                        pending_urls += 1;
                    }
                }
            }
        }
    }
}

```

```

        }
    }
}
Err((url, error)) => {
    bad_urls.push(url);
    println!("Got crawling error: {:#}", error);
    continue;
}
}
}
bad_urls
}

fn check_links(start_url: Url) -> Vec<Url> {
    let (result_sender, result_receiver) = mpsc::channel::<CrawlResult>();
    let (command_sender, command_receiver) = mpsc::channel::<CrawlCommand>();
    spawn_crawler_threads(command_receiver, result_sender, 16);
    control_crawl(start_url, command_sender, result_receiver)
}

fn main() {
    let start_url = reqwest::Url::parse("https://www.google.org").unwrap();
    let bad_urls = check_links(start_url);
    println!("Bad URLs: {:#?}", bad_urls);
}

```

Kısım XIV

Eşzamanlılık: Öğleden Sonra

Bölüm 62

Hoş Geldiniz

"Async" is a concurrency model where multiple tasks are executed concurrently by executing each task until it would block, then switching to another task that is ready to make progress. The model allows running a larger number of tasks on a limited number of threads. This is because the per-task overhead is typically very low and operating systems provide primitives for efficiently identifying I/O that is able to proceed.

Rust's asynchronous operation is based on "futures", which represent work that may be completed in the future. Futures are "polled" until they signal that they are complete.

Futures are polled by an async runtime, and several different runtimes are available.

Karşılaştırmalar

- Python has a similar model in its `asyncio`. However, its `Future` type is callback-based, and not polled. Async Python programs require a "loop", similar to a runtime in Rust.
- JavaScript's `Promise` is similar, but again callback-based. The language runtime implements the event loop, so many of the details of `Promise` resolution are hidden.

Zamanlama (Schedule)

Bu oturum 10 dakikalık aralar dahil yaklaşık 3 saat 20 dakika sürmelidir. İçeriği:

Bölüm	Süre
Async Temelleri	30 dakika
Kanallar ve Kontrol Akışı	20 dakika
Tuzaklar	55 dakika
Alıştırmalar	1 saat 10 dakika

Bölüm 63

Async Temelleri

Bu bölüm yaklaşık 30 dakika sürmelidir. İçeriği:

Slayt	Süre
async/await	10 dakika
Future Özellikleri (Traits)	4 dakika
Çalışma Zamanları	10 dakika
Görevler	10 dakika

63.1 async/await

At a high level, async Rust code looks very much like "normal" sequential code:

```
use futures::executor::block_on;

async fn count_to(count: i32) {
    for i in 0..count {
        println!("Count is: {i}!");
    }
}

async fn async_main(count: i32) {
    count_to(count).await;
}

fn main() {
    block_on(async_main(10));
}
```

Anahtar noktalar:

- Note that this is a simplified example to show the syntax. There is no long running operation or any real concurrency in it!

- The "async" keyword is syntactic sugar. The compiler replaces the return type with a future.
- You cannot make main async, without additional instructions to the compiler on how to use the returned future.
- You need an executor to run async code. `block_on` blocks the current thread until the provided future has run to completion.
- `.await` asynchronously waits for the completion of another operation. Unlike `block_on`, `.await` doesn't block the current thread.
- `.await` can only be used inside an async function (or block; these are introduced later).

63.2 Future Özellikleri (Traits)

Future is a trait, implemented by objects that represent an operation that may not be complete yet. A future can be polled, and `poll` returns a **Poll**.

```
use std::pin::Pin;
use std::task::Context;

pub trait Future {
    type Output;
    fn poll(self: Pin<&mut Self>, cx: &mut Context<'_>) -> Poll<Self::Output>;
}

pub enum Poll<T> {
    Ready(T),
    Pending,
}
```

An async function returns an `impl Future`. It's also possible (but uncommon) to implement `Future` for your own types. For example, the `JoinHandle` returned from `tokio::spawn` implements `Future` to allow joining to it.

The `.await` keyword, applied to a `Future`, causes the current async function to pause until that `Future` is ready, and then evaluates to its output.

- The `Future` and `Poll` types are implemented exactly as shown; click the links to show the implementations in the docs.
- We will not get to `Pin` and `Context`, as we will focus on writing async code, rather than building new async primitives. Briefly:
 - `Context` allows a `Future` to schedule itself to be polled again when an event occurs.
 - `Pin` ensures that the `Future` isn't moved in memory, so that pointers into that future remain valid. This is required to allow references to remain valid after an `.await`.

63.3 Çalışma Zamanları

A *runtime* provides support for performing operations asynchronously (a *reactor*) and is responsible for executing futures (an *executor*). Rust does not have a "built-in" runtime, but

several options are available:

- **Tokio**: performant, with a well-developed ecosystem of functionality like **Hyper** for HTTP or **Tonic** for gRPC.
- **async-std**: aims to be a "std for async", and includes a basic runtime in `async::task`.
- **smol**: simple and lightweight

Several larger applications have their own runtimes. For example, **Fuchsia** already has one.

- Note that of the listed runtimes, only Tokio is supported in the Rust playground. The playground also does not permit any I/O, so most interesting async things can't run in the playground.
- Futures are "inert" in that they do not do anything (not even start an I/O operation) unless there is an executor polling them. This differs from JS Promises, for example, which will run to completion even if they are never used.

63.3.1 Tokio Kasasi

Tokio provides:

- A multi-threaded runtime for executing asynchronous code.
- An asynchronous version of the standard library.
- A large ecosystem of libraries.

```
use tokio::time;
```

```
async fn count_to(count: i32) {
    for i in 0..count {
        println!("Count in task: {i}!");
        time::sleep(time::Duration::from_millis(5)).await;
    }
}
```

```
async fn main() {
    tokio::spawn(count_to(10));

    for i in 0..5 {
        println!("Main task: {i}");
        time::sleep(time::Duration::from_millis(5)).await;
    }
}
```

- With the `tokio::main` macro we can now make `main` async.
- The `spawn` function creates a new, concurrent "task".
- Note: `spawn` takes a Future, you don't call `.await` on `count_to`.

Further exploration:

- Why does `count_to` not (usually) get to 10? This is an example of async cancellation. `tokio::spawn` returns a handle which can be awaited to wait until it finishes.
- Try `count_to(10).await` instead of spawning.
- Try awaiting the task returned from `tokio::spawn`.

63.4 Görevler

Rust has a task system, which is a form of lightweight threading.

A task has a single top-level future which the executor polls to make progress. That future may have one or more nested futures that its poll method polls, corresponding loosely to a call stack. Concurrency within a task is possible by polling multiple child futures, such as racing a timer and an I/O operation.

```
use tokio::io::{self, AsyncReadExt, AsyncWriteExt};
use tokio::net::TcpListener;

async fn main() -> io::Result<()> {
    let listener = TcpListener::bind("127.0.0.1:0").await?;
    println!("listening on port {}", listener.local_addr()?.port());

    loop {
        let (mut socket, addr) = listener.accept().await?;

        println!("connection from {addr:?}");

        tokio::spawn(async move {
            socket.write_all(b"Who are you?\n").await.expect("socket error");

            let mut buf = vec![0; 1024];
            let name_size = socket.read(&mut buf).await.expect("socket error");
            let name = std::str::from_utf8(&buf[..name_size]).unwrap().trim();
            let reply = format!("Thanks for dialing in, {name}!\n");
            socket.write_all(reply.as_bytes()).await.expect("socket error");
        });
    }
}
```

Copy this example into your prepared `src/main.rs` and run it from there.

Try connecting to it with a TCP connection tool like `nc` or `telnet`.

- Ask students to visualize what the state of the example server would be with a few connected clients. What tasks exist? What are their Futures?
- This is the first time we've seen an `async` block. This is similar to a closure, but does not take any arguments. Its return value is a Future, similar to an `async fn`.
- Refactor the `async` block into a function, and improve the error handling using `?`.

Bölüm 64

Kanallar ve Kontrol Akışı

Bu bölüm yaklaşık 20 dakika sürmelidir. İçeriği:

Slayt	Süre
Async Kanalları	10 dakika
Join	4 dakika
Select	5 dakika

64.1 Async Kanalları

Several crates have support for asynchronous channels. For instance tokio:

```
use tokio::sync::mpsc;

async fn ping_handler(mut input: mpsc::Receiver<()>) {
    let mut count: usize = 0;

    while let Some(_) = input.recv().await {
        count += 1;
        println!("Received {count} pings so far.");
    }

    println!("ping_handler complete");
}

async fn main() {
    let (sender, receiver) = mpsc::channel(32);
    let ping_handler_task = tokio::spawn(ping_handler(receiver));
    for i in 0..10 {
        sender.send(()).await.expect("Failed to send ping.");
        println!("Sent {} pings so far.", i + 1);
    }

    drop(sender);
}
```

```
ping_handler_task.await.expect("Something went wrong in ping handler task.");
}
```

- Change the channel size to 3 and see how it affects the execution.
- Overall, the interface is similar to the sync channels as seen in the [morning class](#).
- Try removing the `std::mem::drop` call. What happens? Why?
- The [Flume](#) crate has channels that implement both sync and async send and recv. This can be convenient for complex applications with both IO and heavy CPU processing tasks.
- What makes working with async channels preferable is the ability to combine them with other futures to combine them and create complex control flow.

64.2 Join

A join operation waits until all of a set of futures are ready, and returns a collection of their results. This is similar to `Promise.all` in JavaScript or `asyncio.gather` in Python.

```
use anyhow::Result;
use futures::future;
use reqwest;
use std::collections::HashMap;

async fn size_of_page(url: &str) -> Result<usize> {
    let resp = reqwest::get(url).await?;
    Ok(resp.text().await?.len())
}

async fn main() {
    let urls: [&str; 4] = [
        "https://google.com",
        "https://httpbin.org/ip",
        "https://play.rust-lang.org/",
        "BAD_URL",
    ];
    let futures_iter = urls.into_iter().map(size_of_page);
    let results = future::join_all(futures_iter).await;
    let page_sizes_dict: HashMap<&str, Result<usize>> =
        urls.into_iter().zip(results.into_iter()).collect();
    println!("{}", page_sizes_dict);
}
```

Copy this example into your prepared `src/main.rs` and run it from there.

- For multiple futures of disjoint types, you can use `std::future::join!` but you must know how many futures you will have at compile time. This is currently in the `futures` crate, soon to be stabilised in `std::future`.
- The risk of `join` is that one of the futures may never resolve, this would cause your program to stall.

- You can also combine `join_all` with `join!` for instance to join all requests to an http service as well as a database query. Try adding a `tokio::time::sleep` to the future, using `futures::join!`. This is not a timeout (that requires `select!`, explained in the next chapter), but demonstrates `join!`.

64.3 Select

A select operation waits until any of a set of futures is ready, and responds to that future's result. In JavaScript, this is similar to `Promise.race`. In Python, it compares to `asyncio.wait(task_set, return_when=asyncio.FIRST_COMPLETED)`.

Similar to a match statement, the body of `select!` has a number of arms, each of the form `pattern = future => statement`. When a future is ready, its return value is destructured by the pattern. The statement is then run with the resulting variables. The statement result becomes the result of the `select!` macro.

```
use tokio::sync::mpsc;
use tokio::time::{sleep, Duration};

async fn main() {
    let (tx, mut rx) = mpsc::channel(32);
    let listener = tokio::spawn(async move {
        tokio::select! {
            Some(msg) = rx.recv() => println!("got: {msg}"),
            _ = sleep(Duration::from_millis(50)) => println!("timeout"),
        };
    });
    sleep(Duration::from_millis(10)).await;
    tx.send(String::from("Merhaba!")).await.expect("Failed to send greeting");

    listener.await.expect("Listener failed");
}
```

- The `listener` async block here is a common form: wait for some async event, or for a timeout. Change the `sleep` to sleep longer to see it fail. Why does the `send` also fail in this situation?
- `select!` is also often used in a loop in "actor" architectures, where a task reacts to events in a loop. That has some pitfalls, which will be discussed in the next segment.

Bölüm 65

Tuzaklar

Async / await provides convenient and efficient abstraction for concurrent asynchronous programming. However, the async/await model in Rust also comes with its share of pitfalls and footguns. We illustrate some of them in this chapter.

Bu bölüm yaklaşık 55 dakika sürmelidir. İçerir:

Slayt	Süre
Yürütücünün/Çalıştırıcının (Executor) Engellenmesi	10 dakika
Pin	20 dakika
Async Özellikleri (Traits)	5 dakika
İptal (Cancellation)	20 dakika

65.1 Blocking the executor

Most async runtimes only allow IO tasks to run concurrently. This means that CPU blocking tasks will block the executor and prevent other tasks from being executed. An easy workaround is to use async equivalent methods where possible.

```
use futures::future::join_all;
use std::time::Instant;

async fn sleep_ms(start: &Instant, id: u64, duration_ms: u64) {
    std::thread::sleep(std::time::Duration::from_millis(duration_ms));
    println!(
        "future {id} slept for {duration_ms}ms, finished after {}ms",
        start.elapsed().as_millis()
    );
}

async fn main() {
    let start = Instant::now();
    let sleep_futures = (1..=10).map(|t| sleep_ms(&start, t, t * 10));
```

```

    join_all(sleep_futures).await;
}

```

- Run the code and see that the sleeps happen consecutively rather than concurrently.
- The "current_thread" flavor puts all tasks on a single thread. This makes the effect more obvious, but the bug is still present in the multi-threaded flavor.
- Switch the `std::thread::sleep` to `tokio::time::sleep` and await its result.
- Another fix would be to `tokio::task::spawn_blocking` which spawns an actual thread and transforms its handle into a future without blocking the executor.
- You should not think of tasks as OS threads. They do not map 1 to 1 and most executors will allow many tasks to run on a single OS thread. This is particularly problematic when interacting with other libraries via FFI, where that library might depend on thread-local storage or map to specific OS threads (e.g., CUDA). Prefer `tokio::task::spawn_blocking` in such situations.
- Use sync mutexes with care. Holding a mutex over an `.await` may cause another task to block, and that task may be running on the same thread.

65.2 Pin

Async blocks and functions return types implementing the `Future` trait. The type returned is the result of a compiler transformation which turns local variables into data stored inside the future.

Some of those variables can hold pointers to other local variables. Because of that, the future should never be moved to a different memory location, as it would invalidate those pointers.

To prevent moving the future type in memory, it can only be polled through a pinned pointer. `Pin` is a wrapper around a reference that disallows all operations that would move the instance it points to into a different memory location.

```

use tokio::sync::{mpsc, oneshot};
use tokio::task::spawn;
use tokio::time::{sleep, Duration};

// A work item. In this case, just sleep for the given time and respond
// with a message on the `respond_on` channel.
struct Work {
    input: u32,
    respond_on: oneshot::Sender<u32>,
}

// A worker which listens for work on a queue and performs it.
async fn worker(mut work_queue: mpsc::Receiver<Work>) {
    let mut iterations = 0;
    loop {
        tokio::select! {
            Some(work) = work_queue.recv() => {
                sleep(Duration::from_millis(10)).await; // Pretend to work.
                work.respond_on

```

```

        .send(work.input * 1000)
        .expect("failed to send response");
        iterations += 1;
    }
    // TODO: report number of iterations every 100ms
}
}
}

// A requester which requests work and waits for it to complete.
async fn do_work(work_queue: &mpsc::Sender<Work>, input: u32) -> u32 {
    let (tx, rx) = oneshot::channel();
    work_queue
        .send(Work { input, respond_on: tx })
        .await
        .expect("failed to send on work queue");
    rx.await.expect("failed waiting for response")
}

async fn main() {
    let (tx, rx) = mpsc::channel(10);
    spawn(worker(rx));
    for i in 0..100 {
        let resp = do_work(&tx, i).await;
        println!("work result for iteration {i}: {resp}");
    }
}

```

- You may recognize this as an example of the actor pattern. Actors typically call `select!` in a loop.
- This serves as a summation of a few of the previous lessons, so take your time with it.
 - Naively `add_a_ = sleep(Duration::from_millis(100)) => { println!(..) }` to the `select!`. This will never execute. Why?
 - Instead, add a `timeout_fut` containing that future outside of the loop:

```

let timeout_fut = sleep(Duration::from_millis(100));
loop {
    select! {
        ..,
        _ = timeout_fut => { println!(..); },
    }
}

```

- This still doesn't work. Follow the compiler errors, adding `&mut` to the `timeout_fut` in the `select!` to work around the move, then using `Box::pin`:

```

let mut timeout_fut = Box::pin(sleep(Duration::from_millis(100)));
loop {
    select! {
        ..,
        _ = &mut timeout_fut => { println!(..); },
    }
}

```

```
    }
}
```

- This compiles, but once the timeout expires it is `Poll::Ready` on every iteration (a fused future would help with this). Update to reset `timeout_fut` every time it expires:

```
let mut timeout_fut = Box::pin(sleep(Duration::from_millis(100)));
loop {
    select! {
        _ = &mut timeout_fut => {
            println!(..);
            timeout_fut = Box::pin(sleep(Duration::from_millis(100)));
        },
    }
}
```

- `Box` allocates on the heap. In some cases, `std::pin::pin!` (only recently stabilized, with older code often using `tokio::pin!`) is also an option, but that is difficult to use for a future that is reassigned.
- Another alternative is to not use `pin` at all but spawn another task that will send to a `oneshot` channel every 100ms.
- Data that contains pointers to itself is called self-referential. Normally, the Rust borrow checker would prevent self-referential data from being moved, as the references cannot outlive the data they point to. However, the code transformation for `async` blocks and functions is not verified by the borrow checker.
- `Pin` is a wrapper around a reference. An object cannot be moved from its place using a pinned pointer. However, it can still be moved through an unpinned pointer.
- The `poll` method of the `Future` trait uses `Pin<&mut Self>` instead of `&mut Self` to refer to the instance. That's why it can only be called on a pinned pointer.

65.3 Async Özellikleri (Traits)

Async methods in traits were stabilized in the 1.75 release. This required support for using return-position `impl Trait` in traits, as the desugaring for `async fn` includes `-> impl Future<Output = ...>`.

However, even with the native support, there are some pitfalls around `async fn`:

- Return-position `impl Trait` captures all in-scope lifetimes (so some patterns of borrowing cannot be expressed).
- Async traits cannot be used with [trait objects](#) (`dyn Trait` support).

The `async_trait` crate provides a workaround for `dyn` support through a macro, with some caveats:

```
use async_trait::async_trait;
use std::time::Instant;
use tokio::time::{sleep, Duration};

trait Sleeper {
```

```

    async fn sleep(&self);
}

struct FixedSleeper {
    sleep_ms: u64,
}

impl Sleeper for FixedSleeper {
    async fn sleep(&self) {
        sleep(Duration::from_millis(self.sleep_ms)).await;
    }
}

async fn run_all_sleepers_multiple_times(
    sleepers: Vec<Box<dyn Sleeper>>,
    n_times: usize,
) {
    for _ in 0..n_times {
        println!("Running all sleepers...");
        for sleeper in &sleepers {
            let start = Instant::now();
            sleeper.sleep().await;
            println!("Slept for {} ms", start.elapsed().as_millis());
        }
    }
}

async fn main() {
    let sleepers: Vec<Box<dyn Sleeper>> = vec![
        Box::new(FixedSleeper { sleep_ms: 50 }),
        Box::new(FixedSleeper { sleep_ms: 100 }),
    ];
    run_all_sleepers_multiple_times(sleepers, 5).await;
}

```

- `async_trait` is easy to use, but note that it's using heap allocations to achieve this. This heap allocation has performance overhead.
- The challenges in language support for `async trait` are too deep to describe in-depth in this class. See [this blog post](#) by Niko Matsakis if you are interested in digging deeper. See also these keywords:
 - **RPIT**: short for `return-position impl Trait`.
 - **RPITIT**: short for `return-position impl Trait in trait` (RPIT in trait).
- Try creating a new sleeper struct that will sleep for a random amount of time and adding it to the `Vec`.

65.4 Iptal (Cancellation)

Dropping a future implies it can never be polled again. This is called *cancellation* and it can occur at any `await` point. Care is needed to ensure the system works correctly even when

futures are cancelled. For example, it shouldn't deadlock or lose data.

```
use std::io;
use std::time::Duration;
use tokio::io::{AsyncReadExt, AsyncWriteExt, DuplexStream};

struct LinesReader {
    stream: DuplexStream,
}

impl LinesReader {
    fn new(stream: DuplexStream) -> Self {
        Self { stream }
    }

    async fn next(&mut self) -> io::Result<Option<String>> {
        let mut bytes = Vec::new();
        let mut buf = [0];
        while self.stream.read(&mut buf[..]).await? != 0 {
            bytes.push(buf[0]);
            if buf[0] == b'\n' {
                break;
            }
        }
        if bytes.is_empty() {
            return Ok(None);
        }
        let s = String::from_utf8(bytes)
            .map_err(|_| io::Error::new(io::ErrorKind::InvalidData, "not UTF-8"))?;
        Ok(Some(s))
    }
}

async fn slow_copy(source: String, mut dest: DuplexStream) -> io::Result<()> {
    for b in source.bytes() {
        dest.write_u8(b).await?;
        tokio::time::sleep(Duration::from_millis(10)).await
    }
    Ok(())
}

async fn main() -> io::Result<()> {
    let (client, server) = tokio::io::duplex(5);
    let handle = tokio::spawn(slow_copy("hi\nthere\n".to_owned(), client));

    let mut lines = LinesReader::new(server);
    let mut interval = tokio::time::interval(Duration::from_millis(60));
    loop {
        tokio::select! {
            _ = interval.tick() => println!("tick!"),
            line = lines.next() => if let Some(l) = line? {

```

```

        print!("{}", l)
    } else {
        break
    },
}
}
}
handle.await.unwrap()?;
Ok(())
}

```

- The compiler doesn't help with cancellation-safety. You need to read API documentation and consider what state your `async fn` holds.
- Unlike `panic` and `?`, cancellation is part of normal control flow (vs error-handling).
- The example loses parts of the string.

- Whenever the `tick()` branch finishes first, `next()` and its `buf` are dropped.
- `LinesReader` can be made cancellation-safe by making `buf` part of the struct:

```

struct LinesReader {
    stream: DuplexStream,
    bytes: Vec<u8>,
    buf: [u8; 1],
}

impl LinesReader {
    fn new(stream: DuplexStream) -> Self {
        Self { stream, bytes: Vec::new(), buf: [0] }
    }
    async fn next(&mut self) -> io::Result<Option<String>> {
        // prefix buf and bytes with self.
        // ...
        let raw = std::mem::take(&mut self.bytes);
        let s = String::from_utf8(raw)
            .map_err(|_| io::Error::new(io::ErrorKind::InvalidData, "not UTF-8"))
        // ...
    }
}

```

- `Interval::tick` is cancellation-safe because it keeps track of whether a tick has been 'delivered'.
- `AsyncReadExt::read` is cancellation-safe because it either returns or doesn't read data.
- `AsyncBufReadExt::read_line` is similar to the example and *isn't* cancellation-safe. See its documentation for details and alternatives.

Bölüm 66

Alıştırmalar

Bu bölüm yaklaşık 1 saat 10 dakika sürmelidir. İçeriği:

Slayt	Süre
Filozofların Akşam Yemeği	20 dakika
Yayımlamalı Sohbet Uygulaması	30 dakika
Çözümler	20 dakika

66.1 Filozofların Akşam Yemeği --- Async

See [dining philosophers](#) for a description of the problem.

As before, you will need a local [Cargo installation](#) for this exercise. Copy the code below to a file called `src/main.rs`, fill out the blanks, and test that `cargo run` does not deadlock:

```
use std::sync::Arc;
use tokio::sync::{mpsc, Mutex};
use tokio::time;

struct Fork;

struct Philosopher {
    name: String,
    // left_fork: ...
    // right_fork: ...
    // thoughts: ...
}

impl Philosopher {
    async fn think(&self) {
        self.thoughts
            .send(format!("Eureka! {} has a new idea!", &self.name))
            .await
            .unwrap();
    }
}
```



```

    }

    async fn eat(&self) {
        // Keep trying until we have both forks
        println!("{}", &self.name);
        time::sleep(time::Duration::from_millis(5)).await;
    }
}

static PHILOSOPHERS: [&str] =
    &["Socrates", "Hypatia", "Plato", "Aristotle", "Pythagoras"];

async fn main() {
    // Create forks

    // Create philosophers

    // Make them think and eat

    // Output their thoughts
}

```

Since this time you are using Async Rust, you'll need a tokio dependency. You can use the following Cargo.toml:

```

[package]
name = "dining-philosophers-async-dine"
version = "0.1.0"
edition = "2021"

[dependencies]
tokio = { version = "1.26.0", features = ["sync", "time", "macros", "rt-multi-thread"]
}

```

Also note that this time you have to use the Mutex and the mpsc module from the tokio crate.

- Can you make your implementation single-threaded?

66.2 Yayımlamalı Sohbet Uygulaması

In this exercise, we want to use our new knowledge to implement a broadcast chat application. We have a chat server that the clients connect to and publish their messages. The client reads user messages from the standard input, and sends them to the server. The chat server broadcasts each message that it receives to all the clients.

For this, we use a **broadcast channel** on the server, and **tokio_websockets** for the communication between the client and the server.

Create a new Cargo project and add the following dependencies:

Cargo.toml:

```

[package]
name = "chat-async"
version = "0.1.0"

```

```
edition = "2021"
```

[dependencies]

```
futures-util = { version = "0.3.31", features = ["sink"] }
```

```
http = "1.1.0"
```

```
tokio = { version = "1.41.1", features = ["full"] }
```

```
tokio-websockets = { version = "0.10.1", features = ["client", "fastrand", "server", "s"] }
```

The required APIs

You are going to need the following functions from `tokio` and `tokio_websockets`. Spend a few minutes to familiarize yourself with the API.

- `StreamExt::next()` implemented by `WebSocketStream`: for asynchronously reading messages from a `WebSocketStream`.
- `SinkExt::send()` implemented by `WebSocketStream`: for asynchronously sending messages on a `WebSocketStream`.
- `Lines::next_line()`: for asynchronously reading user messages from the standard input.
- `Sender::subscribe()`: for subscribing to a broadcast channel.

Two binaries

Normally in a Cargo project, you can have only one binary, and one `src/main.rs` file. In this project, we need two binaries. One for the client, and one for the server. You could potentially make them two separate Cargo projects, but we are going to put them in a single Cargo project with two binaries. For this to work, the client and the server code should go under `src/bin` (see the [documentation](#)).

Copy the following server and client code into `src/bin/server.rs` and `src/bin/client.rs`, respectively. Your task is to complete these files as described below.

src/bin/server.rs:

```
use futures_util::sink::SinkExt;
use futures_util::stream::StreamExt;
use std::error::Error;
use std::net::SocketAddr;
use tokio::net::{TcpListener, TcpStream};
use tokio::sync::broadcast::{channel, Sender};
use tokio_websockets::{Message, ServerBuilder, WebSocketStream};
```

```
async fn handle_connection(
    addr: SocketAddr,
    mut ws_stream: WebSocketStream<TcpStream>,
    bcast_tx: Sender<String>,
) -> Result<(), Box<dyn Error + Send + Sync>> {

    // TODO: For a hint, see the description of the task below.

}
```

```
async fn main() -> Result<(), Box<dyn Error + Send + Sync>> {
```

```

let (bcast_tx, _) = channel(16);

let listener = TcpListener::bind("127.0.0.1:2000").await?;
println!("listening on port 2000");

loop {
    let (socket, addr) = listener.accept().await?;
    println!("New connection from {addr:?}");
    let bcast_tx = bcast_tx.clone();
    tokio::spawn(async move {
        // Wrap the raw TCP stream into a websocket.
        let ws_stream = ServerBuilder::new().accept(socket).await?;

        handle_connection(addr, ws_stream, bcast_tx).await
    });
}
}

src/bin/client.rs:

use futures_util::stream::StreamExt;
use futures_util::SinkExt;
use http::Uri;
use tokio::io::{AsyncBufReadExt, BufReader};
use tokio_websockets::{ClientBuilder, Message};

async fn main() -> Result<(), tokio_websockets::Error> {
    let (mut ws_stream, _) =
        ClientBuilder::from_uri(Uri::from_static("ws://127.0.0.1:2000"))
            .connect()
            .await?;

    let stdin = tokio::io::stdin();
    let mut stdin = BufReader::new(stdin).lines();

    // TODO: For a hint, see the description of the task below.
}

```

Running the binaries

Run the server with:

```
cargo run --bin server
```

and the client with:

```
cargo run --bin client
```

Görevler

- Implement the `handle_connection` function in `src/bin/server.rs`.

- Hint: Use `tokio::select!` for concurrently performing two tasks in a continuous loop. One task receives messages from the client and broadcasts them. The other sends messages received by the server to the client.
- Complete the main function in `src/bin/client.rs`.
 - Hint: As before, use `tokio::select!` in a continuous loop for concurrently performing two tasks: (1) reading user messages from standard input and sending them to the server, and (2) receiving messages from the server, and displaying them for the user.
- Optional: Once you are done, change the code to broadcast messages to all clients, but the sender of the message.

66.3 Çözümler

Filozofların Akşam Yemeği --- Async

```
use std::sync::Arc;
use tokio::sync::{mpsc, Mutex};
use tokio::time;

struct Fork;

struct Philosopher {
    name: String,
    left_fork: Arc<Mutex<Fork>>,
    right_fork: Arc<Mutex<Fork>>,
    thoughts: mpsc::Sender<String>,
}

impl Philosopher {
    async fn think(&self) {
        self.thoughts
            .send(format!("Eureka! {} has a new idea!", &self.name))
            .await
            .unwrap();
    }

    async fn eat(&self) {
        // Keep trying until we have both forks
        // Pick up forks...
        let _left_fork = self.left_fork.lock().await;
        let _right_fork = self.right_fork.lock().await;

        println!("{}", &self.name);
        time::sleep(time::Duration::from_millis(5)).await;

        // The locks are dropped here
    }
}

static PHILOSOPHERS: &[&str] =
```

```

    &["Socrates", "Hypatia", "Plato", "Aristotle", "Pythagoras"];

async fn main() {
    // Create forks
    let mut forks = vec![];
    (0..PHILOSOPHERS.len()).for_each(|_| forks.push(Arc::new(Mutex::new(Fork))));

    // Create philosophers
    let (philosophers, mut rx) = {
        let mut philosophers = vec![];
        let (tx, rx) = mpsc::channel(10);
        for (i, name) in PHILOSOPHERS.iter().enumerate() {
            let mut left_fork = Arc::clone(&forks[i]);
            let mut right_fork = Arc::clone(&forks[(i + 1) % PHILOSOPHERS.len()]);
            if i == PHILOSOPHERS.len() - 1 {
                std::mem::swap(&mut left_fork, &mut right_fork);
            }
            philosophers.push(Philosopher {
                name: name.to_string(),
                left_fork,
                right_fork,
                thoughts: tx.clone(),
            });
        }
        (philosophers, rx)
        // tx is dropped here, so we don't need to explicitly drop it later
    };

    // Make them think and eat
    for phil in philosophers {
        tokio::spawn(async move {
            for _ in 0..100 {
                phil.think().await;
                phil.eat().await;
            }
        });
    }

    // Output their thoughts
    while let Some(thought) = rx.recv().await {
        println!("Here is a thought: {thought}");
    }
}

```

Yayımlamalı Sohbet Uygulaması

src/bin/server.rs:

```

use futures_util::sink::SinkExt;
use futures_util::stream::StreamExt;
use std::error::Error;

```

```

use std::net::SocketAddr;
use tokio::net::{TcpListener, TcpStream};
use tokio::sync::broadcast::{channel, Sender};
use tokio_websockets::{Message, ServerBuilder, WebSocketStream};

async fn handle_connection(
    addr: SocketAddr,
    mut ws_stream: WebSocketStream<TcpStream>,
    bcast_tx: Sender<String>,
) -> Result<(), Box<dyn Error + Send + Sync>> {

    ws_stream
        .send(Message::text("Welcome to chat! Type a message".to_string()))
        .await?;
    let mut bcast_rx = bcast_tx.subscribe();

    // A continuous loop for concurrently performing two tasks: (1) receiving
    // messages from `ws_stream` and broadcasting them, and (2) receiving
    // messages on `bcast_rx` and sending them to the client.
    loop {
        tokio::select! {
            incoming = ws_stream.next() => {
                match incoming {
                    Some(Ok(msg)) => {
                        if let Some(text) = msg.as_text() {
                            println!("From client {addr:?} {text:?}");
                            bcast_tx.send(text.into())?;
                        }
                    }
                    Some(Err(err)) => return Err(err.into()),
                    None => return Ok(()),
                }
            }
            msg = bcast_rx.recv() => {
                ws_stream.send(Message::text(msg?)).await?;
            }
        }
    }
}

async fn main() -> Result<(), Box<dyn Error + Send + Sync>> {
    let (bcast_tx, _) = channel(16);

    let listener = TcpListener::bind("127.0.0.1:2000").await?;
    println!("listening on port 2000");

    loop {
        let (socket, addr) = listener.accept().await?;
        println!("New connection from {addr:?}");
        let bcast_tx = bcast_tx.clone();
        tokio::spawn(async move {

```

```

        // Wrap the raw TCP stream into a websocket.
        let ws_stream = ServerBuilder::new().accept(socket).await?;

        handle_connection(addr, ws_stream, bcast_tx).await
    });
}
}

src/bin/client.rs:
use futures_util::stream::StreamExt;
use futures_util::SinkExt;
use http::Uri;
use tokio::io::{AsyncBufReadExt, BufReader};
use tokio_websockets::{ClientBuilder, Message};

async fn main() -> Result<(), tokio_websockets::Error> {
    let (mut ws_stream, _) =
        ClientBuilder::from_uri(Uri::from_static("ws://127.0.0.1:2000"))
            .connect()
            .await?;

    let stdin = tokio::io::stdin();
    let mut stdin = BufReader::new(stdin).lines();

    // Continuous loop for concurrently sending and receiving messages.
    loop {
        tokio::select! {
            incoming = ws_stream.next() => {
                match incoming {
                    Some(Ok(msg)) => {
                        if let Some(text) = msg.as_text() {
                            println!("From server: {}", text);
                        }
                    },
                    Some(Err(err)) => return Err(err.into()),
                    None => return Ok(()),
                }
            }
            res = stdin.next_line() => {
                match res {
                    Ok(None) => return Ok(()),
                    Ok(Some(line)) => ws_stream.send(Message::text(line.to_string())).await,
                    Err(err) => return Err(err.into()),
                }
            }
        }
    }
}
}
}

```

Kısım XV

Son sözler

Bölüm 67

Teşekkürler!

Thank you for taking Comprehensive Rust 🦀! We hope you enjoyed it and that it was useful.

We've had a lot of fun putting the course together. The course is not perfect, so if you spotted any mistakes or have ideas for improvements, please get in [contact with us on GitHub](#). We would love to hear from you.

- Thank you for reading the speaker notes! We hope they have been useful. If you find pages without notes, please send us a PR and link it to [issue #1083](#). We are also very grateful for fixes and improvements to the existing notes.

Bölüm 68

Sözlük

The following is a glossary which aims to give a short definition of many Rust terms. For translations, this also serves to connect the term back to the English original.

- allocate:
Dynamic memory allocation on [the heap](#).
- argument:
Information that is passed into a function or method.
- associated type:
A type associated with a specific trait. Useful for defining the relationship between types.
- Bare-metal Rust:
Low-level Rust development, often deployed to a system without an operating system. See [Bare-metal Rust](#).
- block:
See [Blocks](#) and *scope*.
- borrow:
See [Borrowing](#).
- borrow checker:
The part of the Rust compiler which checks that all borrows are valid.
- brace:
{ and }. Also called *curly brace*, they delimit *blocks*.
- build:
The process of converting source code into executable code or a usable program.
- call:
To invoke or execute a function or method.
- channel:
Used to safely pass messages [between threads](#).
- Comprehensive Rust 🦀:
The courses here are jointly called Comprehensive Rust 🦀.
- concurrency:
The execution of multiple tasks or processes at the same time.
- Concurrency in Rust:
See [Concurrency in Rust](#).
- constant:
A value that does not change during the execution of a program.

- **control flow:**
The order in which the individual statements or instructions are executed in a program.
- **crash:**
An unexpected and unhandled failure or termination of a program.
- **enumeration:**
A data type that holds one of several named constants, possibly with an associated tuple or struct.
- **error:**
An unexpected condition or result that deviates from the expected behavior.
- **error handling:**
The process of managing and responding to errors that occur during program execution.
- **exercise:**
A task or problem designed to practice and test programming skills.
- **function:**
A reusable block of code that performs a specific task.
- **garbage collector:**
A mechanism that automatically frees up memory occupied by objects that are no longer in use.
- **generics:**
A feature that allows writing code with placeholders for types, enabling code reuse with different data types.
- **immutable:**
Unable to be changed after creation.
- **integration test:**
A type of test that verifies the interactions between different parts or components of a system.
- **keyword:**
A reserved word in a programming language that has a specific meaning and cannot be used as an identifier.
- **library:**
A collection of precompiled routines or code that can be used by programs.
- **macro:**
Rust macros can be recognized by a `!` in the name. Macros are used when normal functions are not enough. A typical example is `format!`, which takes a variable number of arguments, which isn't supported by Rust functions.
- **main function:**
Rust programs start executing with the `main` function.
- **match:**
A control flow construct in Rust that allows for pattern matching on the value of an expression.
- **memory leak:**
A situation where a program fails to release memory that is no longer needed, leading to a gradual increase in memory usage.
- **method:**
A function associated with an object or a type in Rust.
- **module:**
A namespace that contains definitions, such as functions, types, or traits, to organize code in Rust.
- **move:**
The transfer of ownership of a value from one variable to another in Rust.
- **mutable:**

- A property in Rust that allows variables to be modified after they have been declared.
- **ownership:**
The concept in Rust that defines which part of the code is responsible for managing the memory associated with a value.
 - **panic:**
An unrecoverable error condition in Rust that results in the termination of the program.
 - **parameter:**
A value that is passed into a function or method when it is called.
 - **pattern:**
A combination of values, literals, or structures that can be matched against an expression in Rust.
 - **payload:**
The data or information carried by a message, event, or data structure.
 - **program:**
A set of instructions that a computer can execute to perform a specific task or solve a particular problem.
 - **programming language:**
A formal system used to communicate instructions to a computer, such as Rust.
 - **receiver:**
The first parameter in a Rust method that represents the instance on which the method is called.
 - **reference counting:**
A memory management technique in which the number of references to an object is tracked, and the object is deallocated when the count reaches zero.
 - **return:**
A keyword in Rust used to indicate the value to be returned from a function.
 - **Rust:**
A systems programming language that focuses on safety, performance, and concurrency.
 - **Rust Fundamentals:**
Days 1 to 4 of this course.
 - **Rust in Android:**
See [Rust in Android](#).
 - **Rust in Chromium:**
See [Rust in Chromium](#).
 - **safe:**
Refers to code that adheres to Rust's ownership and borrowing rules, preventing memory-related errors.
 - **scope:**
The region of a program where a variable is valid and can be used.
 - **standard library:**
A collection of modules providing essential functionality in Rust.
 - **static:**
A keyword in Rust used to define static variables or items with a 'static' lifetime.
 - **string:**
A data type storing textual data. See [Strings](#) for more.
 - **struct:**
A composite data type in Rust that groups together variables of different types under a single name.
 - **test:**
A Rust module containing functions that test the correctness of other functions.
 - **thread:**

- A separate sequence of execution in a program, allowing concurrent execution.
- **thread safety:**
The property of a program that ensures correct behavior in a multithreaded environment.
 - **trait:**
A collection of methods defined for an unknown type, providing a way to achieve polymorphism in Rust.
 - **trait bound:**
An abstraction where you can require types to implement some traits of your interest.
 - **tuple:**
A composite data type that contains variables of different types. Tuple fields have no names, and are accessed by their ordinal numbers.
 - **type:**
A classification that specifies which operations can be performed on values of a particular kind in Rust.
 - **type inference:**
The ability of the Rust compiler to deduce the type of a variable or expression.
 - **undefined behavior:**
Actions or conditions in Rust that have no specified result, often leading to unpredictable program behavior.
 - **union:**
A data type that can hold values of different types but only one at a time.
 - **unit test:**
Rust comes with built-in support for running small unit tests and larger integration tests. See [Unit Tests](#).
 - **unit type:**
Type that holds no data, written as a tuple with no members.
 - **unsafe:**
The subset of Rust which allows you to trigger *undefined behavior*. See [Unsafe Rust](#).
 - **variable:**
A memory location storing data. Variables are valid in a *scope*.

Bölüm 69

Other Rust Resources

The Rust community has created a wealth of high-quality and free resources online.

Official Documentation

The Rust project hosts many resources. These cover Rust in general:

- **The Rust Programming Language**: the canonical free book about Rust. Covers the language in detail and includes a few projects for people to build.
- **Rust By Example**: covers the Rust syntax via a series of examples which showcase different constructs. Sometimes includes small exercises where you are asked to expand on the code in the examples.
- **Rust Standard Library**: full documentation of the standard library for Rust.
- **The Rust Reference**: an incomplete book which describes the Rust grammar and memory model.

More specialized guides hosted on the official Rust site:

- **The Rustonomicon**: covers unsafe Rust, including working with raw pointers and interfacing with other languages (FFI).
- **Asynchronous Programming in Rust**: covers the new asynchronous programming model which was introduced after the Rust Book was written.
- **The Embedded Rust Book**: an introduction to using Rust on embedded devices without an operating system.

Unofficial Learning Material

A small selection of other guides and tutorial for Rust:

- **Learn Rust the Dangerous Way**: covers Rust from the perspective of low-level C programmers.
- **Rust for Embedded C Programmers**: covers Rust from the perspective of developers who write firmware in C.
- **Rust for professionals**: covers the syntax of Rust using side-by-side comparisons with other languages such as C, C++, Java, JavaScript, and Python.
- **Rust on Exercism**: 100+ exercises to help you learn Rust.

- **Ferrous Teaching Material:** a series of small presentations covering both basic and advanced part of the Rust language. Other topics such as WebAssembly, and async/await are also covered.
- **Advanced testing for Rust applications:** a self-paced workshop that goes beyond Rust's built-in testing framework. It covers googletest, snapshot testing, mocking as well as how to write your own custom test harness.
- **Beginner's Series to Rust** and **Take your first steps with Rust:** two Rust guides aimed at new developers. The first is a set of 35 videos and the second is a set of 11 modules which covers Rust syntax and basic constructs.
- **Learn Rust With Entirely Too Many Linked Lists:** in-depth exploration of Rust's memory management rules, through implementing a few different types of list structures.

Please see the [Little Book of Rust Books](#) for even more Rust books.

Bölüm 70

Emekler

The material here builds on top of the many great sources of Rust documentation. See the page on [other resources](#) for a full list of useful resources.

The material of Comprehensive Rust is licensed under the terms of the Apache 2.0 license, please see [LICENSE](#) for details.

Rust by Example

Some examples and exercises have been copied and adapted from [Rust by Example](#). Please see the `third_party/rust-by-example/` directory for details, including the license terms.

Rust on Exercism

Some exercises have been copied and adapted from [Rust on Exercism](#). Please see the `third_party/rust-on-exercism/` directory for details, including the license terms.

CXX

The [Interoperability with C++](#) section uses an image from [CXX](#). Please see the `third_party/cxx/` directory for details, including the license terms.